

VBR 系列 VBR SERIES



- ◇ 輕巧設計，配置快速接頭，節約成本
Compact design, configure with fast connector, lower the cost
- ◇ 壓力開關型運用磁性感應原理設計，發生器整體美觀精緻，重量輕巧，使用更方便。
The pressure switch uses magnetic induction principle, generator is compact, light, easier to use
- ◇ 最佳供氣壓力 4.5-5bar
Optimum supply pressure 4.5 - 5 bar

產品規格 SPECIFICATION

型號 Model	VBR-05HS VBR-05HSCK*	VBR-10HS VBR-10HSCK*	VBR-15 HS VBR-15HSCK*	VBR-20 HS	VBR-25 HS	VBR-30 HS
供氣壓力 Supply pressure	2~6 bar					
環境溫度 Working temperature	0~60°C					
真空流量(L/min) Quantity of sucked air	8	32	65	110	165	220
最大真空度(-kap) Max. vacuum level	88	93	93	93	92	92
空氣消耗(L/min) Air consumption	12	44	100	180	265	385

*CK-帶可調磁感應開關,開關規格如下表 *CK-with vacuum switching, specification as below :

使用流體 Fluid	空氣(真空) Air(vacuum)	反覆精度 Repeatability	±5 kpa
壓力可調範圍 Pressure range	-40~-60 kpa	使用電壓 Supply	DC24 以下
初期壓力設定 Initial pressure set	-50 kpa	負荷電流 Load current	Max.40 mA
應差 Differential	13±5 kpa	環境溫度 Working temperature	0-60°C

外觀尺寸 OVERALL DIMENSION

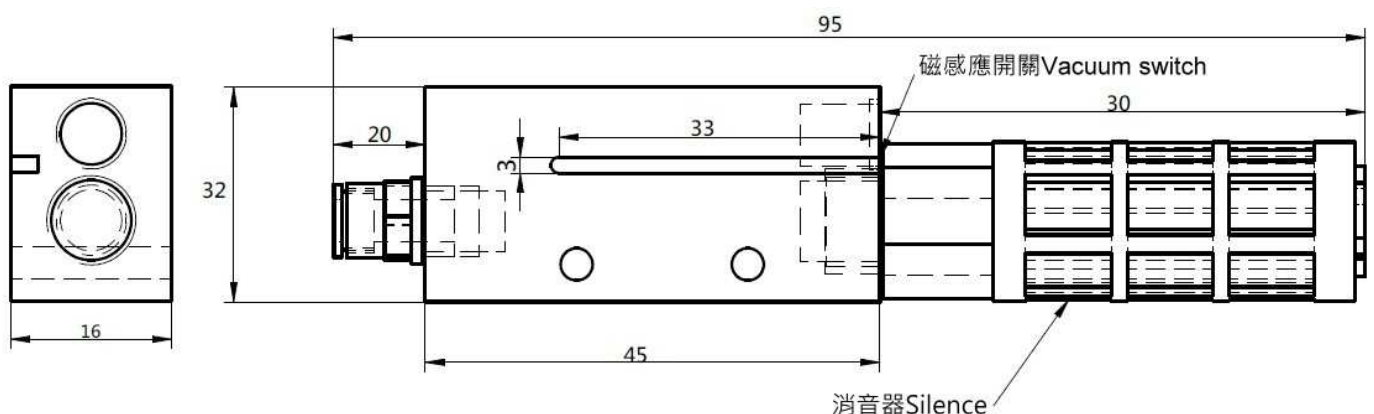

VBR-10

單級真空發生器 SINGLE-STAGE VACUUM GENERATORS

外觀尺寸 OVERALL DIMENSION

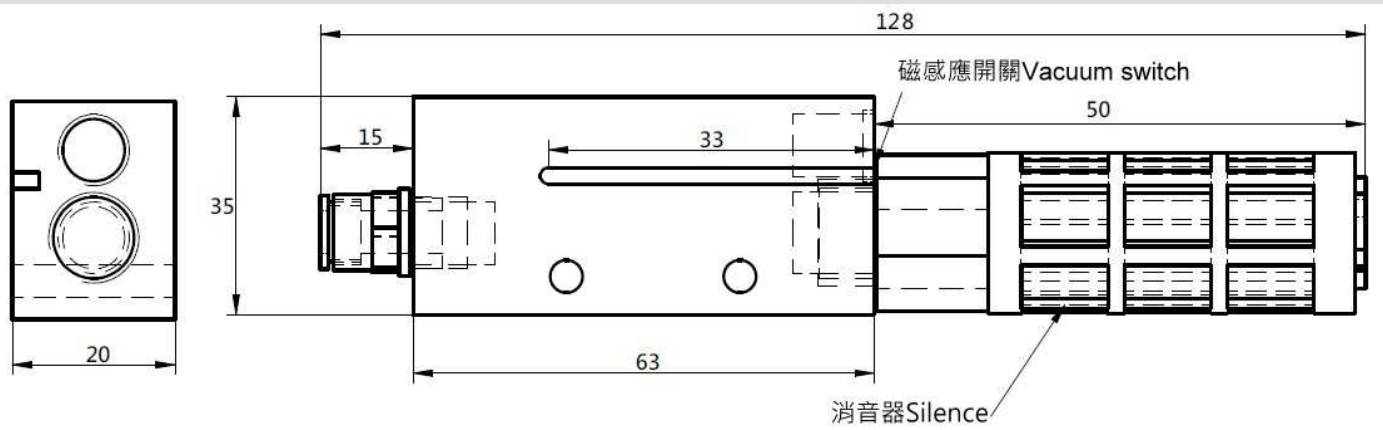

VBR-15

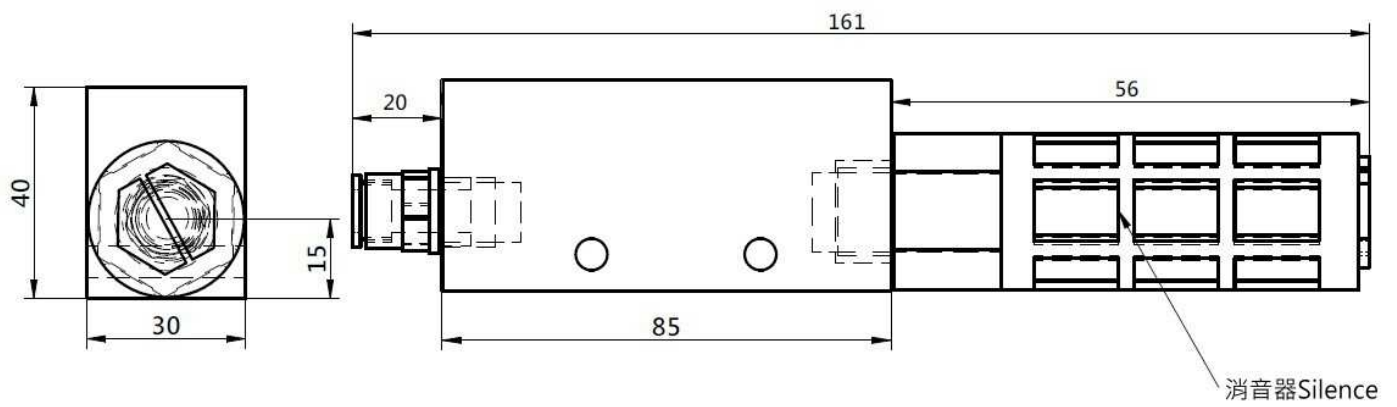

VBR-20