

Series U

Cylinders to ISO 6432 standard.....	page 1.3
Accessories: fixings	page 1.6
Accessories: piston rod locking unit series WBZ	page 1.7
Accessories: guide units series WUG.....	page 1.8

Series P

Round cylinders	page 1.12
Accessories: fixings	page 1.14

Series UP

Stainless steel round cylinders with techno-polymer end caps (to ISO 6432 standard for $\varnothing 16 \div 25$).....	page 1.15
Accessories: AISI 304 stainless steel fixings for round cylinders to ISO 6432 standard $\varnothing 16 \div 25$	page 1.17
Accessories: AISI 304 stainless steel fixings for round cylinders $\varnothing 32 \div 50$	page 1.19

Series X

“Clean profile” cylinders to ISO 15552 standard	page 1.21
Accessories: cover strips and fixing brackets	page 1.24
Accessories: fixings	page 1.28
Accessories: piston rod locking unit for cylinder series WBZ	page 1.33
Accessories: guide unit for cylinder series WUG	page 1.34

Series CPUI

Tie rods cylinders to ISO 15552 standard	page 1.25
Accessories: cover strips and fixing brackets	page 1.28
Accessories: piston rod locking unit for cylinder series WBZ	page 1.33
Accessories: guide unit for cylinder series WUG	page 1.34

Series CPA

Twin rod cylinders	page 1.38
Accessories: fixings	page 1.40

Series CX

Cylinders to AFNOR NF E49-001 (ex CNOMO) standard	page 1.41
Accessories: fixings	page 1.44

Series CPU

Cylinders to ex CETOP RP 43 P standard.....	page 1.47
Accessories: fixings	page 1.49

Series BU

Compact cylinders to AFNOR NF E49-004-1 and NF E49-004-2 standards.....	page 1.51
Accessories: fixings	page 1.57

Series B

Compact cylinders	page 1.59
Accessories: fixings	page 1.66

Series BG

Compact guided cylinders.....	page 1.67
Accessories: fixings	page 1.68

Series HB

Screwed-head cylinders	page 1.69
------------------------------	-----------

Series Z

Rodless cylinders.....	page 1.75
Accessories: fixings	page 1.79

Series HS

Hydraulic speed regulators	page 1.81
Accessories: fixings	page 1.86

Series WR

Rotary cylinders	page 1.88
------------------------	-----------

Series F

Cylinders piston rod attachments.....	page 1.90
---------------------------------------	-----------

Series FM

Magnetic sensors for cylinders series FM100 - FM101 - FM157 - FM158.....	page 1.93
--	-----------

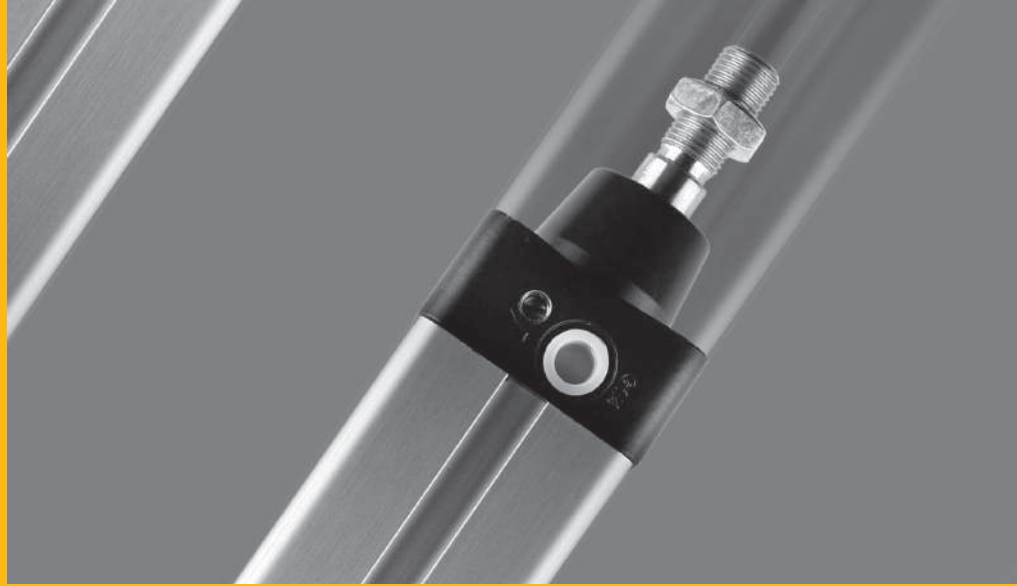

Waircom cylinders: overview

Waircom offers an extensive range of cylinders that can satisfy the most disparate demands and industrial applications. We are able to propose linear (with or without piston rod), guided, compact, non-rotating and rotary actuators, that comply with the most common international standards or with our own designs and that point at the optimisation of the quality/price rate, without neglecting the always present care to the continuous innovation.

All the series foresee, when not already included in the initial designs of the cylinders, even the application of convenient accessories or magnetic sensors that allow an even wider possibility of exploitation. As usual all these can work thanks to a production driven by a management of the quality system that complies all the demands included in the reference standard UNI EN ISO 9001:2000.

DESCRIPTION

Cylinders series "U" comply with ISO 6432 standard. The basic version is available for every diameter, while the rear axial feed, the magnetic piston and the adjustable cushions versions are produced from Ø 16 to Ø 25.

TECHNICAL DATA

Operating pressure	1 ÷ 10 bar
Working temperature	0 ÷ +80 °C (-20 °C with dry air) 0 ÷ +150 °C with seals for high temperatures (-10 °C with dry air)
Fluid	Filtered, unlubricated or continuous lubricated compressed air
Versions	Double acting; Single acting front spring; Single acting rear spring; Through rod; Flat rear cap (rear axial feed).
Bore	Ø 8, 10, 12, 16, 20, 25
Port size	Ø 8 ÷ 16 = M5 Ø 20 - 25 = G1/8
Standard strokes (mm)	10, 15, 20, 25, 30, 40, 50, 60, 70, 80, 90, 100, 120, 125, 140, 150, 160, 180, 200, 250, 300, 350, 400, 500
Decelerators length	Ø 16 20 25 mm 17 18 18.5
Maximum strokes (mm)	Ø 8 - 10 = 150; Ø 12 - 16 = 250; Ø 20 - 25 = 1000
Max. strokes single acting (mm)	Ø 8 ÷ 12 = 20; Ø 16 ÷ 25 = 50

MATERIALS

End caps	Anodized aluminium alloy
Cylinder barrel	Extruded tube, AISI 304 stainless steel
Barrel-end cover fixing type	Irreversible calking with dual-seal system, mechanical and pneumatic
Piston rod	AISI 303 rolled stainless steel
Rod and end cap nuts	Steel Stainless steel (supplied upon request)
Decelerators ogives	Brass
Piston rod bearing	Self-lubricating sintered bronze
Piston	Aluminium alloy with acetal resin piston bearing (supplied with and without magnet)
Piston seals	NBR rubber - Viton®
Springs	Springs steel

ORDER KEY

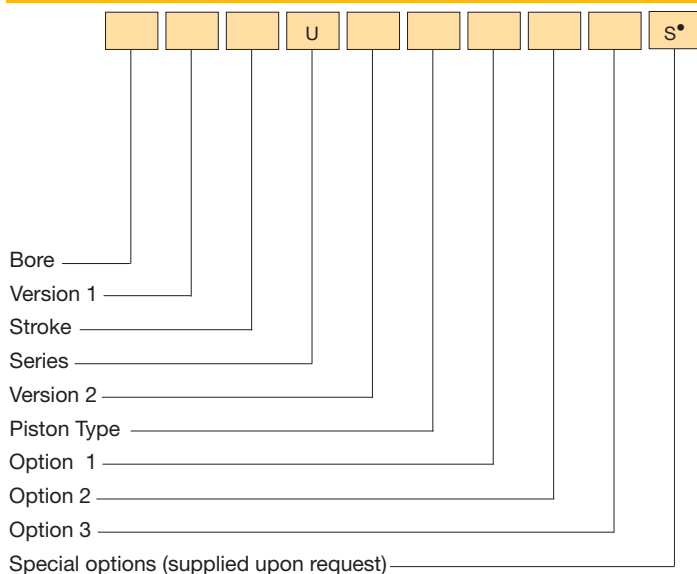

P.S.: *Magnetic sensors* FM100 - FM157 (see chapter magnetic sensors from page. 1.93)
• See technical data on page 0.12

ORDER EXAMPLES

Basic cylinder Ø16, 50 mm stroke, double acting, non-magnetic piston type 16/50 UDC

Basic cylinder Ø20, 50 mm stroke, double acting, magnetic piston type, cushioned 20/50 UDEX



SPRING THEORETICAL TRACTIVE FORCE

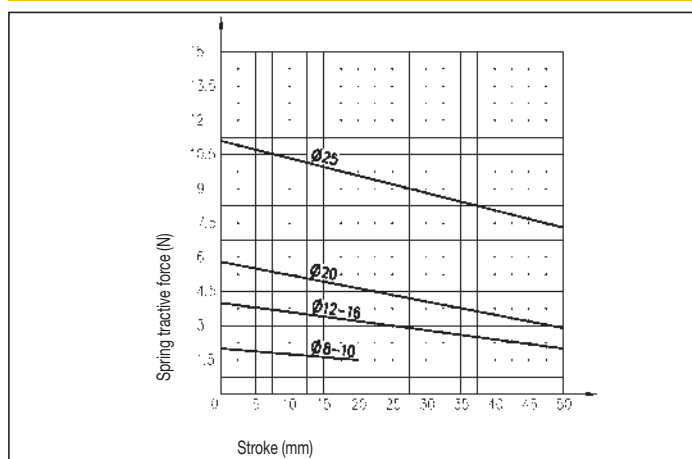

VERSION 1

/ Basic cylinder R Through rod
H Flat rear cup (rear axial feed)

VERSION 2

D Double acting Y Single acting rear spring*
S Single acting front spring

PISTON TYPE

C Non-magnetic E Magnetic

OPTION 1

X Cushioned**

OPTION 2

Z Fit for piston rod locking unit*** A With non-rotating hexagonal piston rod***

OPTION 3

2 Seals for high temperatures****

* Dimensions "XC" for version "YE" is increased of 10 mm

** Supplied from Ø 16 to Ø 25

*** Supplied for Ø 20 and Ø 25

**** Supplied only with non-magnetic piston type and standard piston rod

Cylinder Ø25, through rod, 100 mm stroke, double acting, magnetic piston type, cushioned 25R100 UDEX

Basic cylinder Ø25, 40 mm stroke, single acting rear spring, non-magnetic piston type, seals for high temperatures 25/40 UYC2

1

U BASIC CYLINDER

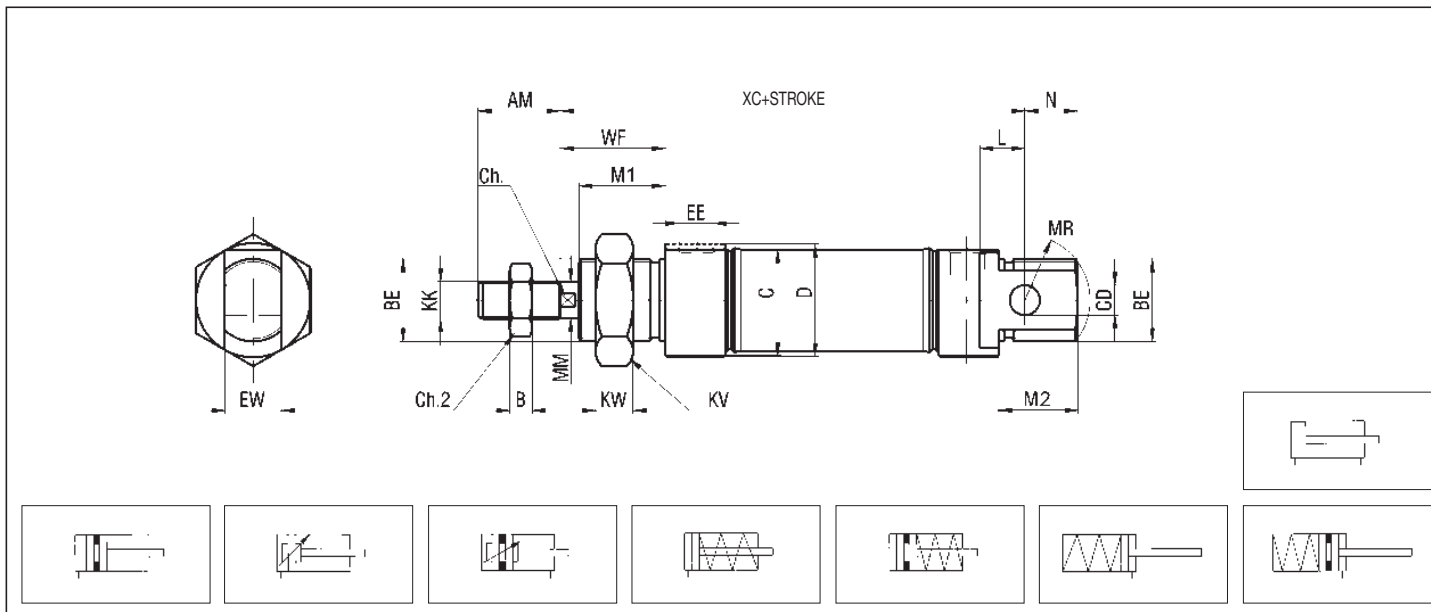

P.S.: End cap nut and rod nut supplied as standard

DIMENSIONS AND WEIGHTS BASIC CYLINDER

Ø	AM*	B	BE*	C	CD* H9	Ch*	Ch2	D*	EE*	ES	EW* d13	KK	KV	KW*	L*	LB	M1	M2	MM	MR*	N	WB	WF*	XC*	WEIGHT (g)	INCR. (g) x 10 mm
8	12	3	M12x1,25	15	4	-	7	16	M5	-	8	M4	19	6	6	60	14	12	4	9	8	-	16	64	28,3	2
10	12	3	M12x1,25	15	4	-	7	16	M5	-	8	M4	19	6	6	60	14	12	4	9	8	-	16	64	29,2	2,3
12	16	4	M16x1,5	18	6	5	10	19	M5	-	12	M6	24	8	9	70	19	19	6	12	12	-	22	75	55,3	3,7
16	16	4	M16x1,5	18	6	5	10	21	M5	-	12	M6	24	8	9	77	18	18	6	12	12	-	22	82	63	4,2
20	20	5	M22x1,5	25	8	7	13	26	G 1/8	8	16	M8	30	10	12	91	19	20	8	15	13	71	24	95	138	9,1
25	22	6	M22x1,5	28,5	8	9	17	30	G 1/8	10	16	M10x1,25	30	10	12	100	23	22	10	18	15	73	28	104	188,5	12,5

* STANDARD DIMENSIONS

▲ Dimension "XC" for version "YE" is increased of 10 mm

THROUGH ROD

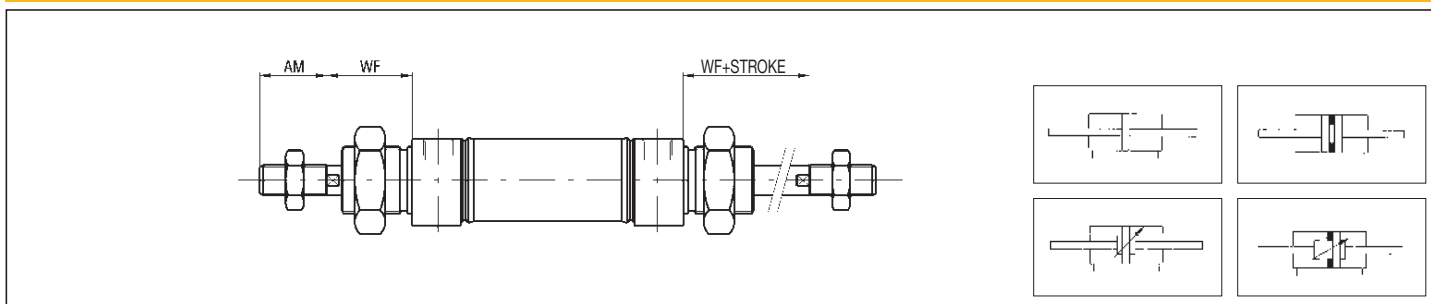

P.S.: End cap nuts and rod nuts supplied as standard

FLAT END CAP (REAR AXIAL FEED NOT INDICATED IN THE ISO 6432 STANDARD)

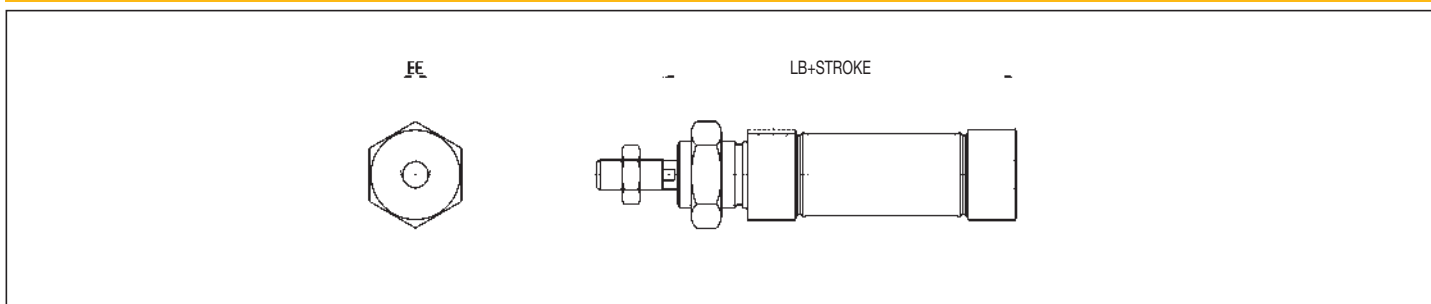

P.S.: End cap nut and rod nut supplied as standard

NON-ROTATING HEXAGON PISTON ROD

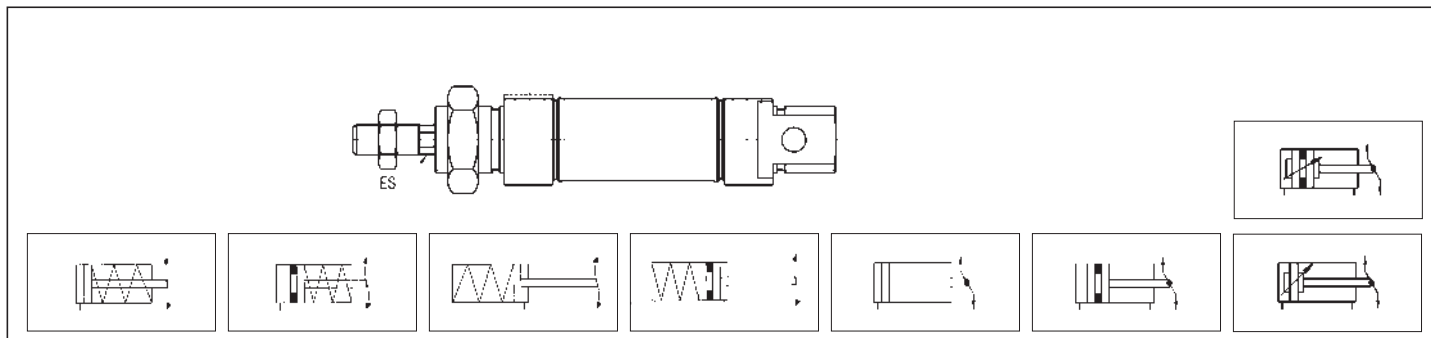

P.S.: End cap nut and rod nut supplied as standard

FIT FOR PISTON ROD LOCKING UNIT

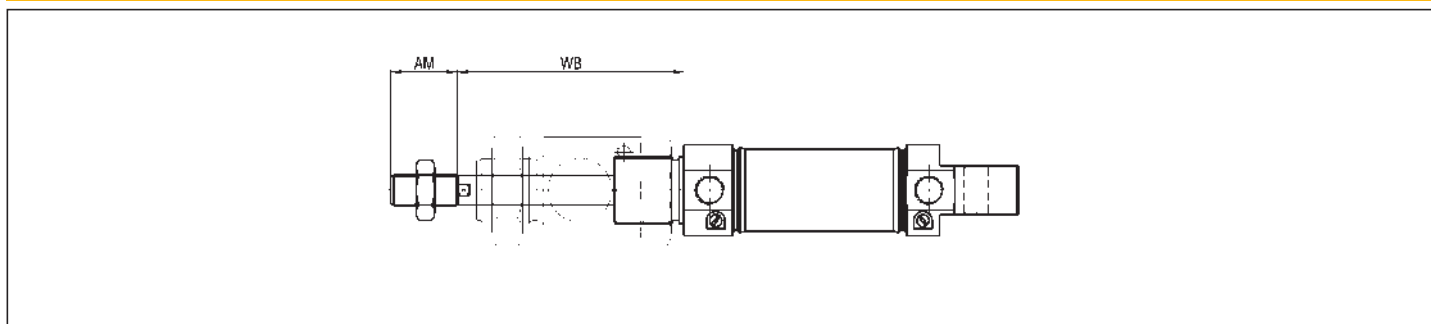

P.S.: End cap nut and rod nut supplied as standard

END CAP NUT - STEEL - UDT Ø

Ø	DI	CH	S	WEIGHT (g)
8-10	M12x1,25	19	6	7
12-16	M16x1,5	24	8	16
20-25	M22x1,5	30	10	25

AISI 304 STAINLESS STEEL
SUPPLIED UPON REQUEST
(SEE PAGE 1.17)

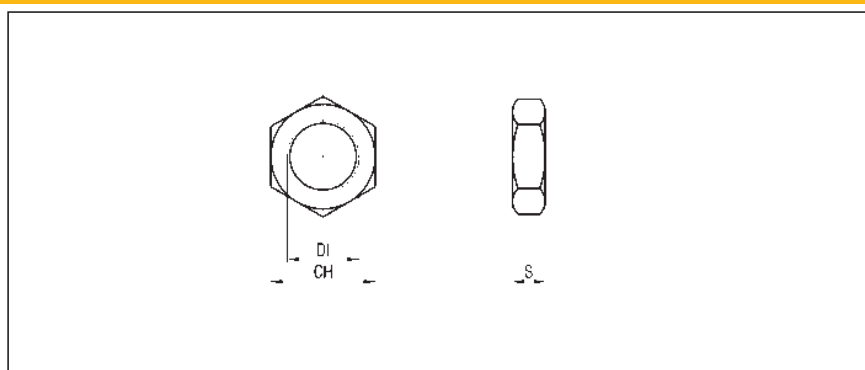

1

FLANGE - STEEL - UF Ø

Ø	FB H13	LW	S	TF JS13	UF	UR	WEIGHT (g)
8-10	4,5	13	3	30	39	19	5
12-16	5,5	18	4	40	54	30	10
20	6,6	19	5	50	64	36	20
25	6,6	23	5	50	64	36	20

AISI 304 STAINLESS STEEL SUPPLIED UPON REQUEST
(SEE PAGE 1.17)

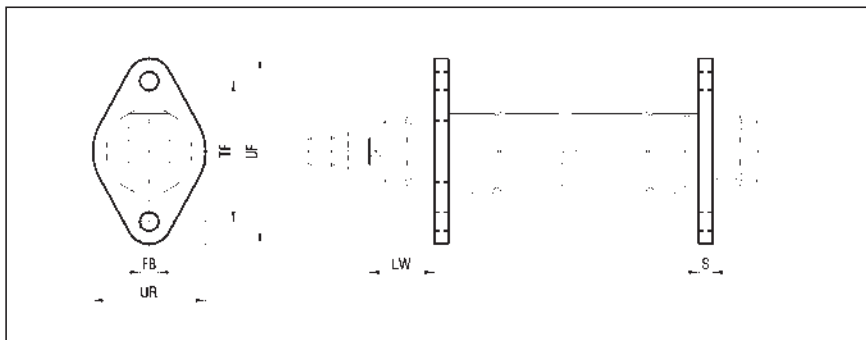

FOOT - STEEL - UP Ø

Ø	AB H13	AU	LA	LB	LC	NH	R
8-10	4,5	9,5	14	64	28	16	9,5
12-16	5,5	12	19	74-81	28-35	20	13
20	6,6	13	21,5	91	45,5	25	18
25	6,6	13	21,5	95	49,5	25	18

Ø	S	TR JS13	US	XS	XT	WEIGHT (g)
8-10	1,5	25	34	24	6,5	10
12-16	2	32	46	32	10	25
20	2,5	40	54	35	11	40
25	2,5	40	54	39	15	40

AISI 304 STAINLESS STEEL SUPPLIED UPON REQUEST
(SEE PAGE 1.17)

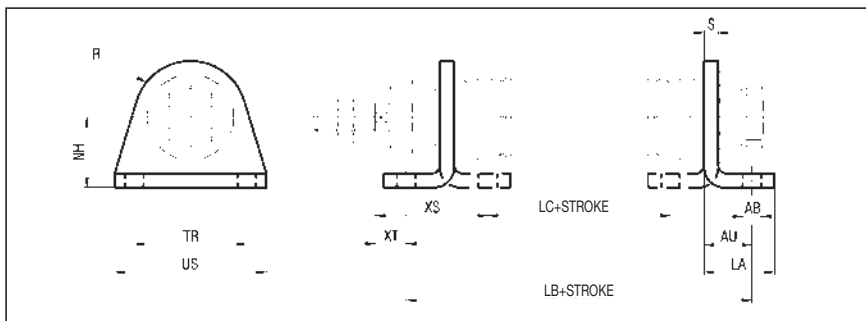

REAR HINGE - STEEL - USC Ø

Ø	CD f8	D H13	H	LA	LB JS13	LC E9	LD
8-10	4	4,5	24	20	12,5	8,1	3,75
12	6	5,5	27	25	15	12,1	5
16	6	5,5	27	25	15	12,1	5
20	8	6,6	30	32	20	16,1	6
25	8	6,6	30	32	20	16,1	6

Ø	LE	LX	R	S	WEIGHT (g)
8-10	17	62,75	5	2,5	20
12	25	73	7	3	36
16	25	80	7	3	36
20	29,5	91	10	4	78
25	29,5	100	10	4	78

AISI 304 STAINLESS STEEL SUPPLIED UPON REQUEST
(SEE PAGE 1.17)

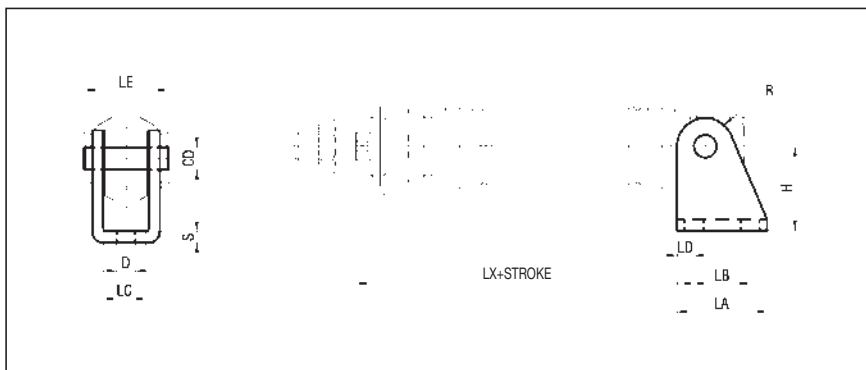

FLOATING HINGE - STEEL - UCT Ø

Ø	LA	LB	TD	TL	TM	UW	WEIGHT (g)
8-10	13	64	4	6	26	20	17
12-16	14	76-83	6	10	38	25	35
20	20	93	6	10	46	30	45
25	24	101	6	10	46	30	45

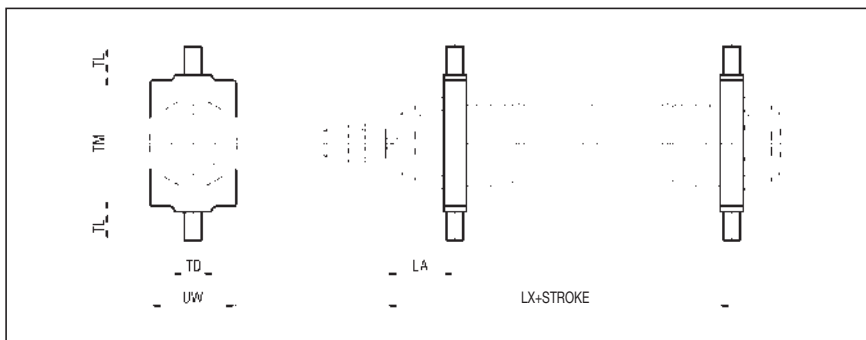

Accessories

Piston rod locking unit for cylinders to ISO 6432 standard

series WBZ

DESCRIPTION

Piston rod locking unit series "WBZ" is a mechanical device to fit on ISO 6432 cylinders (series "U" and "UP"); its function is to lock the piston rod in any position. This solution allows to lock the cylinder stroke each time that there's a pressure fall. Locking force is, in any case, higher than the force given off by the cylinder fed at 10 bar. It has static operation (cylinder piston rod not moving); it's necessary to preliminary stop the cylinder piston rod before proceeding with mechanical locking. Piston rod locking unit series "WBZ" must not be considered as a safety device.



1

TECNICAL DATA

Operating pressure	3 ÷ 6 bar with cylinder feed pressure 0 ÷ 10 bar		
Working temperature	0 ÷ +80 °C (-5 °C with dry air)		
Fluid	Filtered, unlubricated or continuous lubricated compressed air		
Size	20, 25		
Port size	20 - 25 = M5		
Locking Type	Mechanical - Only axial (bi-directional)		
Release	Through pneumatic control		
Condition in absence of pressure	Locked		
Locking force with static load	Size	20	25
	N	490	490

MATERIALS

Body	Anodized aluminium alloy
Blades	Brass
Pistons	Acetal resin
Seals	NBR rubber
Springs	Steel

ORDER KEY

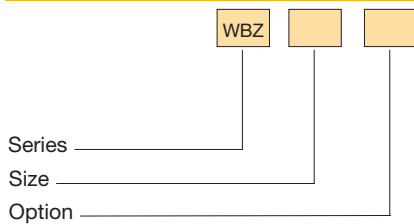

OPTION

G Fit for assembly with guide units series "WUG"*

* Feeding is rotated of 90°

ORDER EXAMPLES

Piston rod locking unit, size 20
WBZ20

Piston rod locking unit, size 25 + cylinder series "U" Ø25, fit for piston rod locking unit, 150 mm stroke, double acting, non-magnetic piston type, ASSEMBLED:
WBZ25 + 25/150 UDCZ + M/WBZ

ASSEMBLY

"WBZ" + cylinders series "U" or "UP", "Z" version M/WBZ

SPARE PARTS

BLADES KIT	Size /PM/WBZ
PISTON KIT	Size /SG/WBZ

TECHNICAL INFORMATION

"WBZ" operation is based on the action of two opposed blades. When these blades are opened up by suitably loaded springs, they oppose the sliding movement of the piston rod passing through them. It is advisable to balance the pressure in the cylinder chambers during piston rod locking phase in order to increase its working life with a 5/3 pressure centre valve (see the schemes here below).

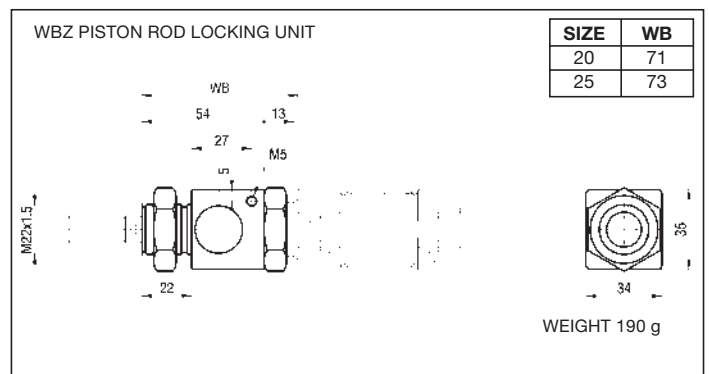
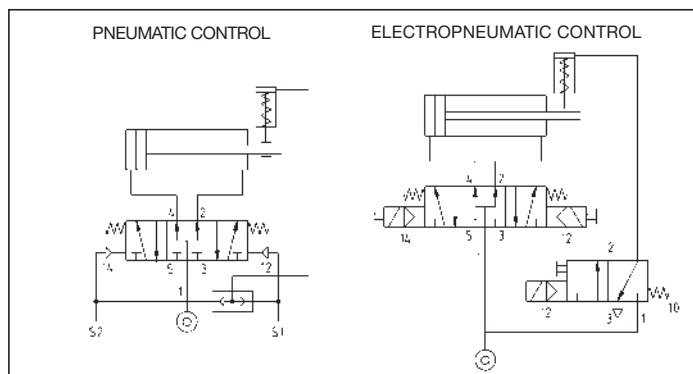

DESCRIPTION

Guide units series "WUG" for cylinders to ISO 6432 standard act as devices against rotation of the piston rod in the presence of torques and they are used to carry out multi-axis systems where high movement precision is required.

Guide units are available in single and double version, and are supplied with self-lubricating bushings (for low speeds or heavy loads), or with recirculating ball bearing sleeves (for high speeds).

P.S.: Cylinders series "U" ($\varnothing 12 \div 25$) and "UP" ($\varnothing 16 \div 25$) in the magnetic version, assembled with these guide units, can accept exclusively magnetic sensors type FM157 (see from page 1.97).

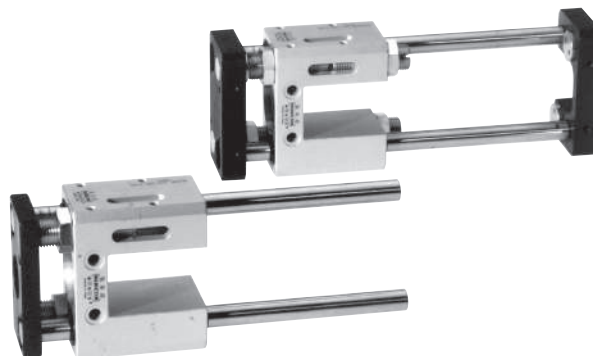

TECHNICAL DATA

Size	12 - 16, 20 - 25
Standard strokes (mm)	50, 100, 150, 200, 250, 300, 350, 400, 450, 500
Versions	Single unit Double unit

MATERIALS

Body	Anodized aluminium alloy
Self-aligning radial joint	Steel
Adjustable mechanical stop as standard	Brass
End flanges	Single unit: galvanized steel Double unit: anodized aluminium alloy
Guide bars	C45 chromium-plated steel (sliding type on bushings) Hardened steel (sliding type with sleeves)
Bushings	Self-lubricating sintered bronze with wiper ring
Sleeves	Recirculating ball bearings with wiper ring
Clamp	Brass

ORDER KEY

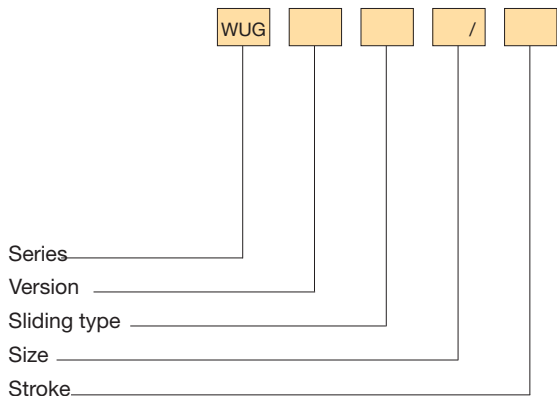

VERSION

Single unit **D** Double unit

SLIDING TYPE

B On bushings **M** With sleeves*

* Supplied only with size 20 - 25

ORDER EXAMPLES

Single guide unit, size 20 - 25, 150 mm stroke, with sleeves + cylinder series "UP" $\varnothing 25$, 150 mm stroke, double acting, magnetic piston type, ASSEMBLED

WUGM 20 - 25/150 + 25/150 UPDE + M/WUG

Single guide unit, size 12 - 16, 100 mm stroke, on bushings
WUGB 12 - 16/100

Double guide unit, size 20 - 25, 100 mm stroke, with sleeves
WUGDM 20 - 25/100

ASSEMBLY

"WUG" + cylinders series "U" or "UP" ($\varnothing 16 \div 25$) **M/WUG**

TECHNICAL INFORMATION

WUG SINGLE GUIDE UNIT

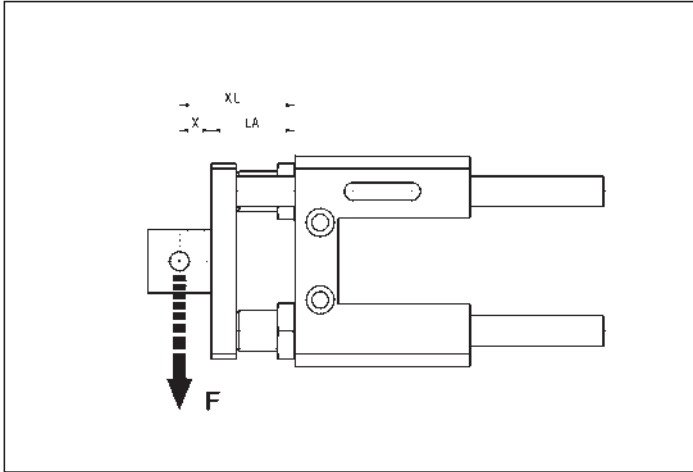

WUGD DOUBLE GUIDE UNIT

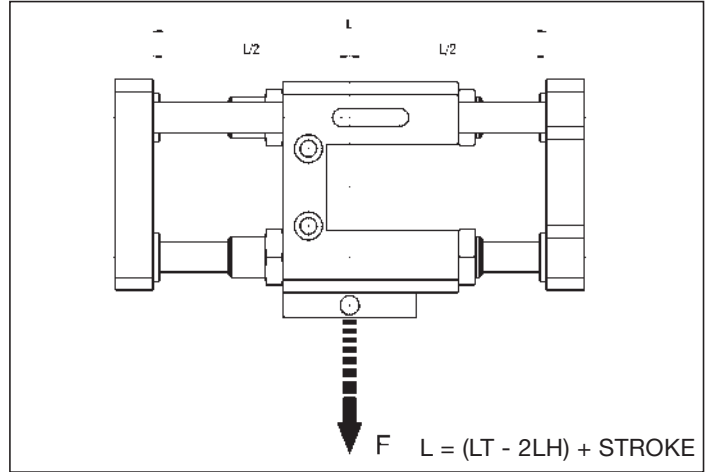

MAXIMUM PERMISSIBLE LOAD-WUG VERSION B

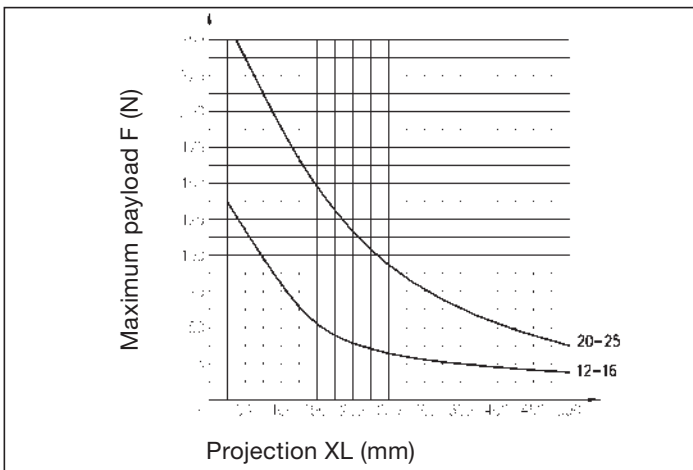

MAXIMUM PERMISSIBLE LOAD-WUGD VERSION B

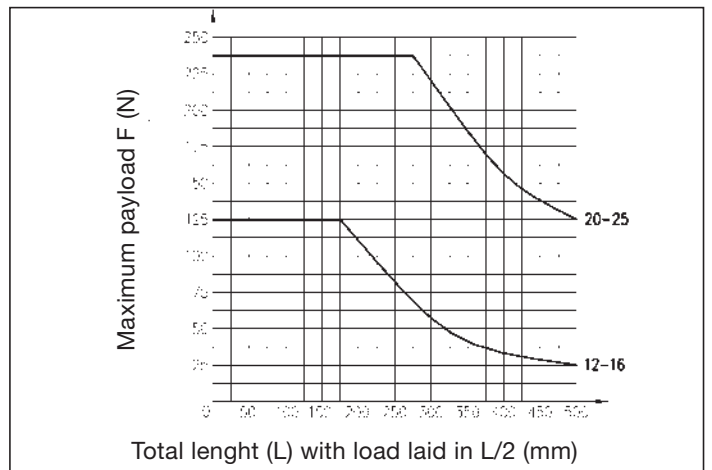

MAXIMUM PERMISSIBLE LOAD-WUG VERSION M

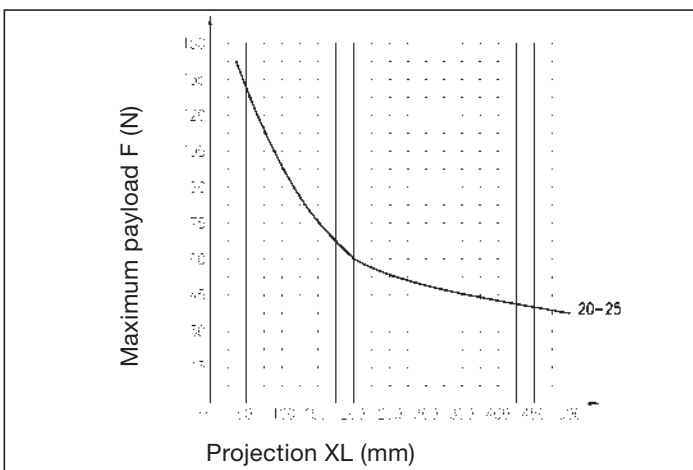

MAXIMUM PERMISSIBLE LOAD-WUGD VERSION M

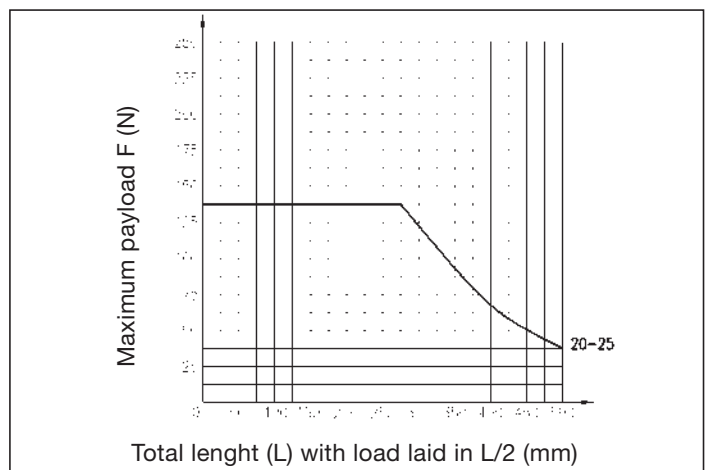

WUG SINGLE GUIDE UNIT

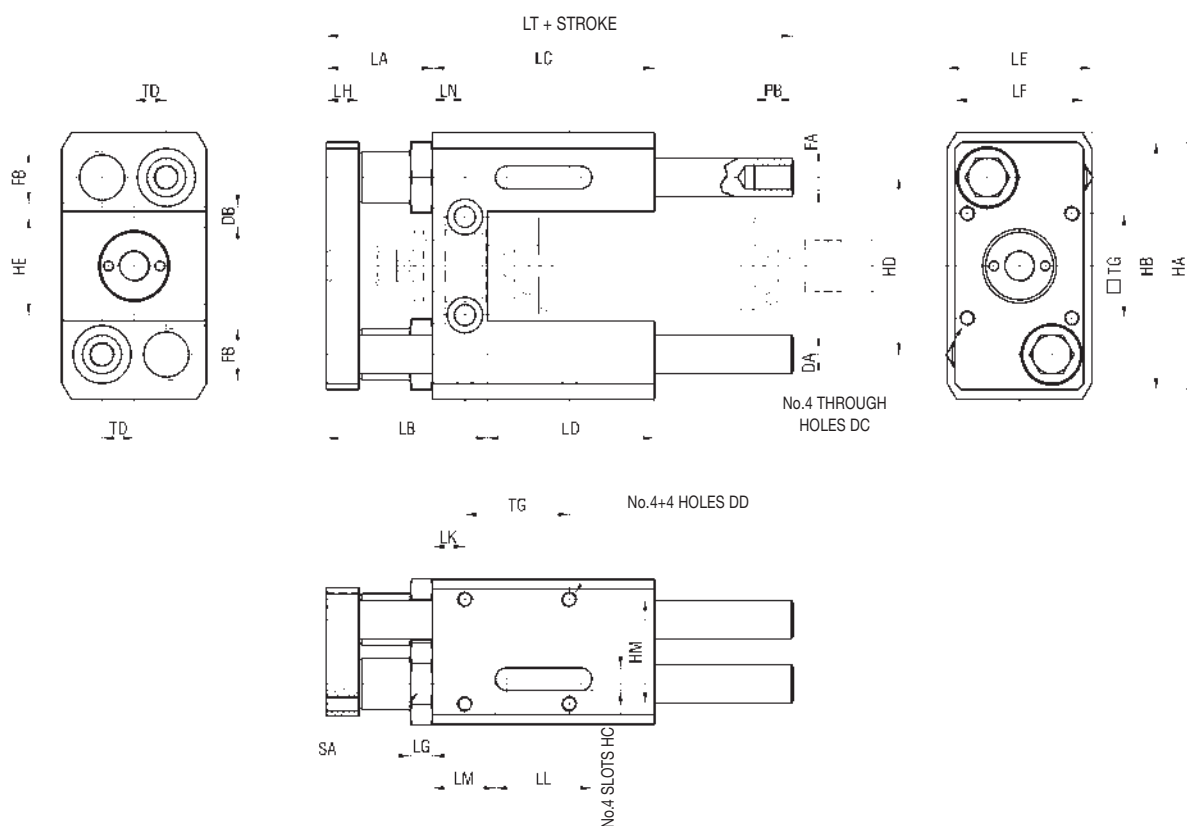

DIMENSIONS AND WEIGHTS

SIZE	DA	DB	DC	DD	FA		FB	HA	HB	HC	HD	HE	HM	LA	LB	LC	LD	LE	LF	LG	LH
12-16	10	5,2	M4	M5	M6		M12x1,25	65	60	6	47	24	32,5	25	28	60	47	40	35	7	10
20	B12 M10	6,5	M4	M5	BM8 MM6		M16x1,5	83	77	7	55	30,5	32,5	27	44	69	52	45	40	7	10
25	B12 M10	6,5	M4	M5	BM8 MM6		M16x1,5	83	77	7	55	30,5	32,5	32	50	69	52	45	40	7	10

SIZE	LK	LL	LM	LN	LT	PB	SA	TD	TG	WEIGHT (g)		INCREM. (g) every 10 mm	
12-16	19	16	22	6,5	100	12	Ch.14	8,5	22	690		12	
20	10	30	19,5	10	115	12	Ch.21	10	32,5	B890 M830	B17 M12		
25	10	30	19,5	10	115	12	Ch.21	10	32,5	B890 M830	B17 M12		

B - Bushings

M - Sleeves

WUGD DOUBLE GUIDE UNIT

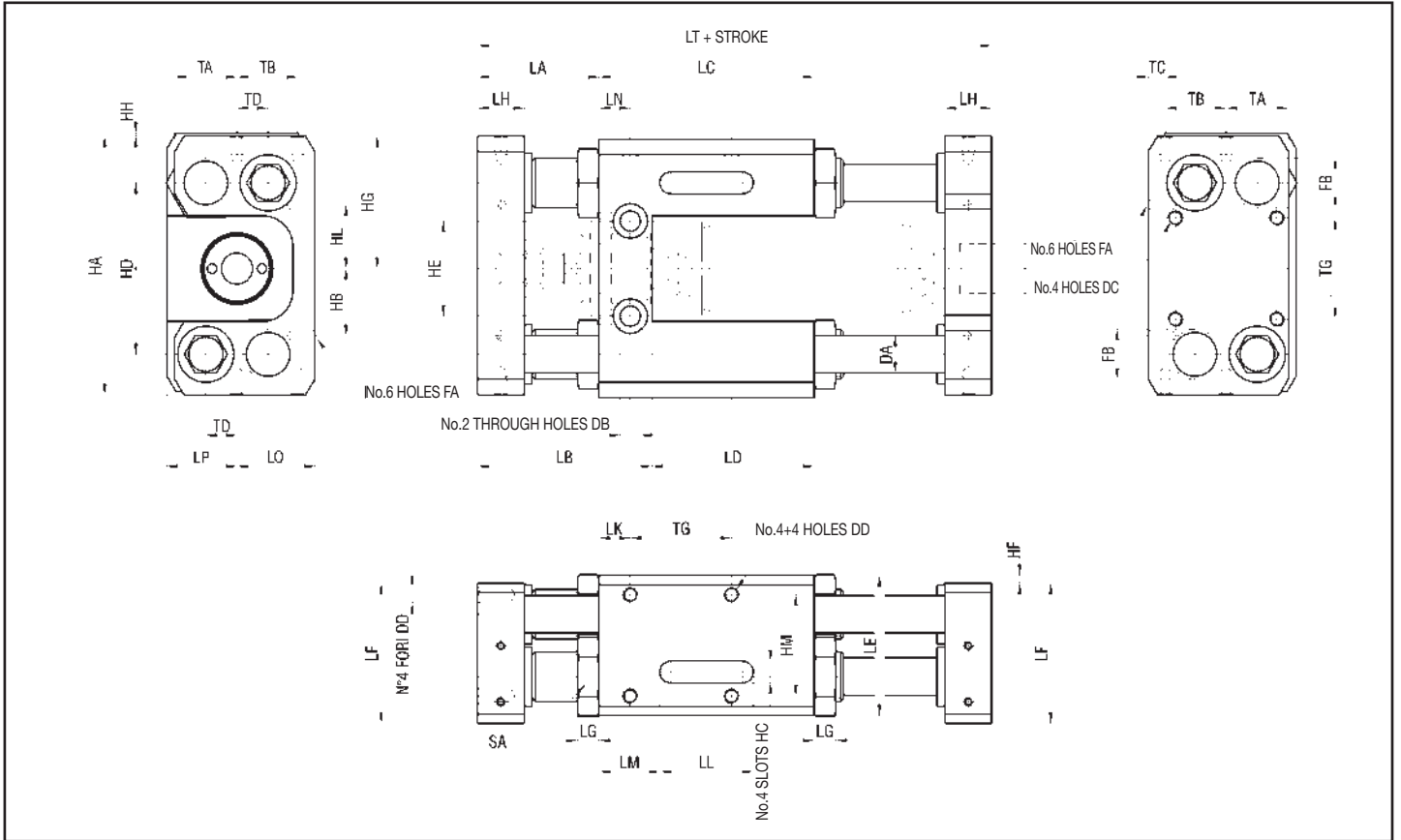

DIMENSIONS AND WEIGHTS

SIZE	DA	DB	DC	DD	FA	FB	HA	HB	HC	HD	HE	HF	HG	HH	HL	HM	LA	LB	LC	LD	LE
12-16	10	5,2	M4	M5	M4	M12x1,25	65	18	6	47	24	1,3	30,5	1	18	32,5	30	43	60	47	40
20	B 12 M 10	6,5	M4	M5	M4	M16x1,5	83	21,5	7	55	30,5	2,5	40,5	1	20,5	32,5	33	50	69	52	45
25	B 12 M 10	6,5	M4	M5	M4	M16x1,5	83	21,5	7	55	30,5	2,5	40,5	1	20,5	32,5	39	56	69	52	45

SIZE	LF	LG	LH	LK	LL	LM	LN	LO	LP	LT	SA	TA	TB	TC	TD	TG	WEIGHT (g)	INCREM. (g) every 10 mm
12-16	40	7	15	19	16	22	6,5	22,5	19	120	Ch.14	17,5	17,5	5	8,5	22	740	12
20	45	7	15	10	30	19,5	10	25	22,15	135	Ch.21	20	19,5	5,5	10	32,5	B 1170 M 1110	B 18 M 12
25	45	7	15	10	30	19,5	10	25	22,15	135	Ch.21	20	19,5	5,5	10	32,5	B 1170 M 1110	B 18 M 12

B - Bushings
M - Sleeves

CLAMP FOR DECELERATOR WUGCD SIZE

SIZE	FA	FB	L	WEIGHT (g)
12-16	M12x1,5	M8x1	35	20
20-25	M16x1,5	M8x1	40	50

CLAMP FOR MAGNETIC PROXIMITY WUGCP SIZE

SIZE	FA	FB	L	WEIGHT (g)
12-16	M12x1,5	M8x1	25	12
20-25	M16x1,5	M8x1	25	31

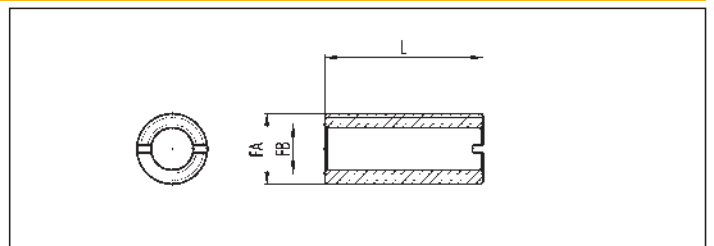

1

DESCRIPTION

Cylinders series "P" are produced with a round profile design from Ø 32 to Ø 63. They are available in the basic version, with rear axial feed, with adjustable cushions and fitted for the use with magnetic sensors.

TECHNICAL DATA

Operating pressure	1 ± 10 bar
Working temperature	0 ÷ +80 °C (-20 °C with dry air) 0 ÷ +150 °C with seals for high temperature (-10 °C with dry air)
Fluid	Filtered, unlubricated or continuous lubricated compressed air
Versions	Double acting; Single acting front spring; Single acting rear spring; Through rod; Flat rear cap (rear axial feed); Reduced flat rear cap
Bore	Ø 32, 40, 50, 63
Port size	Ø 32 = G 1/8 Ø 40 - 50 = G 1/4 Ø 63 = G 3/8
Standard strokes (mm)	10, 25, 50, 75, 80, 100, 125, 150, 160, 175, 200, 250, 300, 320, 350, 400, 450, 500
Decelerators length	Ø 32 40 50 63 mm 29 35 40 40
Max strokes (mm)	Ø 32 ÷ 63 = 1000
Max strokes single act. (mm)	Ø 32 ÷ 63 = 50

MATERIALS

End caps	Anodized aluminium alloy
Cylinder barrel	Extruded tube, AISI 304 stainless steel
Barrel-end cover fixing type	Irreversible calking with dual-seal system, mechanical and pneumatic
Piston rod	C45 chromium-plated steel AISI 303 rolled stainless steel
Rod nut and ring nut	Steel Stainless steel (supplied upon request for the ring nut)
Decelerator ogives	Anodized aluminium alloy
Piston rod bearing	Self lubricating sintered bronze
Piston	Aluminium alloy with acetel resin piston bearing (supplied with and without magnet)
Piston seals	Polyurethane - Viton®
Springs	Spring steel

ORDER KEY

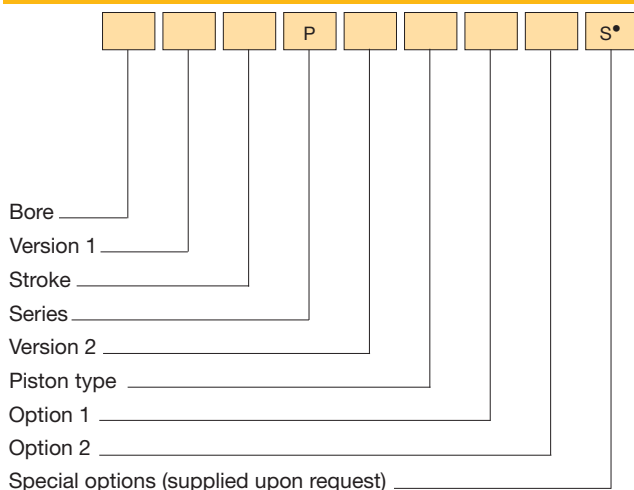

N.B.: *Magnetic sensors* FM 100 - FM157 (see chapter magnetic sensors from page 1.93)
 • See technical data on page 0.12

ORDER EXAMPLES

Basic cylinder Ø32, 50 mm stroke, double acting, non magnetic piston type 32/50 PDC

Basic cylinder Ø40, 50 mm stroke, double acting, magnetic piston type, cushioned 40/50 PDEX



SPRING THEORETICAL TRACTIVE FORCE

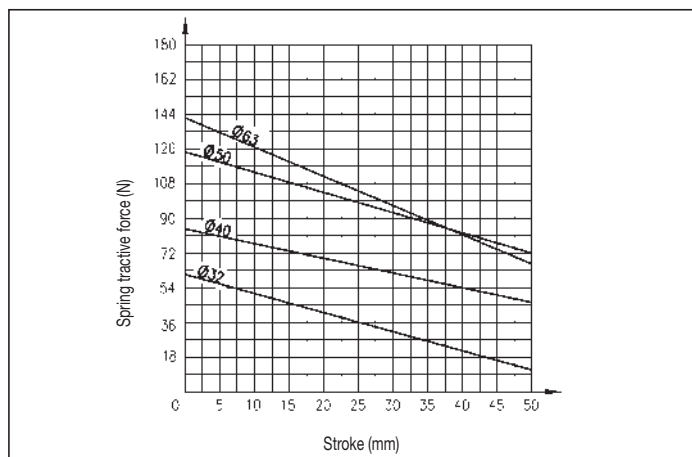

VERSION 1

/ Basic cylinder **R** Through rod
H Flat rear cap (rear axial feed) **C** Reduced flat rear cap*

VERSION 2

D Double acting **Y** Single acting rear spring**
S Single acting front spring

PISTON TYPE

C Non-magnetic **E** Magnetic

OPTION 1

X Cushioned

OPTION 2

1 Stainless steel piston rod and rod nut **3** Stainless steel piston rod and rod nut, and seals for high temperature***
2 Seals for high temperature***

* Not available in the option "X"

** Different dimensions from the versions "D" and "S"; contact the commercial office

*** Supplied only with non-magnetic piston type

Cylinder Ø50, through rod, 100 mm stroke, double acting, magnetic piston type, cushioned 50R100 PDEX

Basic cylinder Ø50, 40 mm stroke, single acting rear spring, non magnetic piston type, seals for high temperature 50/40 PYC2

P BASIC CYLINDER

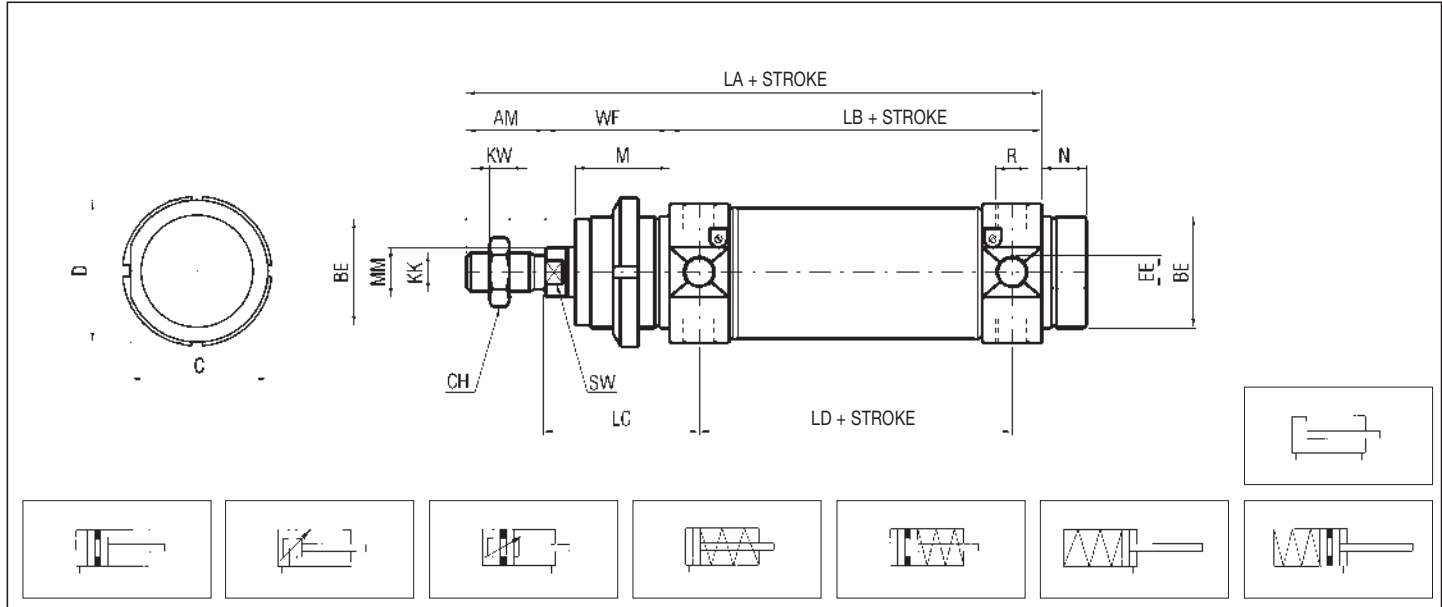

P.S.: End cap ring nut and rod nut supplied as standard

DIMENSIONS AND WEIGHTS BASIC CYLINDER

Ø	AM	BE	C	CH	D	EE	KK	KW	LA	LB	LC	LD	M	MM	N	R	SW	WF	XC	XD	WEIGHT (g)	INCR. (g) x 10 mm
32	20	M30x1,5	36,5	17	38	G1/8	M10x1,25	6	154	96	47	78	30	12	14	M8x1	10	38	134	140	386	16
40	24	M38x1,5	44	19	46	G1/4	M12x1,25	7	182	113	57	89	35	16	16	M10x1	12	45	158	163	690	26
50	32	M45x1,5	55	24	57	G1/4	M16x1,5	8	202	120	62	96	38	20	18	M12x1,5	16	50	170	176	1265	34
63	32	M45x1,5	67,5	24	70	G3/8	M16x1,5	8	206	124	63	98	38	20	18	M14x1,5	24	50	174	180	1750	50

THROUGH ROD

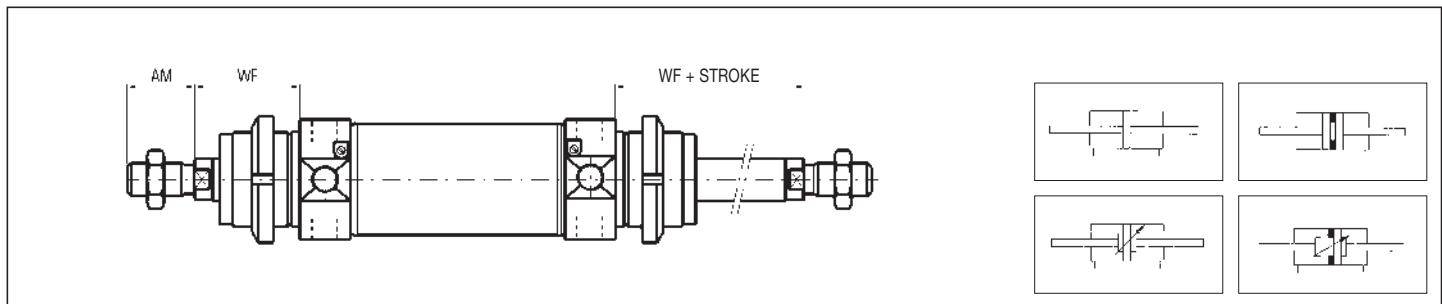

P.S.: End cap ring nuts and rod nuts supplied as standard

FLAT END CAP (REAR AXIAL FEED)

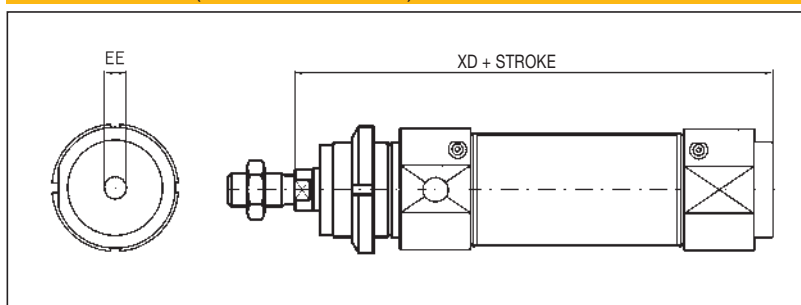

P.S.: End cap ring nut and rod nut supplied as standard

REDUCED FLAT REAR CAP

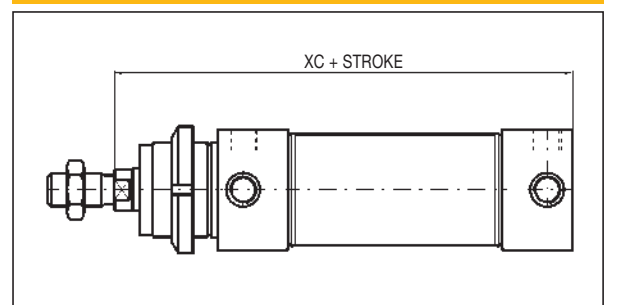

P.S.: End cap ring nut and rod nut supplied as standard

1

RING NUT - STEEL - PG Ø

Ø	d	D	S	WEIGHT (g)
32	M30x1,5	42	8	43
40	M38x1,5	50	10	80
50-63	M45x1,5	60	10	122

AISI 304 STAINLESS STEEL SUPPLIED UPON REQUEST
(SEE PAGE 1.19)

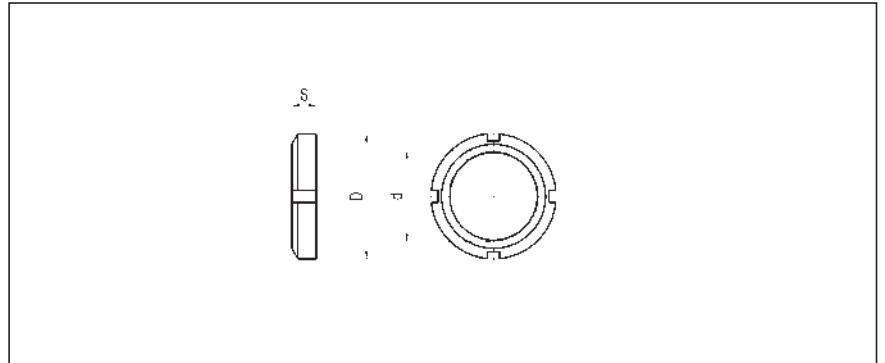

FLANGE/FOOT - STEEL - PFP Ø

Ø	AB	AU	HA	HB	HC	LA	LB	LC
32	7	14	14	49	28	21	124	76
40	9	20	18	58	30	30	153	83
50	9	20	20	70	40	30	160	92
63	9	20	20	80	50	30	164	96

Ø	NH	S	TB	TR	TS	XS	XT	WEIGHT (g)
32	28	4	14	52	66	48	24	98
40	33	5	20	60	88	60	25	183
50	40	6	20	70	90	64	30	276
63	45	6	20	76	96	64	30	395

AISI 304 STAINLESS STEEL SUPPLIED UPON REQUEST
(SEE PAGE 1.19)

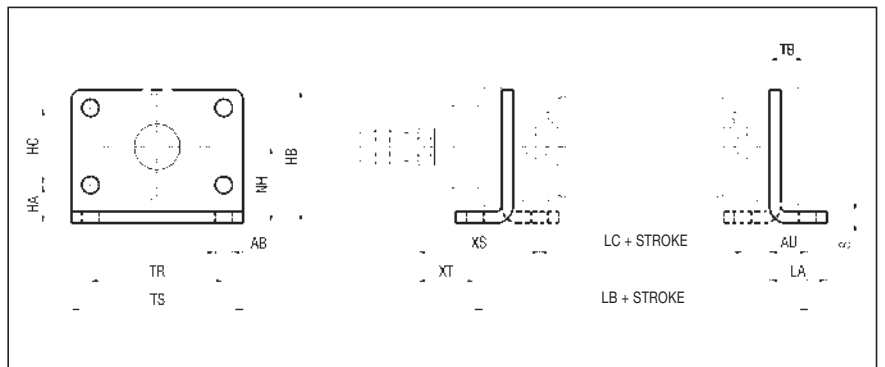

REAR HINGE - STEEL - PSC Ø

Ø	CH	E	G	H	L	LA	LB
32	13	7	20	34	125	20	46,1
40	17	9,5	27	38	146	28	56,1
50	19	10	30	44	158	36	69,1
63	19	10	34	50	161	42	82,1

Ø	LC	NA	NB	R	S	WEIGHT (g)
32	58	24	40	8	4	150
40	70	30	50	9,5	5	259
50	86	34	54	10	6	403
63	100	35	65	10	6	520

AISI 304 STAINLESS STEEL SUPPLIED UPON REQUEST
(SEE PAGE 1.19)

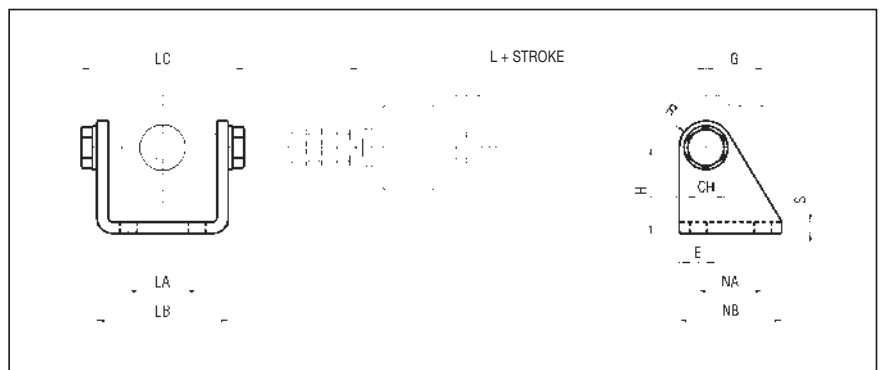

PIVOT (pair) - STEEL - PT Ø

Ø	D	H	LA	LB	CH	WEIGHT (g)
32	10	51	47	125	6	10
40	12	64	57	146	6	20
50	14	75	62	158	6	40
63	16	90	63	161	8	65

AISI 304 STAINLESS STEEL SUPPLIED UPON REQUEST
(SEE PAGE 1.19)

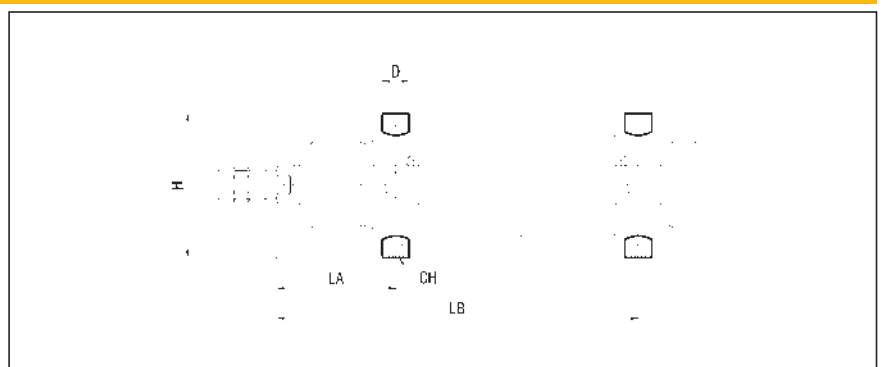

Stainless steel round cylinders with techno-polymer end caps (to ISO 6432 standard for Ø 16 ÷ 25)

series UP

DESCRIPTION

Cylinders series "UP" are born as technological efficient reply to the always new needs of different industrial fields. They are available from Ø 16 to Ø 50 among which Ø 16 ÷ 25 comply with ISO 6432 standard. These actuators set themselves as a valid yet economic alternative to cylinders completely made in stainless steel, in many "special" applications (as for example food, chemical and pharmaceutical industry...) and/or aggressive environments. In fact, the peculiar feature of this series is represented by the material used for the realization of the end caps: it's a special techno-polymer that assures adequate mechanical properties.



1

TECHNICAL DATA

Operating pressure	1 ÷ 10 bar
Working temperature	0 ÷ +70 °C (- 20 °C with dry air)
Fluid	Filtered, unlubricated or continuous lubricated compressed air
Versions	Double acting, Single acting front spring, Single acting rear spring, through rod
Bore	Ø 16, 20, 25, 32, 40, 50
Port size	Ø 16 = M5 Ø 20 ÷ 32 = G1/8 Ø 40 - 50 = G1/4
Standard strokes (mm)	10, 25, 50, 75, 80, 100, 125, 150, 160, 175, 200, 250, 300, 350, 400, 450, 500
Max strokes (mm)	Ø 16 = 250 Ø 20 ÷ 50 = 1000
Max strokes single act. (mm)	Ø 16 ÷ 50 = 50

MATERIALS

End caps	Techno-polymer
Cylinder barrel	Extruded tube, AISI 304 stainless steel
Barrel-end cover fixing type	Irreversible calking with dual-seal system, mechanical and pneumatic
Piston rod	AISI 303 rolled stainless steel
Rod, end cap and ring nuts	Stainless steel
Piston	Aluminium alloy with acetal resin piston bearing (supplied with and without magnet)
Seals	Polyurethane
Springs	Steel for springs

ORDER KEY

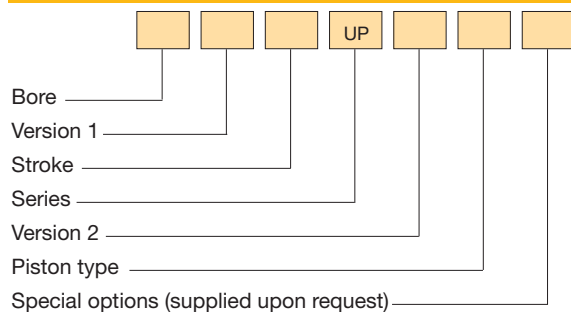

N.B.: *Magnetic sensors* FM 100 - FM157 (see chapter magnetic sensors from page 1.93)
• See technical data on page 0.12

ORDER EXAMPLES

Cylinder Ø 20, through rod, 100 mm stroke, double acting, non-magnetic piston type 20R100 UPDC

SPRING THEORETICAL TRACTIVE FORCE

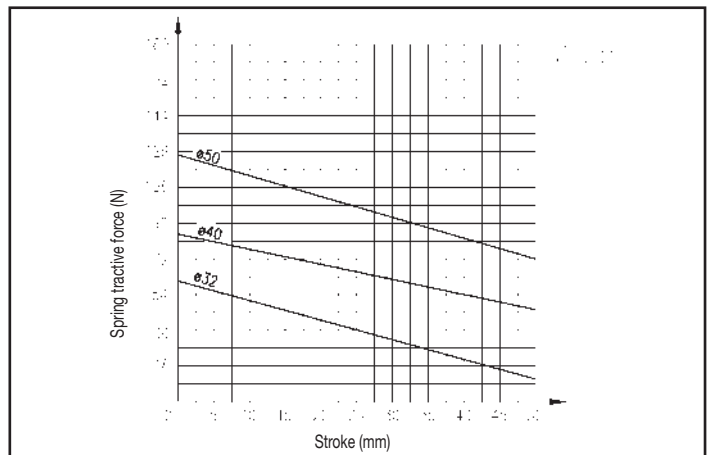
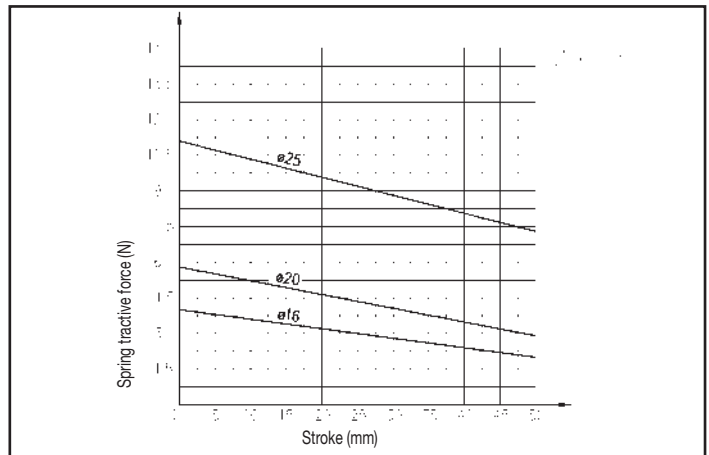

VERSION 1		
/ Basic cylinder	R	Through rod
VERSION 2		
D Double acting	Y	Single acting rear spring*
S Single acting front spring		
PISTON TYPE		
C Non-magnetic	E	Magnetic
OPTION 1		
Z	Fit for piston rod locking unit**	

* Dimension "XC" for version "YE" is increased of 10 mm for Ø 16 ÷ 25; for Ø 32 ÷ 50 contact our commercial office
** Supplied with Ø 20 and Ø 25

Basic cylinder Ø 40, 50 mm stroke, single acting front spring, non-magnetic piston type 40/50 UPSC

UP BASIC CYLINDER Ø 16 ÷ 25 TO ISO 6432 STANDARD

1

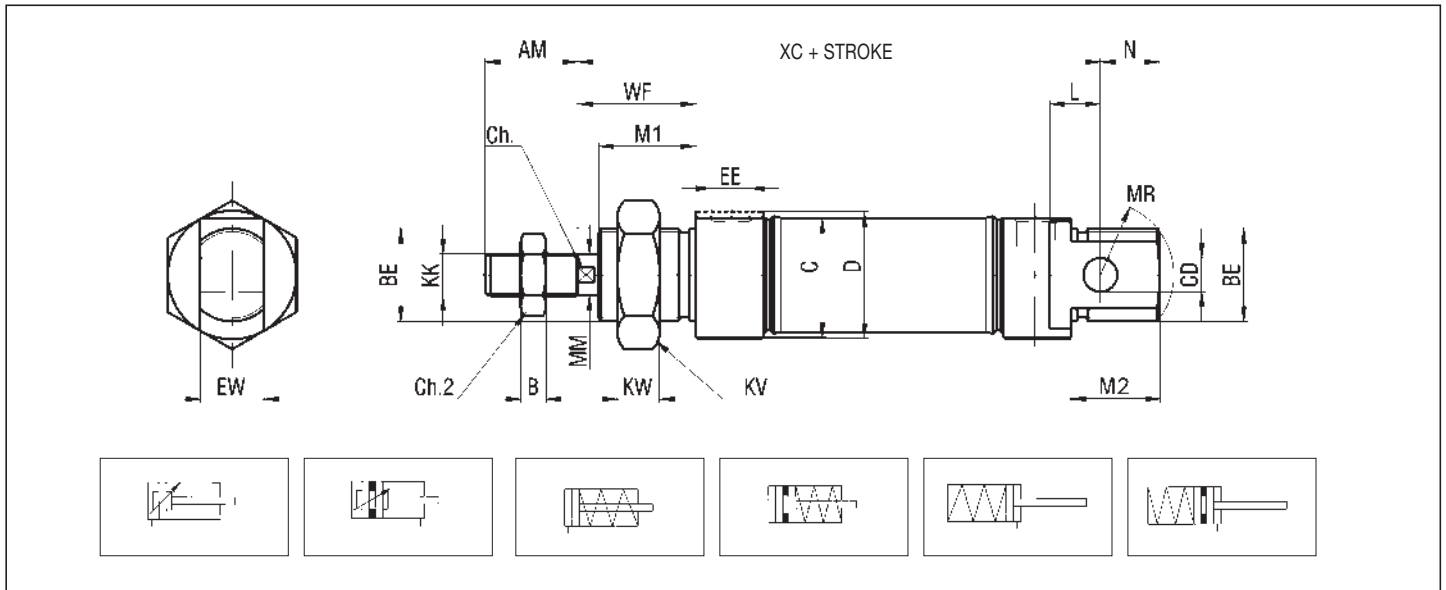

P.S.: End cap nut and rod nut supplied as standard in AISI 304 stainless steel

DIMENSIONS AND WEIGHTS BASIC CYLINDER UP Ø 16 ÷ 25

Ø	AM*	B	BE*	C	CD*	Ch*	Ch2	D*	EE*	ES	EW*	KK*	KV*	KW*	L*	LB	M1	M2	MM	MR*	N	WB	WF*	XC*	PESO (g)	INCR.(g) x10mm
16	16	4	M16x1,5	18	6	5	10	21	M5	-	12	M6	24	8	9	77	18	18	6	12	12	-	22	82	63	4,2
20	20	5	M22x1,5	25	8	7	13	26	G 1/8	8	16	M8	30	10	12	91	19	20	8	15	13	71	24	95	138	9,1
25	22	6	M22x1,5	28,5	8	9	17	30	G 1/8	10	16	M10x1,25	30	10	12	100	23	22	10	18	15	73	28	104	188,5	12,5

* STANDARDIZED DIMENSIONS

▲ Dimension "XC" for version "YE" is increased of 10 mm

THROUGH ROD Ø 16 ÷ 25

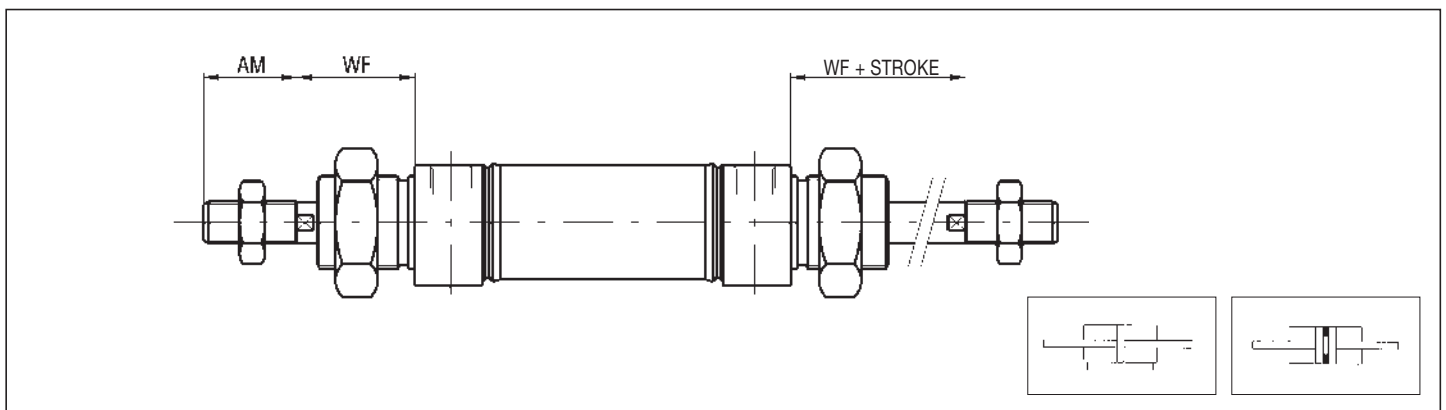

P.S.: End cap nuts and rod nuts supplied as standard in AISI 304 stainless steel

END CAP NUT - STAINLESS STEEL - UPDT Ø

Ø	DI	CH	S	WEIGHT (g)
16	M16x1,5	24	8	16
20-25	M22x1,5	30	10	25

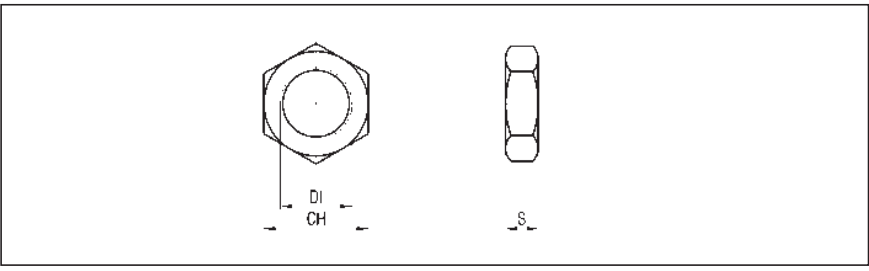

FLANGE - STAINLESS STEEL - UPF Ø

Ø	FB H13	LW	S	TF JS13	UF	UR	WEIGHT (g)
16	5,5	18	4	40	54	30	10
20	6,6	19	5	50	64	36	20
25	6,6	23	5	50	64	36	20

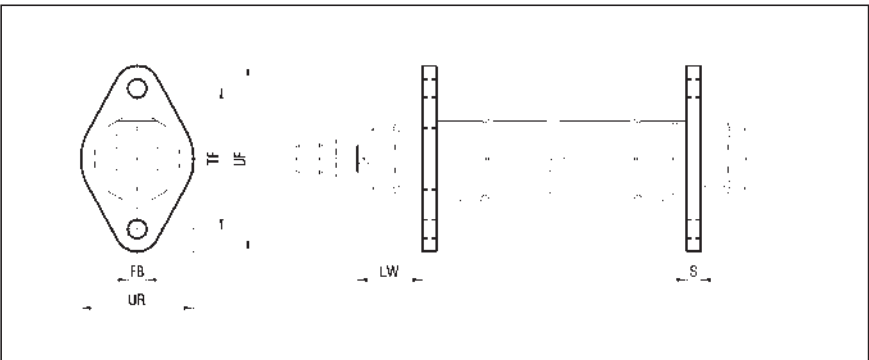

FOOT - STAINLESS STEEL - UPP Ø

Ø	AB H13	AU	LA	LB	LC	NH	R
16	5,5	12	19	74-81	28-35	20	13
20	6,6	13	21,5	91	45,5	25	18
25	6,6	13	21,5	95	45,5	25	18

Ø	S	TR	US	XS	XT	WEIGHT (g)
16	2	32	46	32	10	25
20	2,5	40	54	35	11	40
25	2,5	40	54	39	15	40

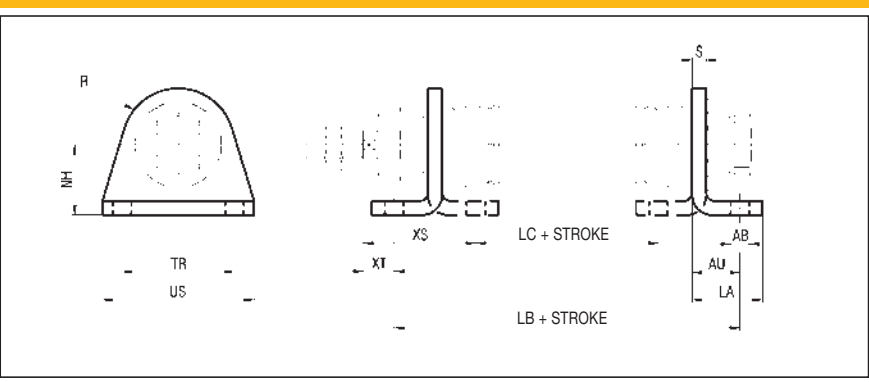

REAR HINGE - STAINLESS STEEL - UPSC Ø

Ø	CD f8	D H13	H	LA	LB	LC E9	LD
16	6	5,5	27	25	15	12,1	5
20	8	6,6	30	32	20	16,1	6
25	8	6,6	30	32	20	16,1	6

Ø	LE	LX	R	S	WEIGHT (g)
16	25	80	7	3	36
20	29,5	91	10	4	78
25	29,5	100	10	4	78

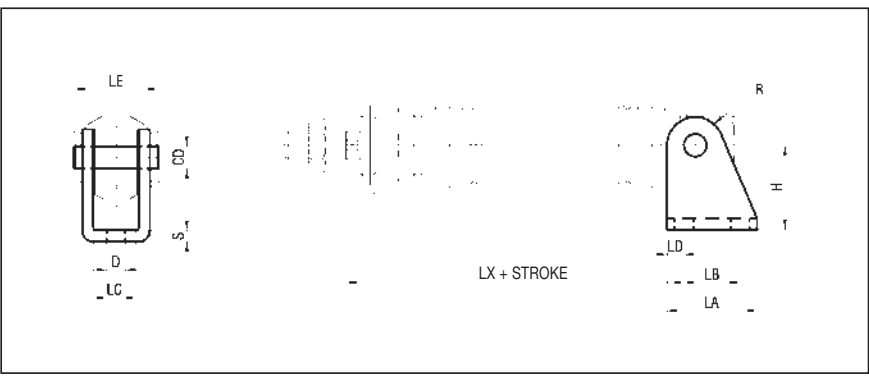

OTHER ACCESSORIES

- Piston rod locking unit series "WBZ" (see page 1.7)
- Guide unit series "WUG" (see page 1.8)

1

UP BASIC CYLINDER Ø 32 ÷ 50

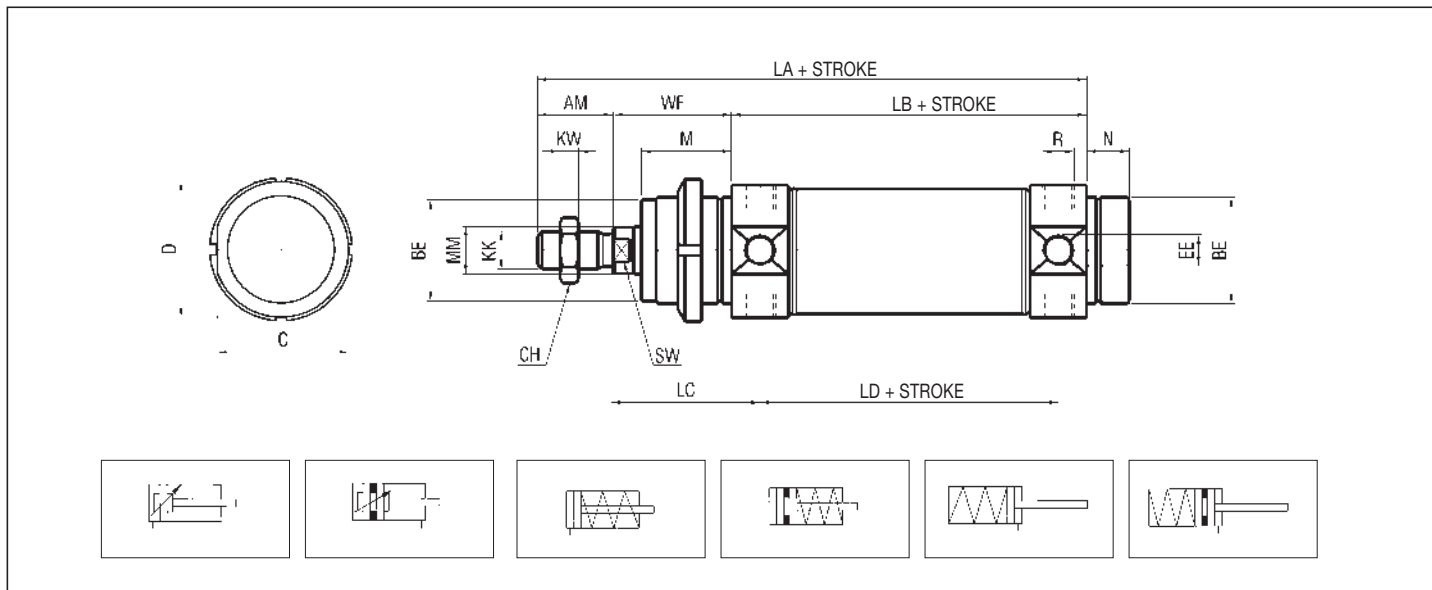

P.S.: End cap ring nut and rod nut supplied as standard in AISI 304 stainless steel

DIMENSIONS AND WEIGHTS BASIC CYLINDER UP Ø 32 ÷ 50

Ø	AM	BE	C	CH	D	EE	KK	KW	LA	LB	LC	LD	M	MM	N	R	SW	WF	XC	WEIGHT (g)	INCR. (g) x 10 mm
32	20	M30x1,5	36,5	17	38	G1/8	M10x1,25	6	154	96	47	78	30	12	14	M8x1	10	38	134	386	16
40	24	M38x1,5	44	19	46	G1/4	M12x1,25	7	182	113	57	89	35	16	16	M10x1	12	45	158	690	26
50	32	M45x1,5	55	24	57	G1/4	M16x1,5	8	202	120	62	96	38	20	18	M12x1,5	16	50	170	1265	34

THROUGH ROD Ø 32 ÷ 50

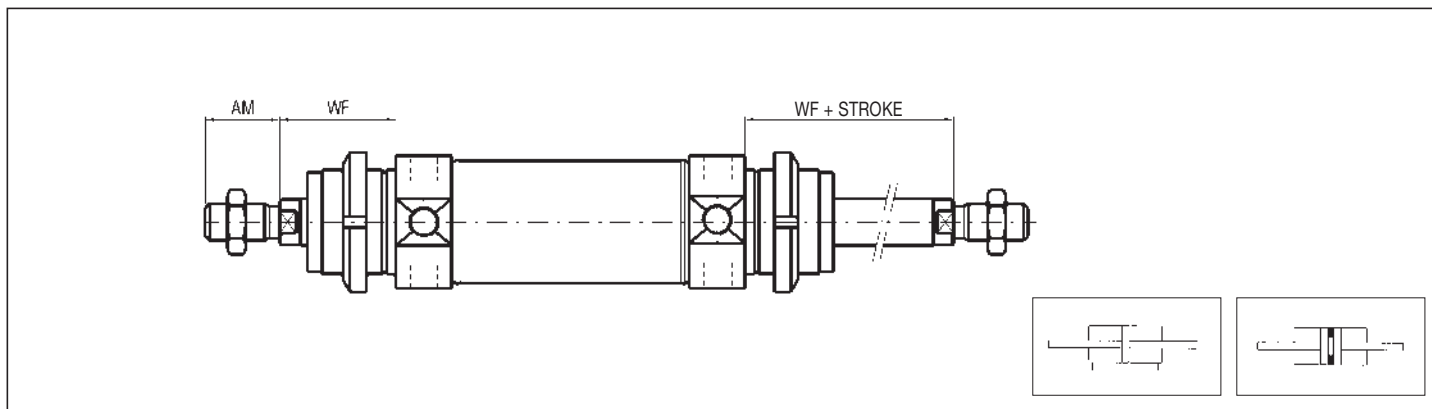

P.S.: End cap ring nuts and rod nuts supplied as standard in AISI 304 stainless steel

Accessories
AISI 304 stainless steel
fixings for round cylinders Ø 32 ÷ 50

series **UP**

1

RING NUT - STAINLESS STEEL - UPG Ø

Ø	d	D	S	WEIGHT (g)
32	M30x1,5	45	7	43
40	M38x1,5	50	8	80
50	M45x1,5	58	9	122

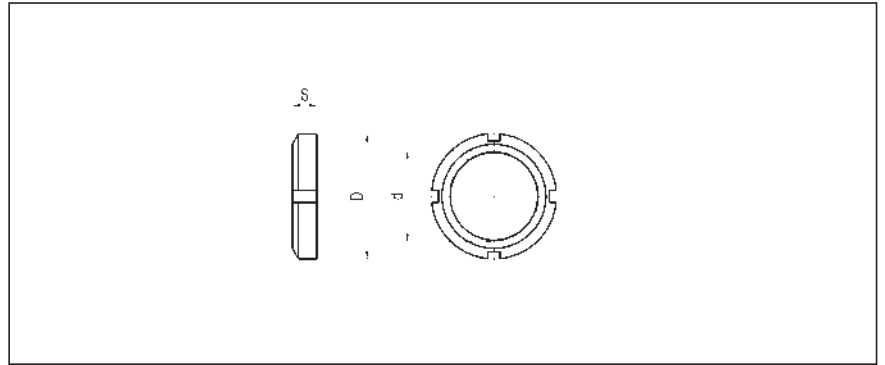

FLANGE/FOOT - STAINLESS STEEL - UPPF Ø

Ø	AB	AU	HA	HB	HC	LA	LB	LC
32	7	14	14	49	28	21	124	76
40	9	20	18	58	30	30	153	83
50	9	20	20	70	40	30	160	92

Ø	NH	S	TB	TR	TS	XS	XT	WEIGHT (g)
32	28	4	14	52	66	48	24	98
40	33	5	20	60	88	60	25	183
50	40	6	20	70	90	64	30	276

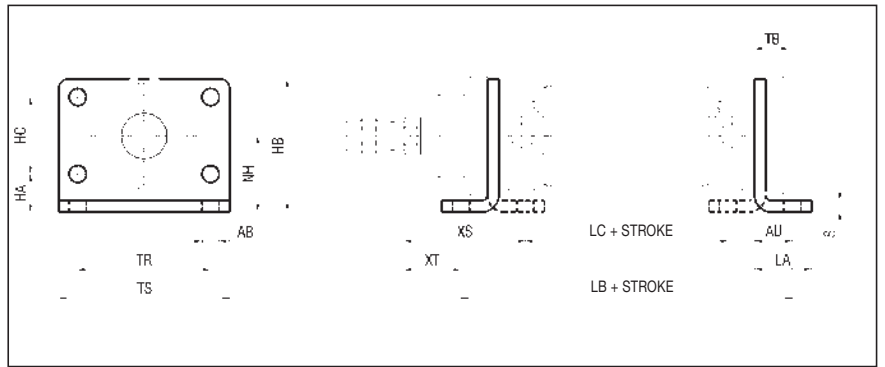

REAR HINGE - STAINLESS STEEL - UPSC Ø

Ø	CH	E	G	H	L	LA	LB
32	13	7	20	35	125	20	46,1
40	17	9,5	27	40	146	28	56,1
50	19	10	30	45	158	36	69,1

Ø	LC	NA	NB	R	S	WEIGHT (g)
32	58	24	40	8	4	150
40	70	30	50	9,5	5	259
50	86	34	54	10	6	403

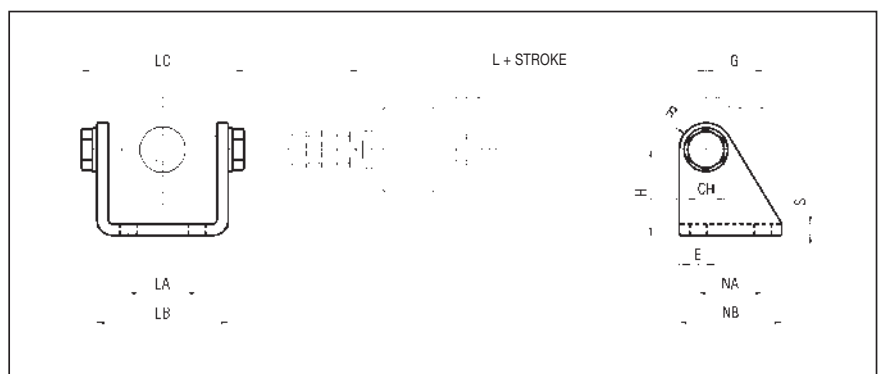

PIVOT (pair) - STAINLESS STEEL - UPT Ø

Ø	D	H	LA	LB	CH	WEIGHT (g)
32	10	51	47	125	5	10
40	12	61	57	146	6	20
50	14	75	62	158	6	40

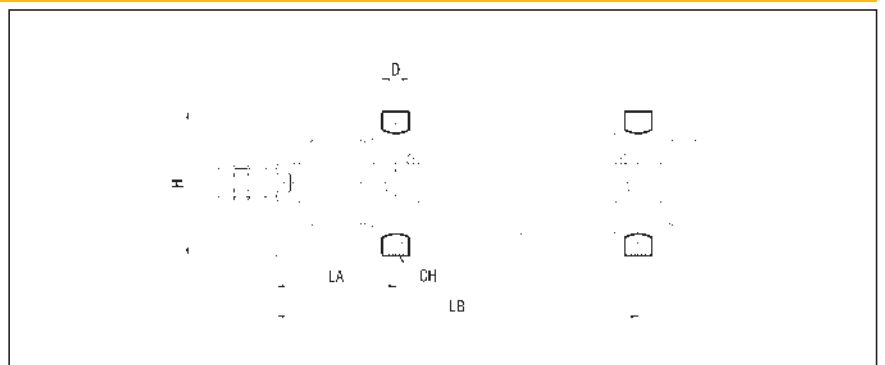

“Clean profile” cylinders to ISO 15552 standard

series X

1

DESCRIPTION

Pneumatic cylinders series “X” comply with ISO 15552 standard, being in this way completely interchangeable with the well-known cylinders to ISO 6431 standard, defining the dimensions of both the “nude” cylinder than assembled with fixings. They’re available in the bores from Ø 32 to Ø 100 and the cylinder barrel, made in extruded aluminium alloy, has some pits (“T”-shaped slots) on three sides where it’s possible to mount directly the new magnetic sensors series FM100. This peculiarity allows to leave the dimensions of the cylinders unchanged, keeping the mentioned sensors, completely embedded and granting them a better protection. The dynamic seals are made in high performances polyurethane with standard working temperature between -35°C and +80°C. Among all the available versions, a special mention deserves the non-rotating piston rod one with a particular section, made of AISI 304 stainless steel supplied as standard. The compact and advanced design makes the series “X” a product aesthetically appealing yet useful. In fact, thanks to proper cover strips that give the cylinders a really “clean profile”, the cylinders are not subject to receive dirt and so they result suitable also for “difficult” environments like the food one. A further feature is the possibility to assemble some series of valves directly on the cylinder barrel thanks to the brackets type “X/P/M..” (see page 1.24).



MATERIALS

End caps	Painted die-cast aluminium alloy
Cylinder barrel	Extruded profile, 20 µm anodized aluminium alloy
Screws	Steel (self-forming)
Piston rod	C45 chromium-plated steel AISI 303 rolled stainless steel
Rod nut	Steel Stainless steel
Piston rod bearing	Bronze-iron 20%, sintered, self-lubricating
Piston	Techno-polymer (supplied with and without magnet) Aluminium alloy for high temperatures
Seals	Polyurethane Viton®
Cover strips	Polyvinyl chloride

TECHNICAL DATA

Operating pressure	1 ÷ 10 bar
Working temperature	0 ÷ +80°C (with dry air -35°C) 0 ÷ +150°C with seals for high temperature (with dry air -10°C)
Fluid	Filtered, unlubricated or continuous lubricated compressed air
Versions	Double acting; Single acting front spring; Single acting rear spring; Through rod; Double push tandem; Double stroke tandem; Opposed tandem
Bore	Ø 32, 40, 50, 63, 80, 100
Port size	Ø 32 = G 1/8 Ø 40 - 50 = G 1/4 Ø 63 - 80 = G 3/8 Ø 100 = G 1/2
Standard strokes (mm)	25, 50, 75, 80, 100, 125, 150, 160, 200, 250, 300, 400 320, 350, 500, 550, 600, 650, 700, 800, 900, 1000
Decelerators lenght	Ø 32 40 50 60 80 100 mm 24 29 29 35 35 40
Maximum stroke (mm)	Ø 32 ÷ 100 = 3000
Max. stroke single acting (mm)	Ø 32 ÷ 100 = 50

ORDER KEY

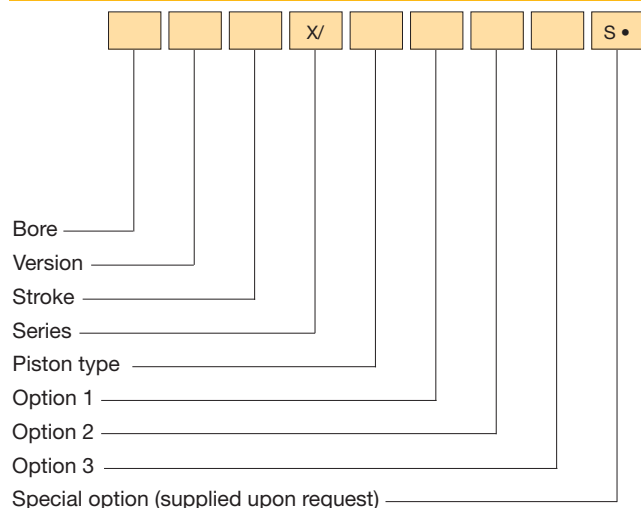

P.S.: Magnetic sensors FM100-FM157-FM158 (see chapter magnetic sensors from page 1.93)
• See technical data on page 0.12

ORDER EXAMPLES

Cylinder Ø 50, double acting, 100 mm stroke, non-magnetic piston type, fit for piston rod locking unit 50/100 X/NZ

Cylinder Ø 63, through rod, 150 mm stroke, magnetic piston type, stainless steel piston rod with cover strips 63R150 X/M14

Cylinder Ø 80, double stroke tandem, 50 mm stroke 1 + 100 mm stroke 2, magnetic piston type 80P50+100 X/M

VERSION

/ Double acting	T Double push tandem
S Single acting front spring	P Double stroke tandem
Y Single acting rear spring	V Opposed tandem
R Through rod	

PISTON TYPE

N Non-magnetic	M Magnetic
----------------	------------

OPTION 1

Z Fit for piston rod locking unit	A Stainless steel non-rotating piston rod
-----------------------------------	---

OPTION 2

1 Stainless steel piston rod and rod nut*	3 Stainless steel piston rod and rod nut and seals for high temperatures**
2 Seals for high temperatures**	

OPTION 3

4 Cover strips for magnetic sensors slots***
--

* Supplied as standard with option “A” (non-rotating piston rod)
** Supplied only with non-magnetic piston type and standard piston rod
*** Supplied as standard for big slot

SPARE PARTS

SEALS KIT	
Polyurethane	Ø/SG/X
Through rod polyurethane	Ø/SG/R/X
For high temperatures	Ø/SG/X2
Through rod for high temperatures	Ø/SG/R/X2

1

X BASIC CYLINDER

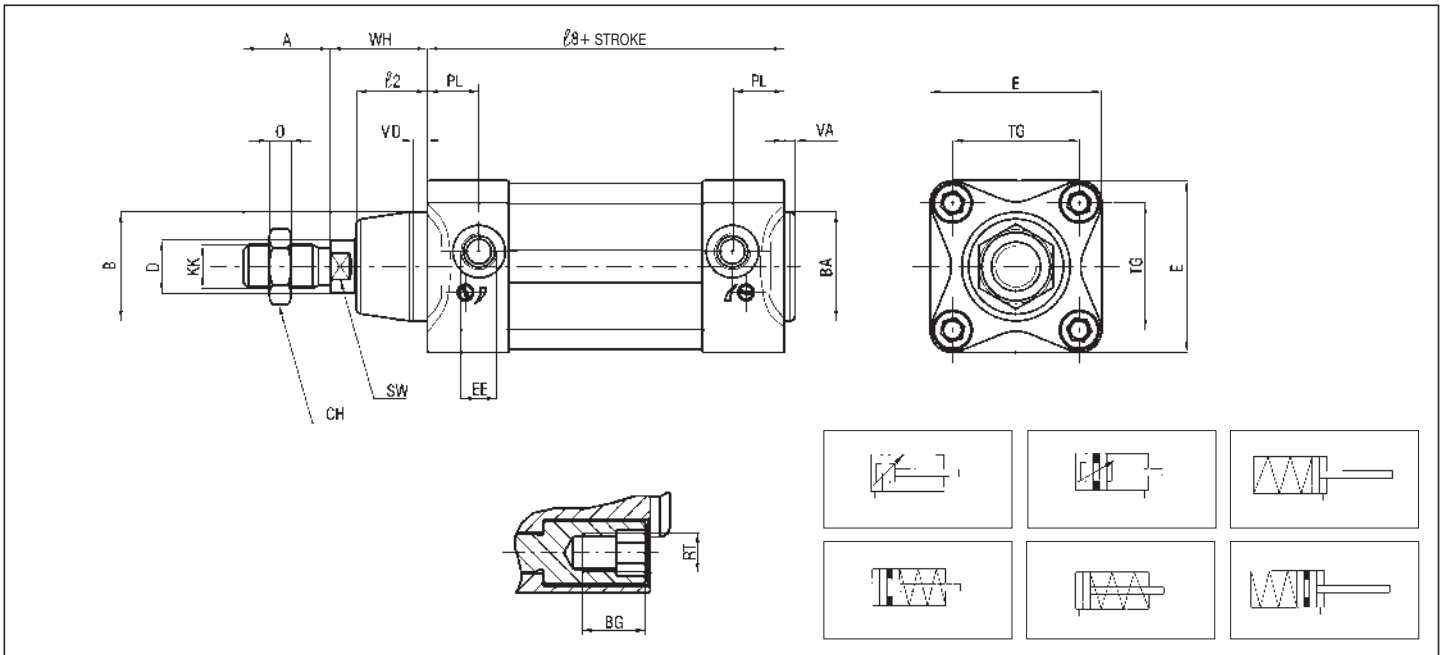

P.S.: Rod nut supplied as standard

DIMENSIONS AND WEIGHTS BASIC CYLINDER

Ø	A*	BA* B*	BG*	CH	RT*	E*	EE*	G	D	KK*	l	l2*	l8*	O	PL*	R	SW*	TG*	VA* VD*	WB	WH*	WEIGHT (g)	INCR. (g) every 10 mm
32	22	30	16	17	M6	47	G1/8	27	12	M10x1,25	160	20	94	6	18	9	10	32,5	3	86	26	690	30
40	24	35	16	19	M6	52	G1/4	31	16	M12x1,25	185	22	105	7	20,5	9	13	38	3	100	30	900	45
50	32	40	16	24	M8	63	G1/4	30	20	M16x1,5	172	26	106	8	19	9	17	46,5	3	127	37	1240	60
63	32	45	16	24	M8	75	G3/8	35,5	20	M16x1,5	197	27	121	8	22	9	17	56,5	4	127	37	1750	80
80	40	45	16	30	M10	93	G3/8	36	25	M20x1,5	216	29	128	9	23	9	22	72	4	156	46	3580	100
100	40	55	16	30	M10	113	G1/2	39	25	M20x1,5	234	35	138	9	24	9	22	89	4	161	51	5270	120

* STANDARDIZED DIMENSIONS

THROUGH ROD

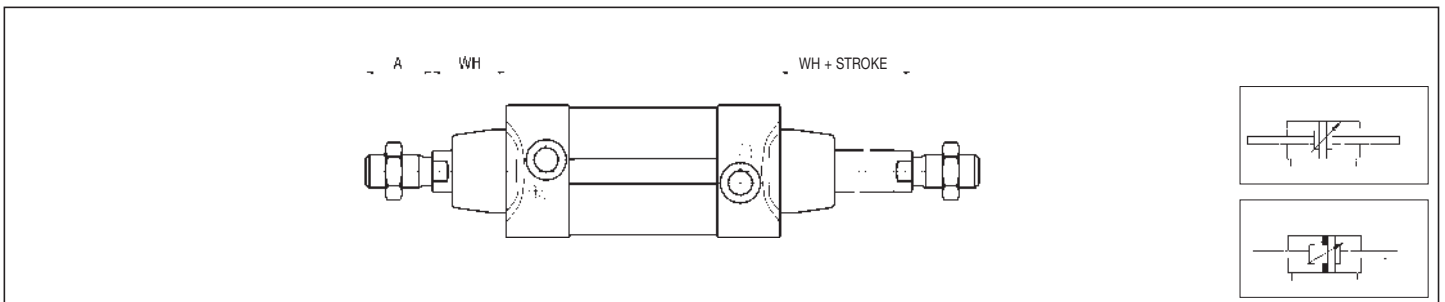

P.S.: Rod nuts supplied as standard

NON-ROTATING PISTON ROD

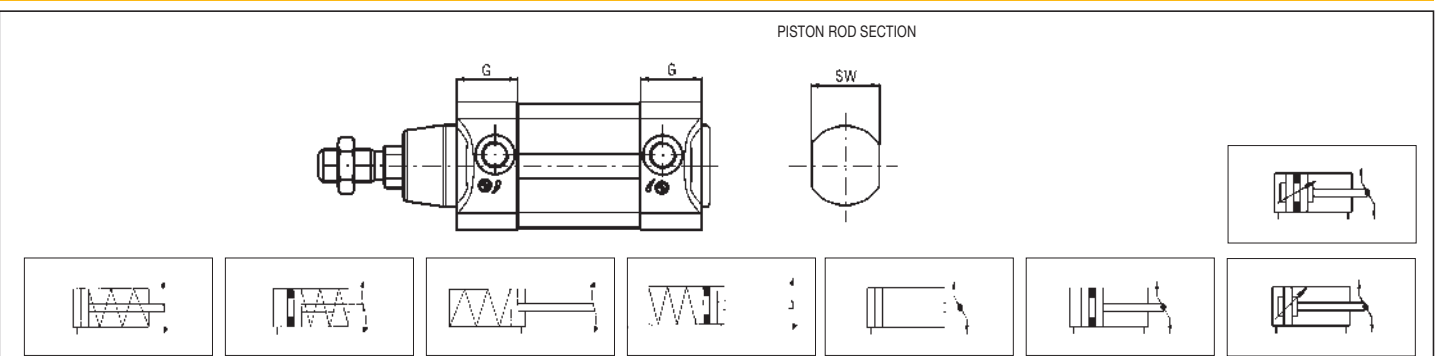

P.S.: Rod nut supplied as standard

DOUBLE PUSH TANDEM

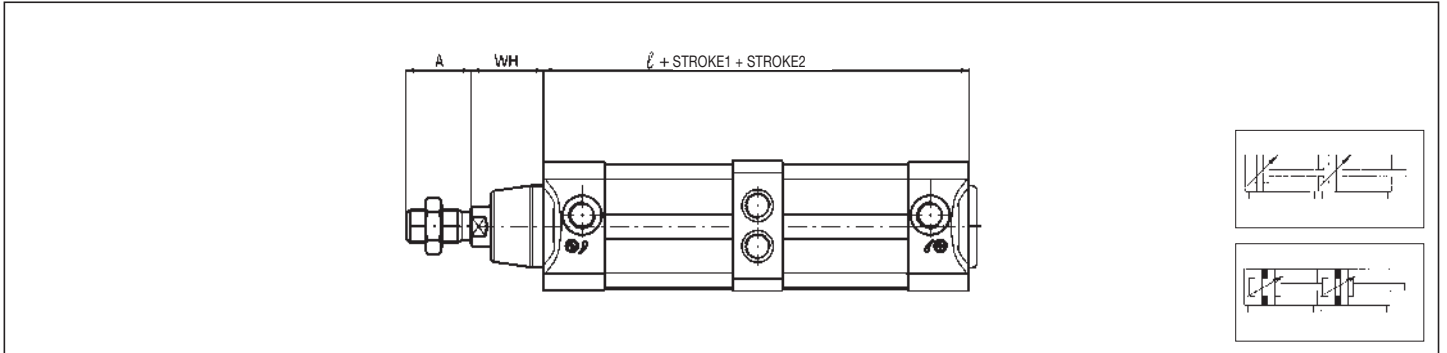

P.S.: Rod nut supplied as standard

DOUBLE STROKE TANDEM

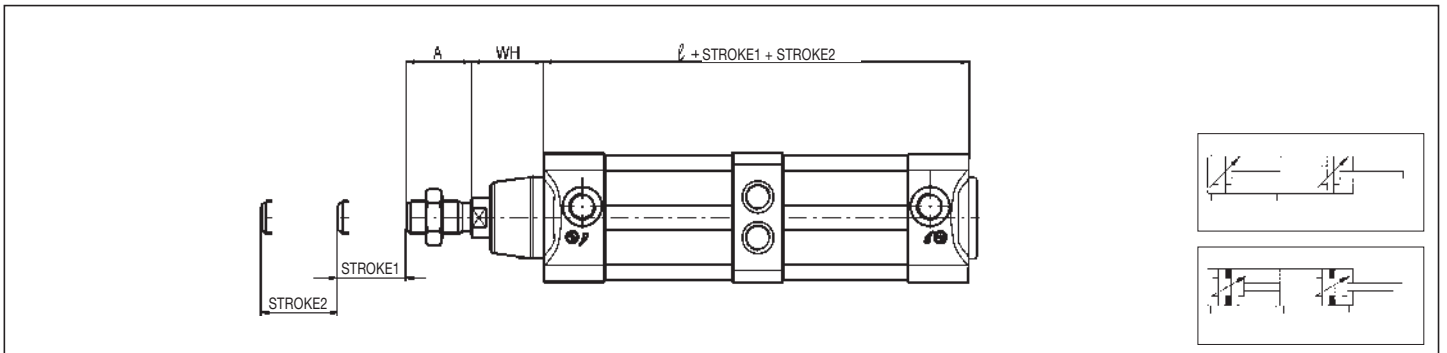

P.S.: Rod nut supplied as standard

OPPOSED TANDEM

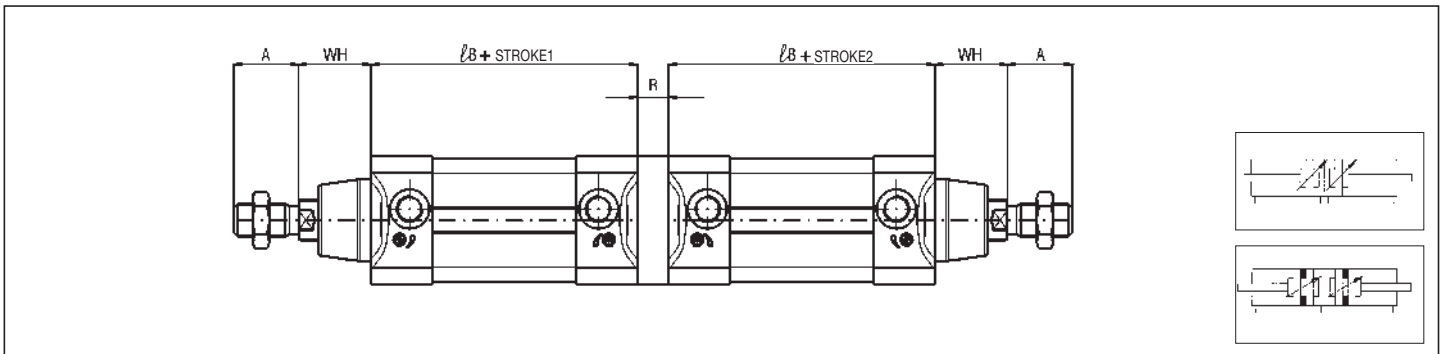

P.S.: Rod nuts supplied as standard

FIT FOR PISTON ROD LOCKING UNIT

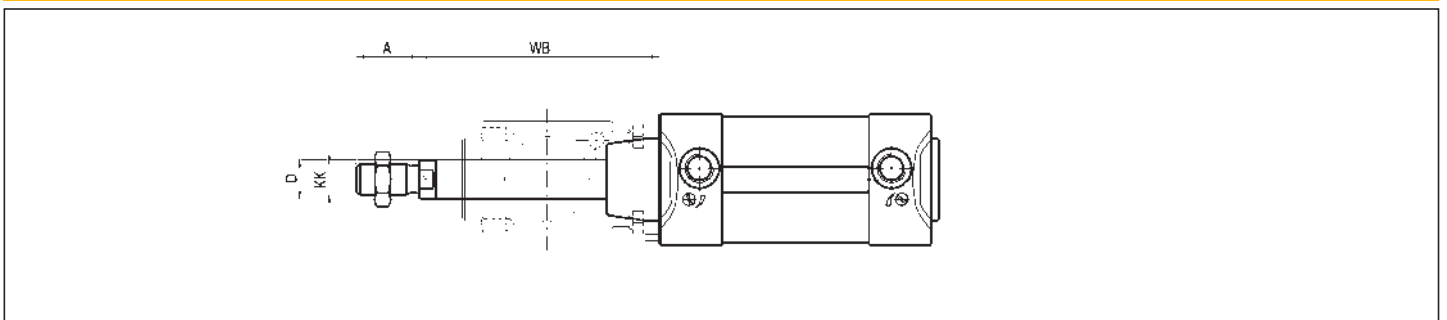

P.S.: Rod nut supplied as standard

1

SMALL SLOT COVER STRIP - X/CP

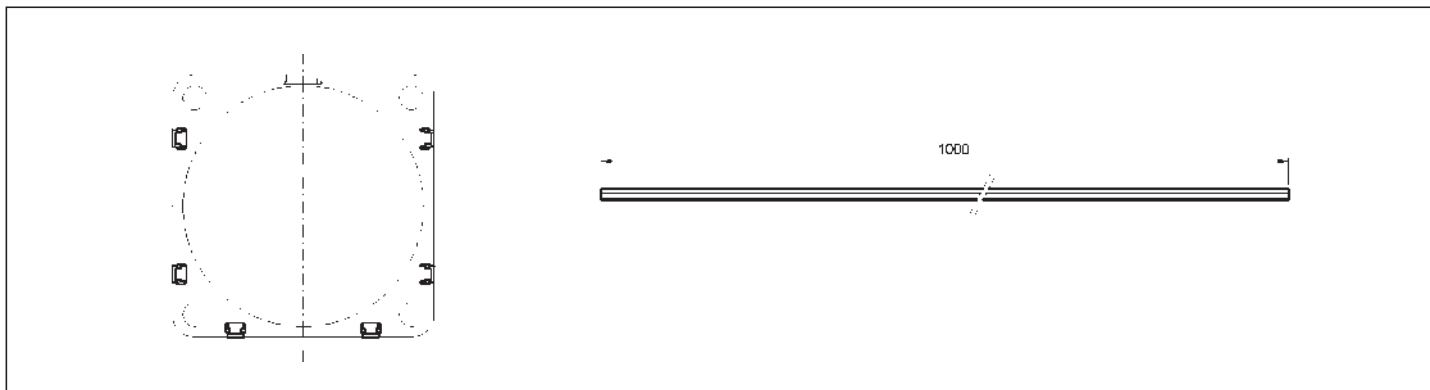

BIG SLOT COVER STRIP - X/CG

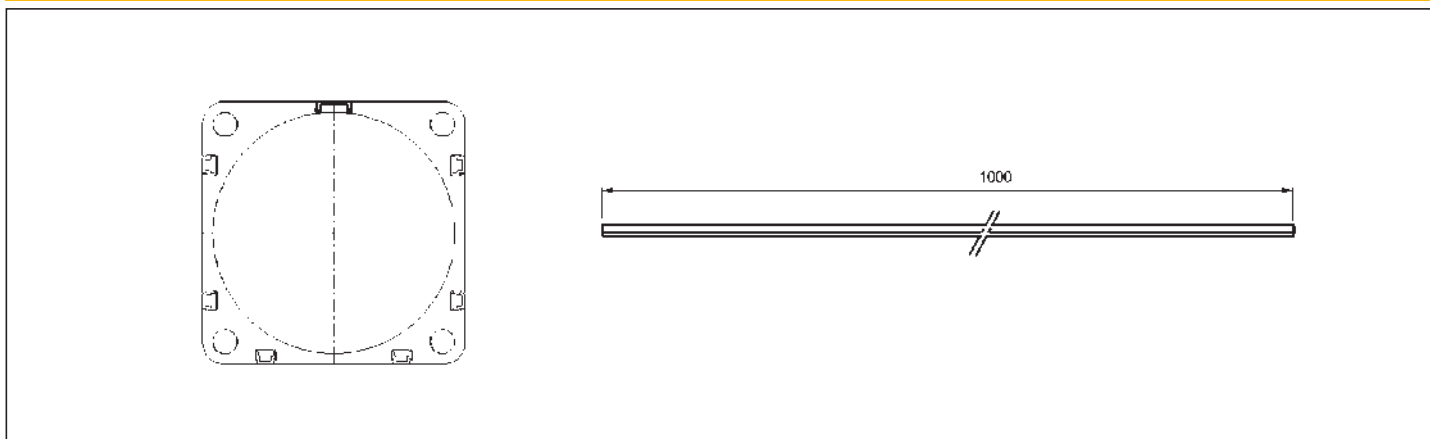

FIXING BRACKETS FOR "T" SLOTS - X/P/M..

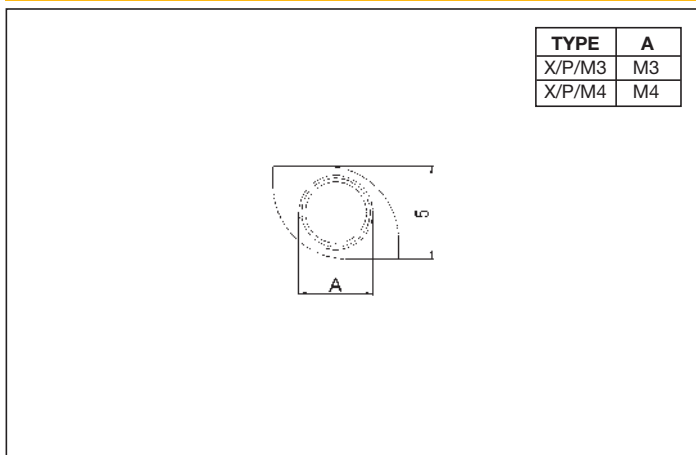

EXAMPLE OF ASSEMBLING OF VALVES MEV-MEK/CYLINDER

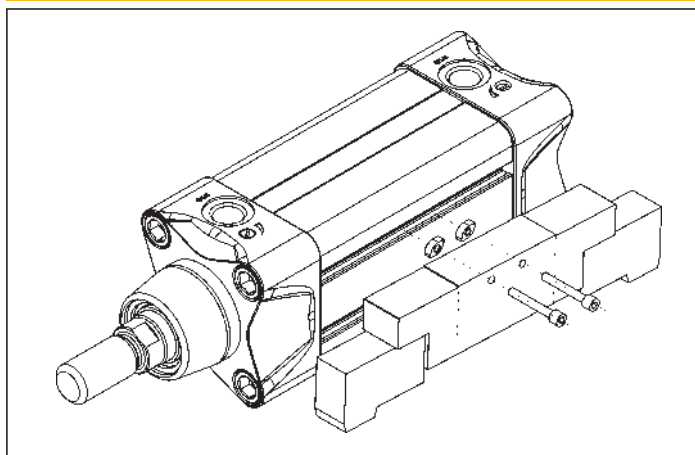

TECHNICAL INFORMATION FIXING BRACKETS

These brackets, with vertical insertion, allow to assembling directly on the cylinder barrel some series of valves and can be used even as reference point for the replacement of magnetic sensors.

Tie rods cylinders to ISO 15552 standard

series CPUI

1



DESCRIPTION

Cylinders series "CPUI" comply with ISO 15552 standard, being in this way completely interchangeable with the well-known cylinders to ISO 6431 standard. They're available from Ø 32 to Ø 200. These cylinders are supplied cushioned as standard and, in the version with magnetic piston type can be supplied with magnetic sensors.

TECHNICAL DATA

Operatin pressure	1 ÷ 10 bar
Working temperature	0 ÷ +80 °C (-20 °C with dry air) 0 ÷ +150 °C with seals for high temperatures (-10 °C with dry air)
Fluid	Filtered, unlubricated or continuous lubricated compressed air
Versions	Double acting; Single acting front spring; Single acting rear spring; Through rod; Double push tandem; Double stroke tandem; Opposed tandem
Bore	Ø 32, 40, 50, 63, 80, 100, 125, 160, 200
Port size	Ø 32 = G 1/8 Ø 40 - 50 = G 1/4 Ø 63 - 80 = G 3/8 Ø 100 - 125 = G 1/2 Ø 160 - 200 = G 3/4
Standard strokes (mm)	25, 50, 75, 80, 100, 125, 150, 160, 175, 200, 250, 300, 320, 350, 400, 450, 500, 550, 600, 650, 700, 800, 900, 1000
Decelerators lenght	Ø 32 40 50 63 80 100 125 160 200 mm 21 23 26 30 33 37 37 40 40
Max strokes (mm)	Ø 32 ÷ 200 = 3000
Max strokes single act. (mm)	Ø 32 ÷ 63 = 50; Ø 80 - 100 = 100

MATERIALS

End caps	Aluminium alloy, cataphoresis-treated
Cylinder barrel	Ø 32 ÷ 125: extruded profile, 20 µm anodized alluminium alloy Ø 125 ÷ 200: extruded tube, 20 µm anodized alluminium alloy
Tie rods, tie and rod nuts	Steel Stainless steel (supplied upon request for tie rods and tie nuts)
Piston rod	C45 chromium-plated steel AISI 303 rolled staines steel
Piston rod bearing	Bronze-Iron 20%, sintered, self-lubricating
Decelerator ogives	Aluminium alloy
Piston	NBR rubber block (supplied with and without magnet) Viton® (supplied only without non-magnetic piston)
Seals	NBR rubber Viton®

ORDER KEY

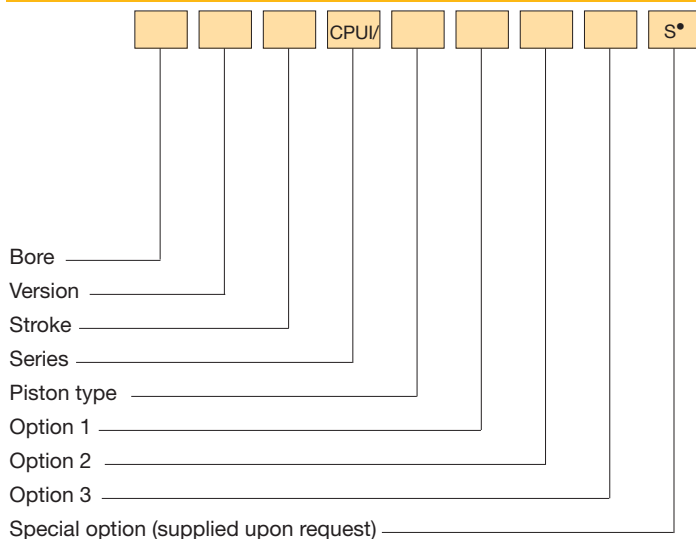

VERSION

/ Double acting	T Double push tandem
S Single acting front spring	P Double stroke tandem
Y Single acting rear spring	V Opposed tandem
R Through rod	

PISTON TYPE

N Non-magnetic	M Magnetic
----------------	------------

OPTION 1

Z Fit for piston rod locking unit *

OPTION 2

1 Stainless steel piston rod and rod nut	3 Stainless steel piston rod and rod nut and seals for high temperatures**
2 Seals for high temperatures**	

OPTION 3

5 Extruded profile barrel (only for Ø 125)

* Supplied from Ø 32 al Ø 125

** Supplied only with non-magnetic piston type

N.B.: *Magnetic sensors* FM 100 - FM157 - FM158 (see chapter magnetic sensors from page1.93)

• See technical data on page 0.12

ORDER EXAMPLES

Cylinder Ø50, double acting, 100 mm stroke, magnetic piston type, fit for piston rod locking unit 50/100 CPUI/MZ

Cylinder Ø63, through rod, 150 mm stroke, magnetic piston type, stainless steel piston rod 63R150 CPUI/M1

Cylinder Ø80, double push tandem, 50 mm stroke, magnetic piston type 80T50 CPUI/M

Cylinder Ø80, double stroke tandem, 50 mm stroke 1 + 100 mm stroke 2, magnetic piston type 80P50+100 CPUI/M

Cylinder Ø80, opposed tandem, 50 mm stroke 1 + 50 mm stroke 2, magnetic piston type, stainless steel piston rod 80V50+50 CPUI/M1

SPARE PARTS

SEALS KIT		
Non-magnetic piston type	NBR	Ø/SG/CPUI/N
	Through rod, NBR	Ø/SG/R/CPUI/N
	For high temperature	Ø/SG/CPUI/N2
	Through rod	Ø/SG/R/CPUI/N2
Magnetic piston type	NBR	Ø/SG/CPUI/M
	Through rod, NBR	Ø/SG/R/CPUI/M

series CPUI

Tie rods cylinders
to ISO 15552 standard

1

CPUI BASIC CYLINDER

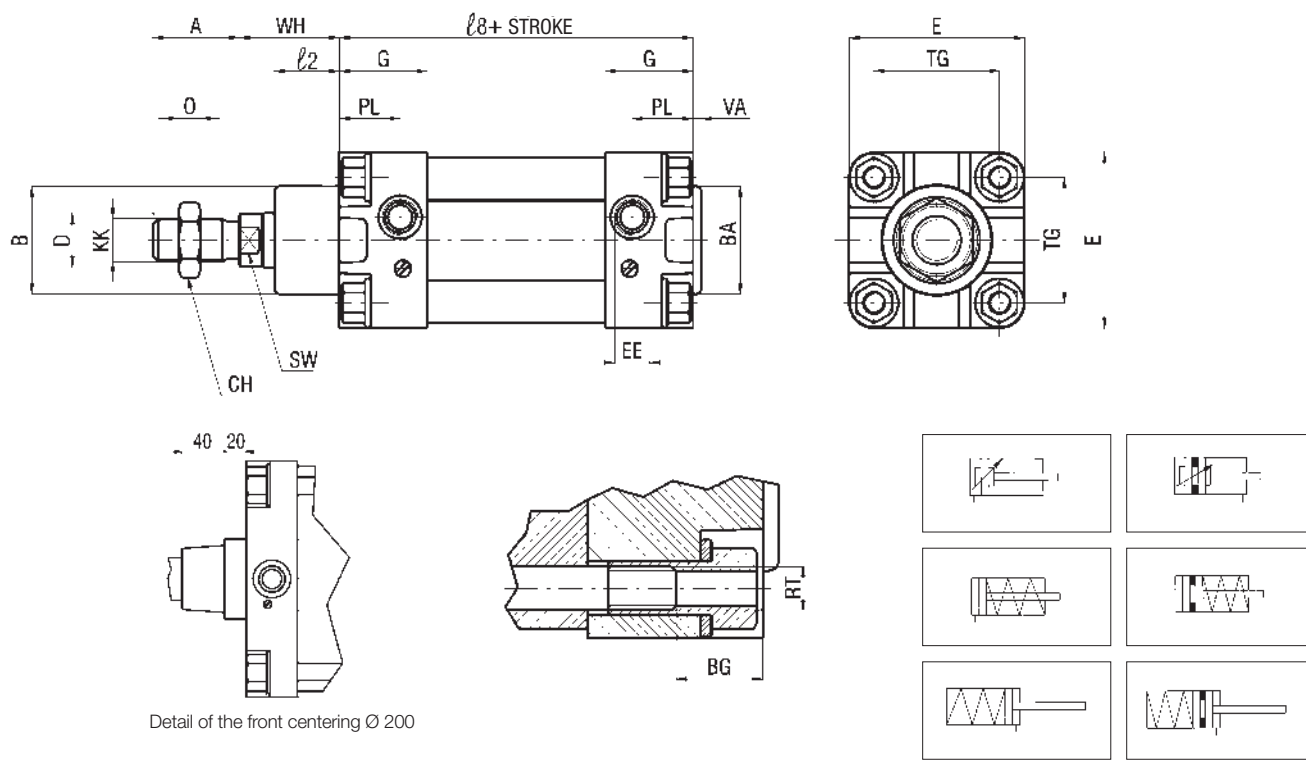

P.S.: Rod nuts supplied as standard

DIMENSIONS AND WEIGHTS BASIC CYLINDER

Ø	A*	BA* B*	BG*	CH	RT*	E*	EE*	G	D	KK*	l	l2*	l8*	O	PL*	R	SW*	TG*	VA*	WB	WH*	WEIGHT (g)	INCREMENT (g) every 10 mm
32	22	30	16	17	M6	47	G 1/8	27	12	M10x1,25	160	15	94	6	18	7	10	32,5	3	86	26	520	28
40	24	35	16	19	M6	54	G 1/4	30	16	M12x1,25	185	20	105	7	20	7	13	38	3	100	30	810	36
50	32	40	16	24	M8	65	G 1/4	32,5	20	M16x1,5	172	24	106	8	22,5	7	17	46,5	3	127	37	1235	55
63	32	45	16	24	M8	75	G 3/8	37	20	M16x1,5	197	24	121	8	23,5	9	17	56,5	4	127	37	1790	58
80	40	45	16	30	M10	95	G 3/8	37	25	M20x1,5	216	32	128	9	23	9	22	72	4	156	46	2900	80
100	40	55	16	30	M10	114	G 1/2	40	25	M20x1,5	234	36	138	9	24,5	9	22	89	4	161	51	4080	104
125	54	60	20	41	M12	140	G 1/2	46	32	M27x2	268	50	160	12	24	-	27	110	6	205	65	6070	126
160	72	65	24	55	M16	180	G 3/4	50	40	M36x2	310	60	180	15	24	-	36	140	6	-	80	13100	210
200	72	75	24	55	M16	220	G 3/4	48	40	M36x2	310	60	180	15	24	-	36	175	6	-	95	18200	290

* STANDARDIZED DIMENSIONS

THROUGH ROD

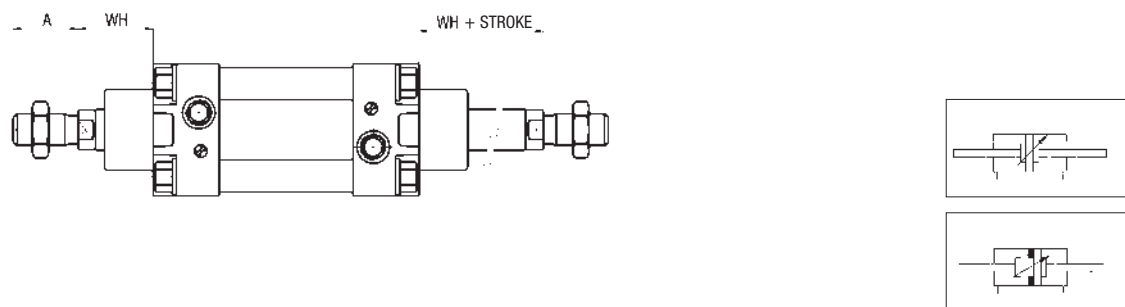

P.S.: Rod nuts supplied as standard

DOUBLE PUSH TANDEM

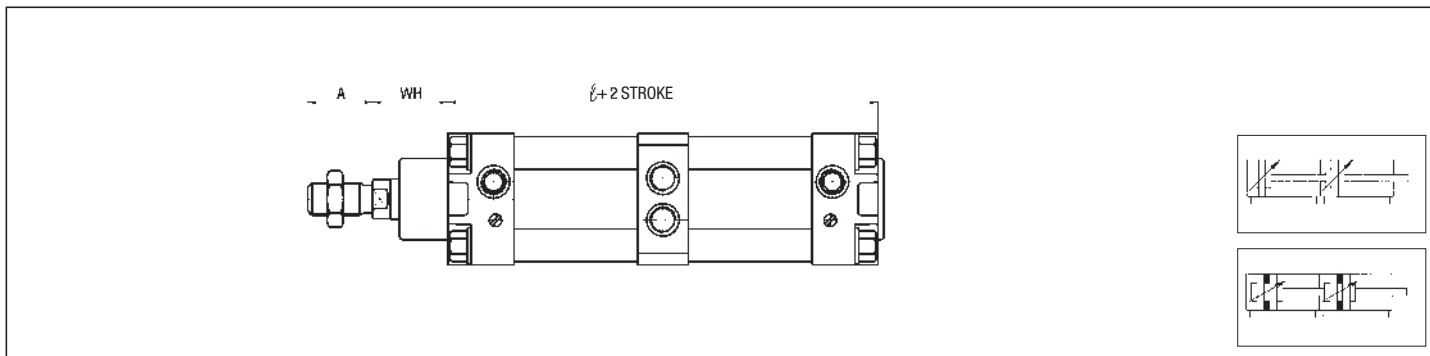

P.S.: Rod nut supplied as standard

DOUBLE STROKE TANDEM

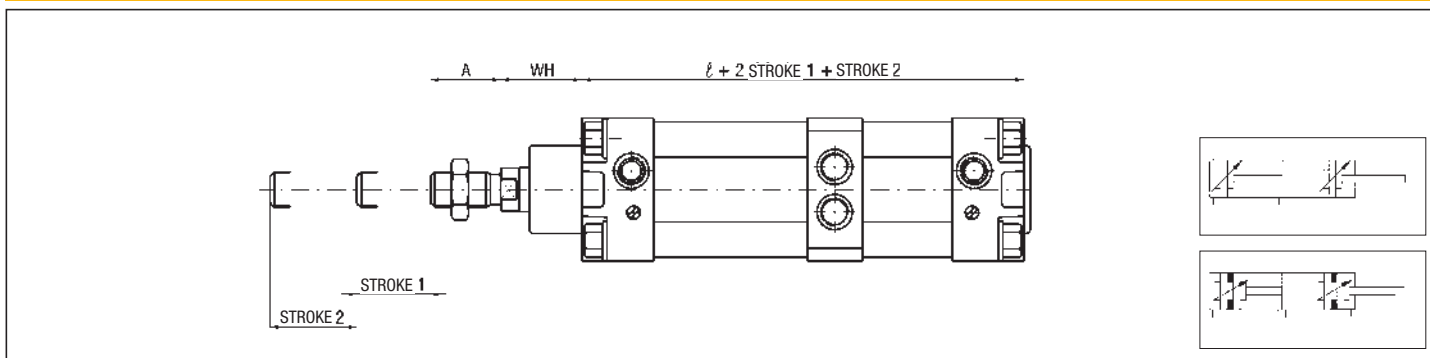

P.S.: Rod nut supplied as standard

OPPOSED TANDEM

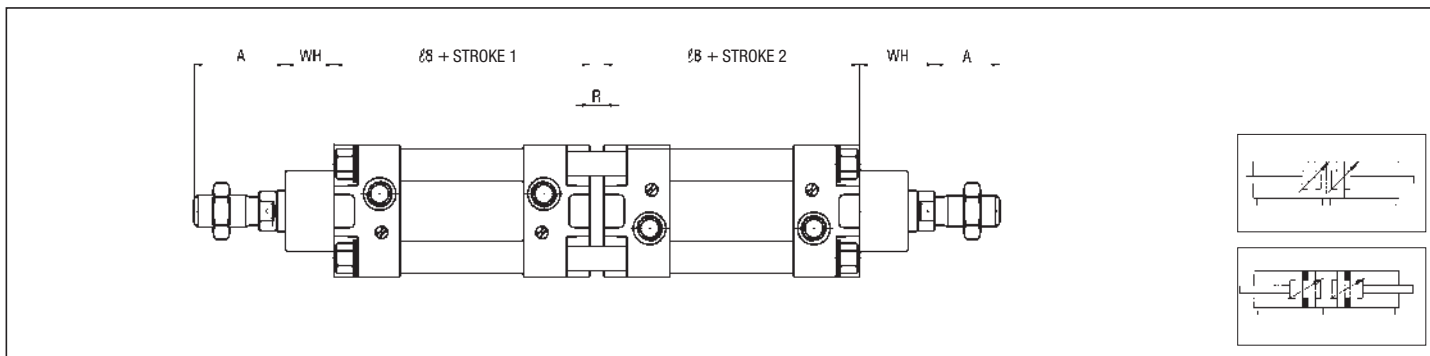

P.S.: Rod nuts supplied as standard

FIT FOR PISTON ROD LOCKING UNIT

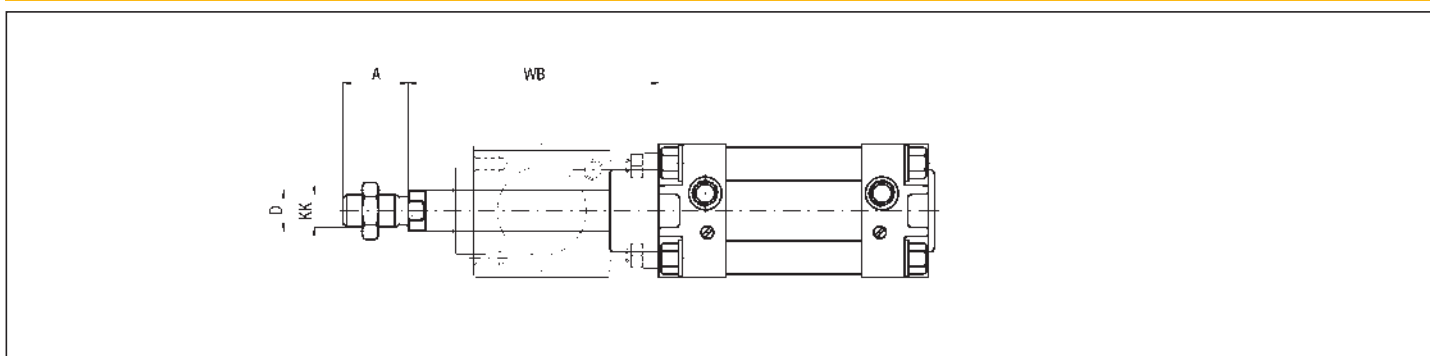

P.S.: Rod nut supplied as standard

1

FLANGE - STEEL - CPU1/F Ø (supplied with screws)

Ø	D H11	FB H13	E	MF JS14	R JS14	TF JS14	UF
32	30	7	45	10	32	64	80
40	35	9	52	10	36	72	90
50	40	9	65	12	45	90	110
63	45	9	75	12	50	100	120
80	45	12	95	16	63	126	150
100	55	14	115	16	75	150	170
125	60	16	140	20	90	180	205
160	65	18	180	20	115	230	260
200	75	22	220	25	135	270	300

Ø	W	ZF	WEIGHT (g)
32	16	130	190
40	20	145	246
50	25	155	478
63	25	170	622
80	30	190	1430
100	35	205	1986
125	45	245	3750
160	60	280	6350
200	70	300	11350

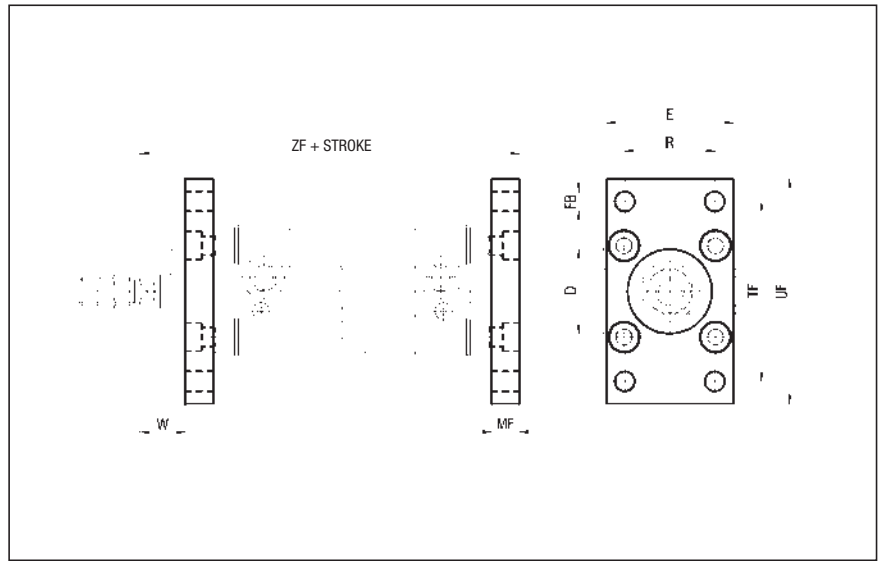

AVAILABLE IN AISI 316 STAINLESS STEEL FROM Ø 32 TO Ø 100, SCREWS EXCLUDED

FOOT - STEEL - CPU1/PB Ø (supplied with screws)

Ø	AB H14	AH JS15	AT	AU	E	F	SA
32	7	32	4	24	45	35	142
40	9	36	4	28	52	36	161
50	9	45	5	32	65	47	170
63	9	50	5	32	75	45	185
80	12	63	6	41	95	55	210
100	14	71	6	41	115	57	220
125	16	90	8	45	140	70	250
160	18	115	10	60	180	75	300
200	22	135	12	70	220	100	320

Ø	TR JS14	XA	WEIGHT (g)
32	32	144	66
40	36	163	78
50	45	175	168
63	50	190	190
80	63	215	382
100	75	230	452
125	90	270	1090
160	115	320	1188
200	135	345	3450

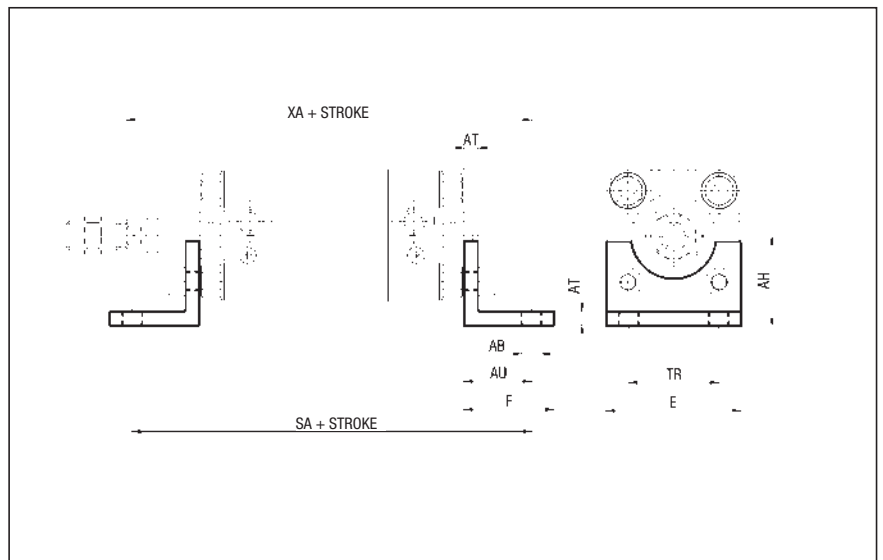

AVAILABLE IN AISI 316 STAINLESS STEEL FROM Ø 32 TO Ø 100, SCREWS EXCLUDED

FRONT FEMALE HINGE - NOT CONFORM TO ISO STANDARD - ALUMINIUM - CPU1/CFA Ø (supplied with screws)

Ø	CB	CD H9	E	FL	L	UB h14	WEIGHT (g)
32	26	10	45	22	13	45	48
40	28	12	52	25	16	52	75
50	32	12	65	27	16	60	124
63	40	16	75	32	21	70	192
80	60	16	95	36	22	90	380
100	70	20	115	41	27	110	620
125	90	25	140	50	30	130	1180
160	90	30	180	55	35	170	1780
200	110	30	220	60	35	170	2900

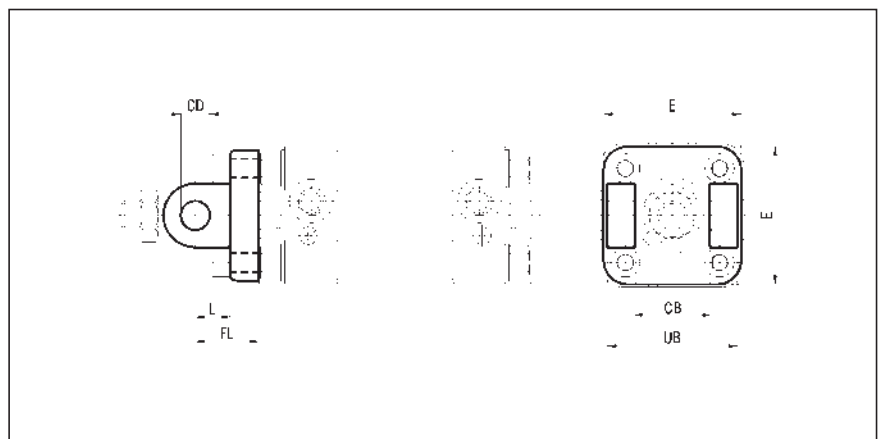

REAR FEMALE HINGE
(Supplied with screws)

- ALUMINIUM - CPUI/CF Ø
- ALUMINIUM WITH BUSHINGS - CPUI/CF Ø B
- STEEL - CPUI/CF Ø AC

Ø	CB H14	CD H9	E	FL	L	L4	UB h14
32	26	10	45	22	13	5,5	45
40	28	12	52	25	16	5,5	52
50	32	12	65	27	16	6,5	60
63	40	16	75	32	21	6,5	70
80	50	16	95	36	22	10	90
100	60	20	115	41	27	10	110
125	70	25	140	50	30	10	130
160	90	30	180	55	35	10	170
200	90	30	220	60	35	11	170

Ø	XD	WEIGHT	
		ALL. (g)	STEEL (g)
32	142	48	138
40	160	75	230
50	170	124	338
63	190	192	540
80	210	380	1000
100	230	620	1700
125	275	1180	3350
160	315	1780	5750
200	335	2900	8900

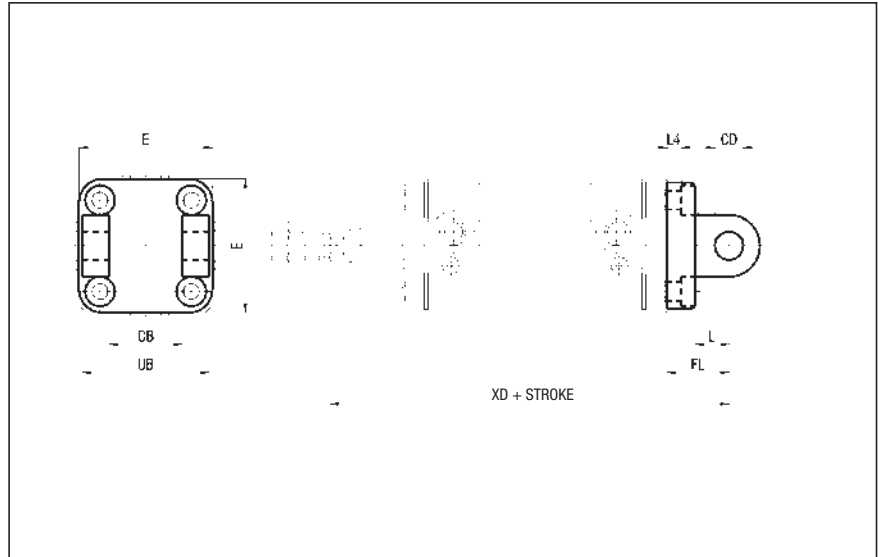

AVAILABLE IN AISI 316 STAINLESS STEEL FROM Ø 32 TO Ø 125, SCREWS EXCLUDED

PIVOT FOR REAR FEMALE HINGE (ALUMINIUM) - STEEL - CPU/CPUI/SEC Ø
(STEEL) - GALVANIZED NITRIDED STEEL - CPUI/SEC Ø AC

Ø	BU	EK f7	EL	WEIGHT (g)
32	53	10	46	32
40	60	12	53	52
50	68	12	61	60
63	78	16	71	122
80	98	16	91	152
100	118	20	111	290
125	139	25	132	530
160	178	30	171,5	978
200	178	30	171,5	978

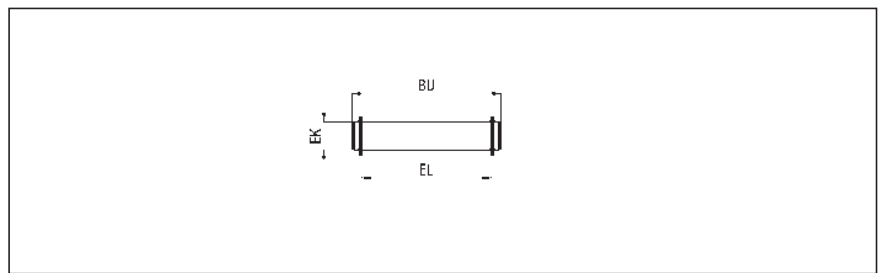

AVAILABLE IN AISI 316 STAINLESS STEEL FROM Ø 32 TO Ø 125

MALE HINGE
(Supplied with screws)

- ALUMINIUM - CPUI/CM Ø
- ALUMINIUM WITH BUSHINGS - CPUI/CM Ø B
- STEEL - CPUI/CM Ø AC

Ø	CD H9	E	EW	FL	L	L4	XD
32	10	45	26	22	13	5,5	142
40	12	52	28	25	16	5,5	160
50	12	65	32	27	16	6,5	170
63	16	75	40	32	21	6,5	190
80	16	95	50	36	22	10	210
100	20	115	60	41	27	10	230
125	25	140	70	50	30	10	275
160	30	180	90	55	35	10	315
200	30	220	90	60	35	11	335

Ø	WEIGHT	
	ALL. (g)	STEEL (g)
32	54	176
40	76	274
50	124	368
63	212	682
80	420	1196
100	666	2100
125	1264	3740
160	1846	5890
200	2950	8470

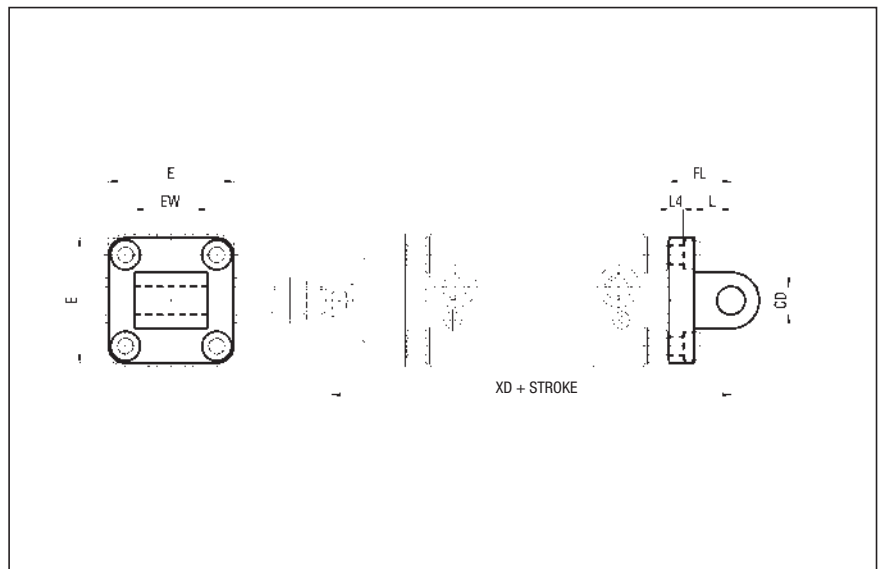

AVAILABLE IN AISI 316 STAINLESS STEEL FROM Ø 32 TO Ø 125, SCREWS EXCLUDED

SQUARE JOINT

- ALUMINIUM - CPUI/AS Ø
- STEEL - CPUI/AS Ø AC (FOR Ø 32 ÷ 125)

Ø	PH JS15	CK H9	EM	GL JS14	RA JS14	UR	BT	L5
32	32	10	26	21	18	31	8	1,6
40	36	12	28	24	22	35	10	1,6
50	45	12	32	33	30	45	12	1,6
63	50	16	40	37	35	50	14	1,6
80	63	16	50	47	40	60	14	2,5
100	71	20	60	55	50	70	17	2,5
125	90	25	70	70	60	90	20	3,2
160	115	30	90	97	88	126	25	4
200	135	30	90	105	90	130	30	4

Ø	BR	S5 H13	K1 JS14	K2	XD	WEIGHT ALL. (g)	WEIGHT STEEL (g)
32	10	6,6	38	51	142	56	158
40	11	6,6	41	54	160	139	238
50	13	9	50	65	170	142	418
63	15	9	52	67	190	200	526
80	15	11	66	86	210	312	1055
100	19	11	76	96	230	656	1360
125	22,5	14	94	124	275	826	-
160	31,5	14	118	156	315	2600	-
200	31,5	18	122	162	335	3250	-

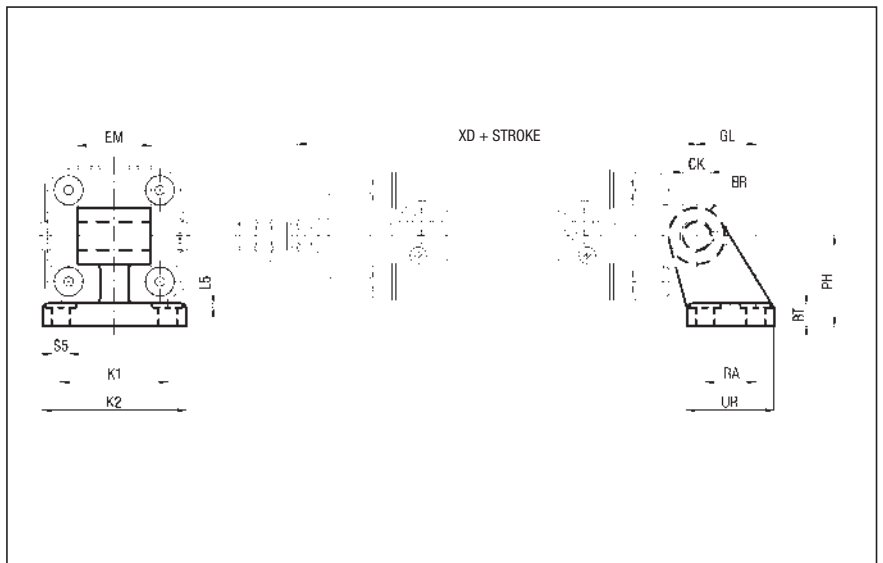

AVAILABLE IN AISI 316 STAINLESS STEEL FROM Ø 32 TO Ø 125

NARROW REAR FEMALE HINGE - ALUMINIUM - CPUI/CFS Ø

(Supplied with screws) - STEEL - CPUI/CFS Ø AC (FOR Ø 32 ÷ 125)

Ø	CG D10	CP d12	B3	Ø CF F7	E	FM	L10	L11
32	14	34	3,3	10	45	22	9	16,5
40	16	40	4,3	12	52	25	9	18
50	21	45	4,3	16	65	27	11	22
63	21	51	4,3	16	75	32	11	22
80	25	65	4,3	20	95	36	14	26
100	25	75	6,3	20	115	41	14	26
125	37	97	6,3	30	140	50	20	39
160	43	122	6,3	35	180	55	20	44
200	43	122	6,3	35	220	60	25	44

Ø	L4	XD	WEIGHT ALL. (g)	WEIGHT STEEL (g)
32	5,5	142	42	140
40	5,5	160	70	230
50	6,5	170	112	336
63	6,5	190	194	546
80	10	210	382	1190
100	10	230	610	1840
125	10	275	1100	3550
160	10	315	2000	-
200	11	335	3300	-

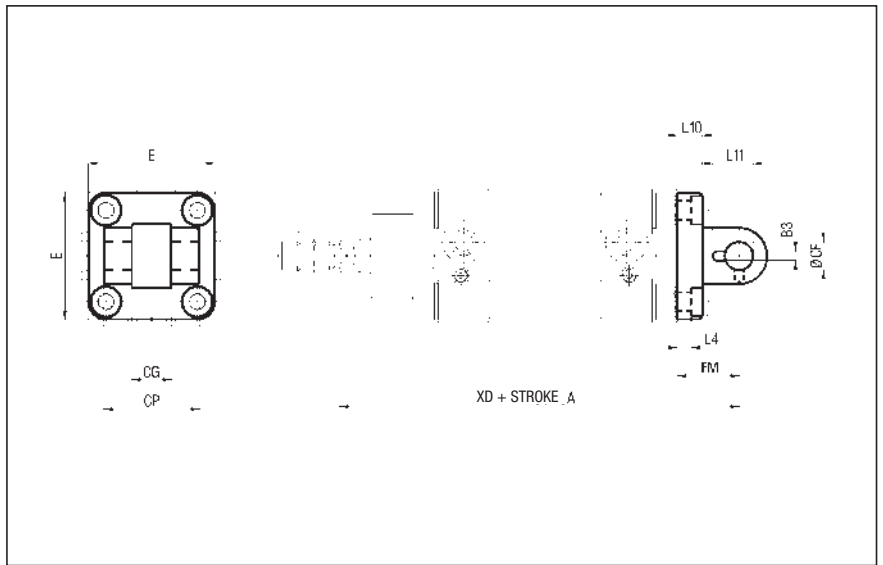

AVAILABLE IN AISI 316 STAINLESS STEEL FROM Ø 32 TO Ø 125, SCREWS EXCLUDED

NON-ROTATING PIVOT FOR NARROW REAR FEMALE HINGE - GALVANIZED NITRIDED STEEL - CPUI/SEC Ø AT

Ø	d4 H12	ØJK f7	L8	ES	L9	L5	G	WEIGHT (g)
32	3	10	14	32,5	4,5	41	4	26
40	4	12	16	38	6	48	4	42
50	4	16	20	43	6	54	5	84
63	4	16	20	49	6	60	5	94
80	4	20	24	63	6	75	6	184
100	4	20	24	73	6	85	6	208
125	6	30	36	94	9	110	7	606
160	6	35	41	119	9	135	7	974
200	6	35	41	119	9	135	7	974

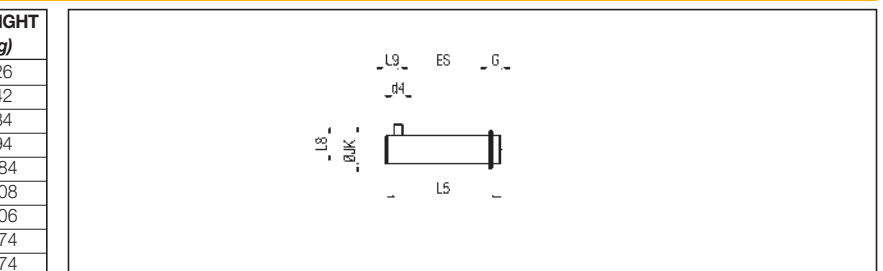

AVAILABLE IN AISI 316 STAINLESS STEEL FROM Ø 32 TO Ø 125

NARROW MALE HINGE WITH ARTICULATED HEAD (ISO 12240)
(Supplied with screws)

- ALUMINIUM - CPUI/CMSS Ø
- STEEL - CPUI/CMSS Ø AC (FOR Ø 32 ÷ 125)

Ø	ØCX H7	E	EN	MS	EU	G	DL
32	10	45	14	16	10,5	9	22
40	12	52	16	19	12	9	25
50	16	65	21	21	15	11	27
63	16	75	21	24	15	11	32
80	20	95	25	28,5	18	14	36
100	20	115	25	30	18	14	41
125	30	140	37	40	25	20	50
160	35	180	43	45	28	20	55
200	35	220	43	48	28	25	60

Ø	L4	XD	WEIGHT	
			ALL. (g)	ACC. (g)
32	5,5	142	62	158
40	5,5	160	100	254
50	6,5	170	180	360
63	6,5	190	244	588
80	10	210	476	1118
100	10	230	646	1810
125	10	275	1410	3500
160	10	315	2385	-
200	11	335	3860	-

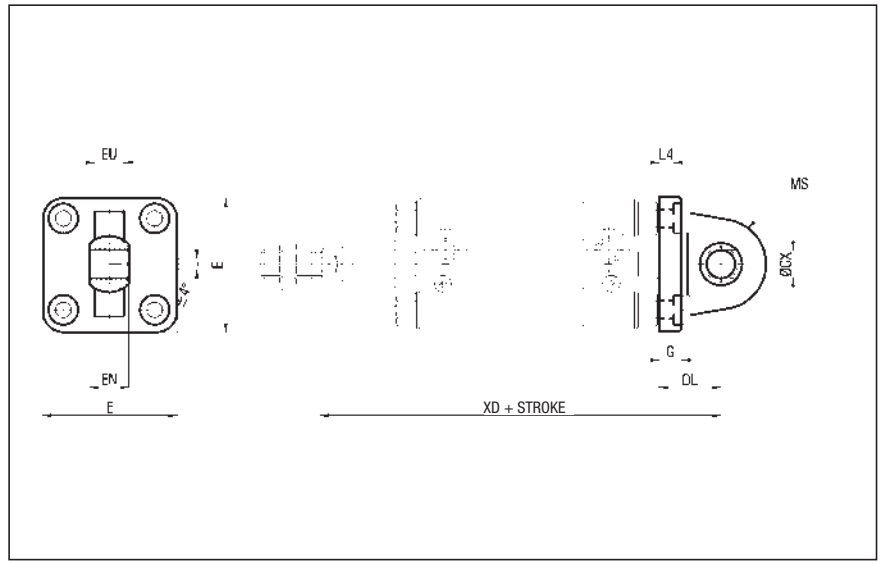

AVAILABLE IN AISI 316 STAINLESS STEEL FROM Ø 32 TO Ø 125, SCREWS EXCLUDED

SQUARE JOINT WITH ARTICULATED HEAD (ISO 12240) - STEEL- CPUI/ASSS Ø AC

Ø	CA JS15	BQ	CK H7	EM	G1 JS14	G2 JS14	G3	H6
32	32	10,5	10	14	21	18	31	10
40	36	12	12	16	24	22	35	10
50	45	15	16	21	33	30	45	12
63	50	15	16	21	37	35	50	12
80	63	18	20	25	47	40	60	14
100	71	18	20	25	55	50	70	15
125	90	25	30	37	70	60	90	20

Ø	K1 JS14	K2	L5	R	S5 H13	XD	WEIGHT (g)
32	38	51	1,6	15	6,6	142	178
40	41	54	1,6	18	6,6	160	268
50	50	65	1,6	20	9	170	458
63	52	67	1,6	23	9	190	550
80	66	86	2,5	27	11	210	970
100	76	96	2,5	30	11	230	1326
125	94	124	3,2	40	13,5	275	3000

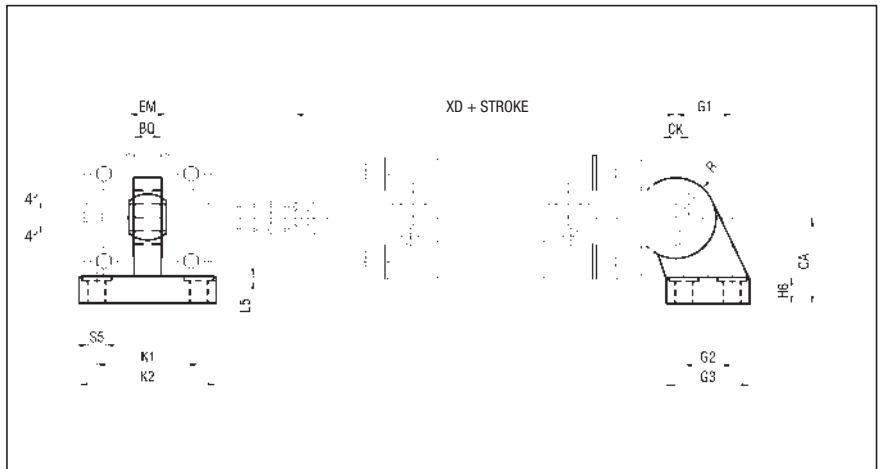

AVAILABLE IN AISI 316 STAINLESS STEEL FROM Ø 32 TO Ø 125

FLOATING HINGE - STEEL - CPUI/CTA Ø (Supplied with screws)

Ø	L1	LA	LB	TD e9	TL h14	TM h14	UW	WEIGHT (g)
32	14	19	127	12	12	50	46	137
40	19	20,5	144,5	16	16	63	59	385
50	19	27,5	152,5	16	16	75	69	513
63	24	25	170	20	20	90	84	1041
80	24	34	186	20	20	110	102	1563
100	29	37,6	203,5	25	25	132	125	3000

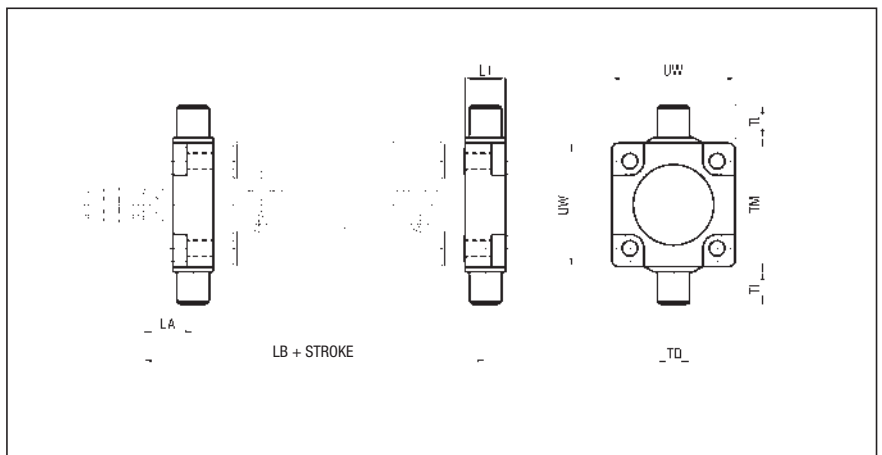

1

INTERMEDIATE HINGE - STEEL - EXTRUDED PROFILE - CPUI/CT Ø (Supplied with dowels)

Ø	M ± 0,3	N ± 0,3	TD e9	TK max	TL h14	TM h14	UW max	XV min	XV max	WEIGHT (g)
32	13,5	7	12	18	12	50	48,5	62	84	130
40	19	8	16	20	16	63	59	70	95	238
50	24,5	8	16	20	16	75	71	79,5	100,5	318
63	28	12	20	26	20	90	85	87	108	608
80	36,5	12	20	26	20	110	105	96	124	928
100	42,5	15	25	32	25	132	129	107	133	1562
125	59,5	15	25	33	25	160	154	127,5	163	2600

AVAILABLE IN AISI 316 STAINLESS STEEL FROM Ø 32 TO Ø 100, SCREWS EXCLUDED

P.S.: ADJUSTABLE POSITION (fixing through dowels)

ASSEMBLY: CPUI/CT Ø + cylinder series "CPUI"
type M/CPUI/CT Ø

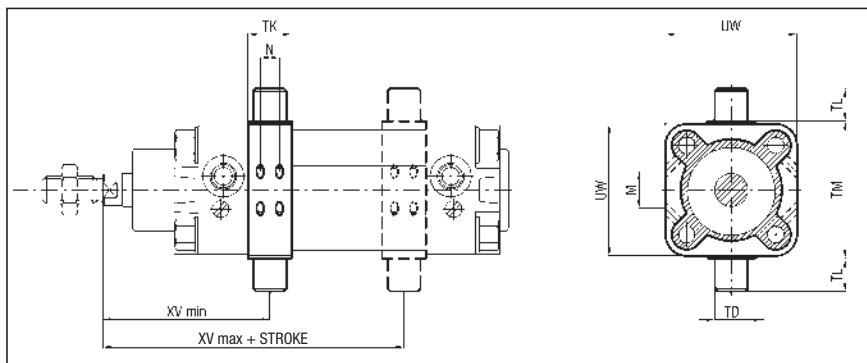

INTERMEDIATE HINGE - STEEL - "CLEAN PROFILE" - X/CT Ø (Supplied with dowels)

Ø	TK	TD e9	TL h14	TM 0/-0,3	UW1	UW2	XV min	XV max	WEIGHT (g)
32	18	12	12	50	70	50	56	85	250
40	20	16	16	63	78	62	63	95	410
50	20	16	16	75	91	74	66	96	530
63	25	20	20	90	94	88	75	108,5	775
80	25	20	20	110	130	109	78,5	115,5	1430
100	30	25	25	132	145	130	89	123	1950

AVAILABLE IN AISI 316 STAINLESS STEEL FROM Ø 32 TO Ø 100

P.S.: ADJUSTABLE POSITION (fixing through dowels)

ASSEMBLY: X/CT Ø + cylinder series "X"
type M/X/CT Ø

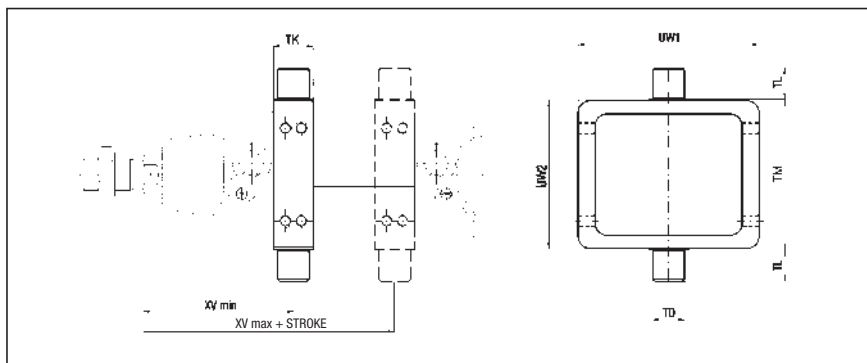

INTERMEDIATE HINGE - STEEL - EXTRUDED TUBE WITH TIE RODS - CX/CPUI/CT Ø (Supplied with dowels)

Ø	TK	M	TD e9	TL h14	TM h14	UW	XV min
125	32	12,25	25	25	160	155	127
160	40	16,25	32	32	200	190	150
200	40	16,25	32	32	250	240	163

Ø	XV max	WEIGHT (g)
125	163	2600
160	190	4300
200	207	7450

P.S.: - FIXED POSITION (specify dimension "XV", fixed on cylinder with completed threaded and galvanized tie rods type "S6", see on page 0.12)
- ADJUSTABLE POSITION (fixing through dowels)

ASSEMBLY (FIXED): CX/CPUI/CT Ø + cylinders series "CPUI S6"
type MF/CX/CPUI/CT Ø

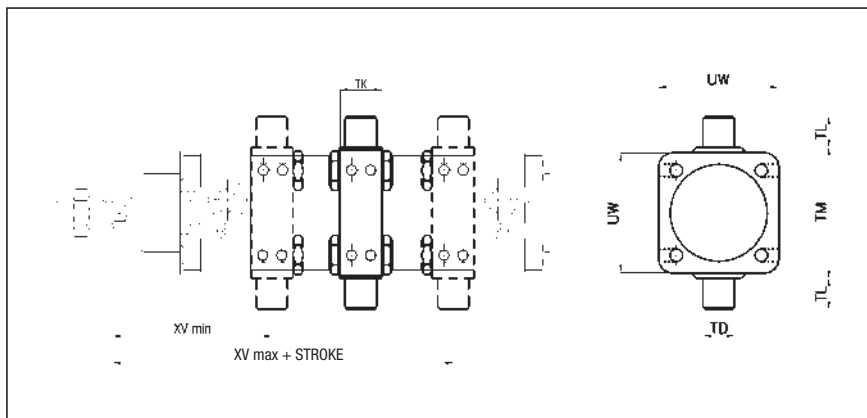

SUPPORT FOR INTERMEDIATE HINGE - STEEL - CPUI/SCT Ø

Ø	A	B1	B2	C	d1 F7	d2 H13	FN
32	32	46	18	10,5	12	6,6	30
40-50	36	55	21	12	16	9	36
63-80	42	65	23	13	20	11	40
100-125	50	75	28,5	16	25	14	50
160-200	60	92	40	22,5	32	18	60

Ø	XA	WEIGHT (g)
32	71	100
40-50	87-99	150
63-80	116-136	234
100-125	164-192	435
160-200	245-295	850

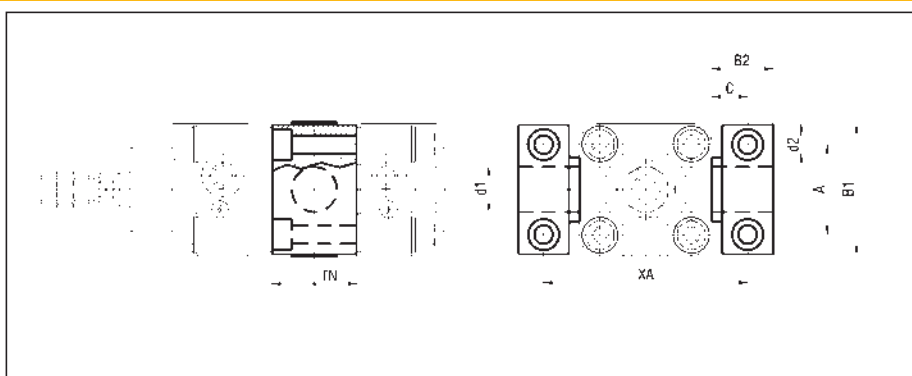

DESCRIPTION

Piston rod locking unit series “WBZ” is a mechanical device to fit on ISO 15552 cylinders (series X and CPUi); its function is to lock the piston rod in any position. This solution allows to lock the cylinder stroke each time that there’s a pressure fall. Locking force is, in any case, higher than the force given off by the cylinder fed at 10 bar. It has static operation (cylinder piston rod not moving); it’s necessary to preliminary stop the cylinder piston rod before proceeding with mechanical locking. Piston rod locking unit series “WBZ” must not be considered as a safety device.



1

TECHNICAL DATA

Release pressure	3 ÷ 6 bar with cylinder feed pressure 0 ÷ 10 bar							
Working temperature	0 ÷ +80 °C (-5 °C with dry air)							
Fluid	Filtered, unlubricated or continuous lubricated compressed air							
Size	32, 40, 50, 63, 80, 100, 125							
Port size	Ø 32 ÷ 63 = G 1/8 Ø 80 ÷ 125 = G 1/4							
Locking type	Mechanical – Only axial (bi-directional)							
Release	Through pneumatic control							
Condition in absence of pressure	Locked							
Locking force with static load	Size	32	40	50	63	80	100	125
	N	790	1240	1930	3060	5400	7700	12040

MATERIALS

Body	Anodized aluminium alloy
Blades	Brass
Pistons	Acetal resin
Seals	NBR rubber
Springs	Steel

ORDER KEY

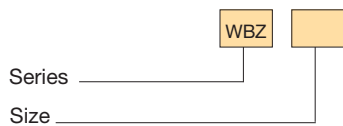

ORDER EXAMPLES

Piston rod locking unit, size 50 WBZ50
 Piston rod locking unit, size 80 + cylinder series “CPUi” Ø80, 150 mm stroke, fit for piston rod locking unit, non-magnetic piston type, ASSEMBLED: WBZ80 + 80/150 CPUi/NZ + M/WBZ

SPARE PARTS

BLADES KIT	Size/PM/WBZ
PISTON KIT	Size/SG/WBZ

WBZ PISTON ROD LOCKING UNIT

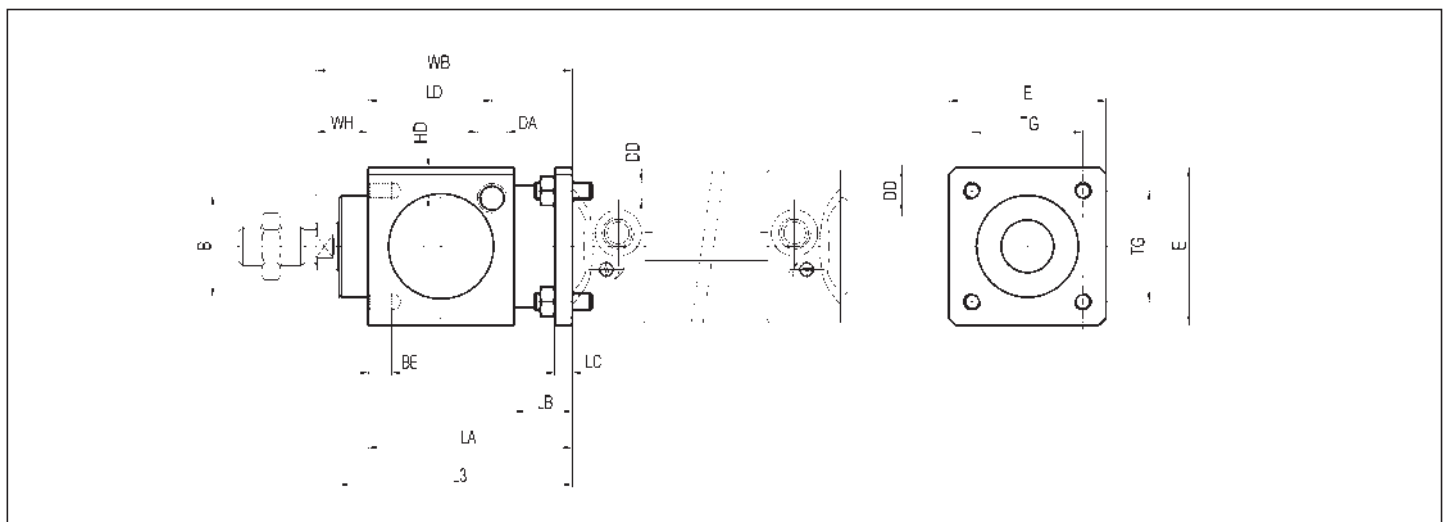

DIMENSIONS AND WEIGHTS

SIZE	B	BE	E	DA	DD	HD	L3	LA	LB	LC	LD	TG	WB	WH	WEIGHT (g)
32	30	8	47	G 1/8	M6	9	67,5	60	20	6	33,25	32,5	86	26	400
40	34,9	8	54	G 1/8	M6	9	80	70	20	6	42,5	38	100	30	600
50	40	12	65	G 1/8	M8	12,5	100	90	24	8	58	46,5	127	37	1100
63	45	12	75	G 1/8	M8	17,5	100	90	24	8	59	56,5	127	37	1500
80	45	16	95	G 1/4	M10	17,5	120	110	32	12	69	72	156	46	2600
100	55	16	114	G 1/4	M10	20	120	110	32	12	69	89	161	51	3500
125	60	20	138	G 1/4	M12	19	156	140	45	20	84,5	110	205	65	6500

P.S.: TECHNICAL INFORMATION (see the same ones for cylinders series “U” on page 1.7)

DESCRIPTION

Guide unit series "WUG" for cylinders to ISO 15552 standard (series "X" and "CPUI") act as devices against rotation of the piston rod in the presence of torques and they are used to carry out multi-axis systems where high movement precision is required.

Guide units are available in single and double version, and are supplied with self-lubricating bushings (for low speeds or heavy loads), or with recirculating ball bearing sleeves (for high speeds).

P.S.: Cylinders series "X" and "CPUI" (Ø 32 ÷ 63) in the magnetic version, assembled with these guide units, can accept respectively magnetic sensors types FM100 and FM157 only (see from page 1.93).

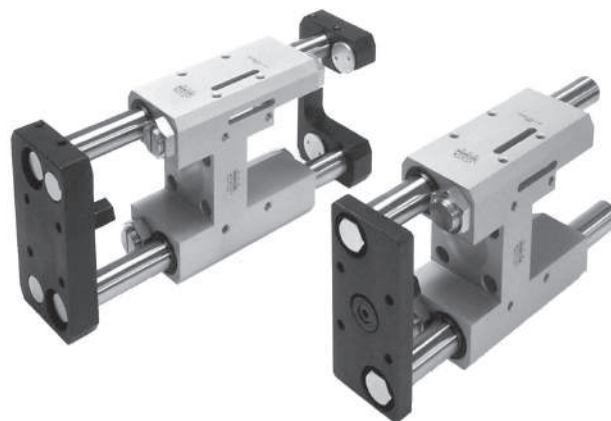

TECHNICAL DATA

Size	32, 40, 50, 63
Standard strokes (mm)	25, 50, 100, 150, 200, 250, 300, 350, 400, 500
Versions	Single unit Double unit

MATERIALS

Body	Anodized aluminium alloy
Self-aligning radial joint	Steel
Adjustable mechanical stop as standard	Brass
End flanges	Single unit: galvanized steel Double unit: anodized aluminium alloy
Guide bars	C45 chromium-plated steel (sliding type on bushings); Hardened steel (sliding type with sleeves)
Bushings	Self-lubricating sintered bronze with wiper ring
Sleeves	Recirculating ball bearings with wiper ring
Clamp	Brass

ORDER KEY

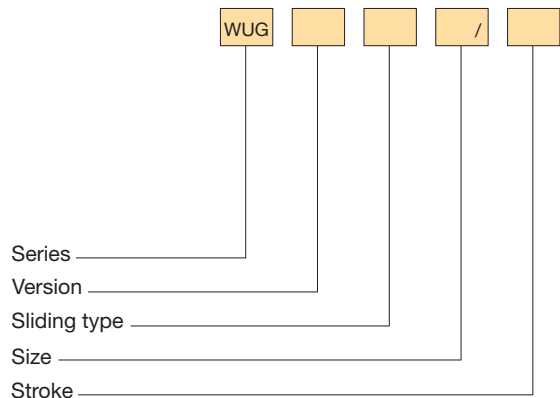

VERSION

Single unit _____ **D** Double unit

SLIDING TYPE

B On bushings _____ **M** With sleeves

ORDER EXAMPLES

Single guide unit, size 63, 150 mm stroke, with sleeves plus cylinder series "X" Ø 63, double acting, 150 mm stroke, magnetic piston type, ASSEMBLED

WUGM 63/150 + 63/150 X/M + M/WUG

Single guide unit, size 40, 250 mm stroke, with sleeves
 WUGM 40/250

Double guide unit, size 50, 100 mm stroke, with bushings
 WUGDB 50/100

ASSEMBLY

"WUG" + cylinders series "X" or "CPUI" _____ M/WUG

TECHNICAL INFORMATION

WUG SINGLE GUIDE UNIT

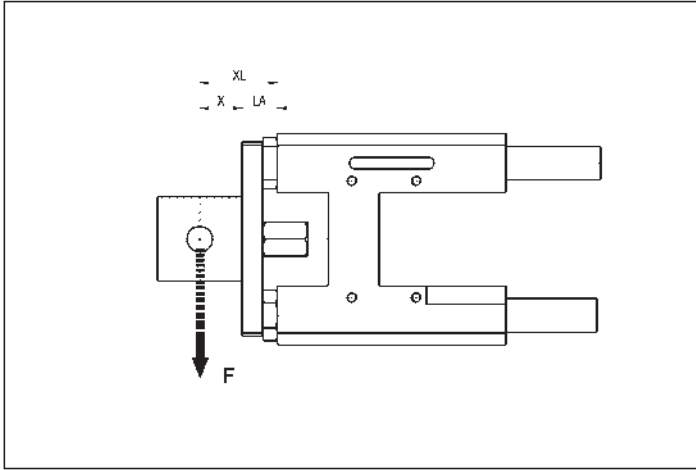

WUGD DOUBLE GUIDE UNIT

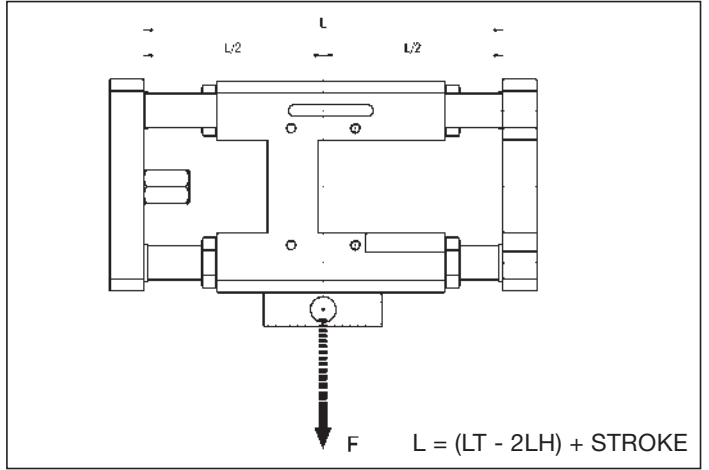

MAXIMUM PERMISSIBLE LOAD-WUG VERSION B

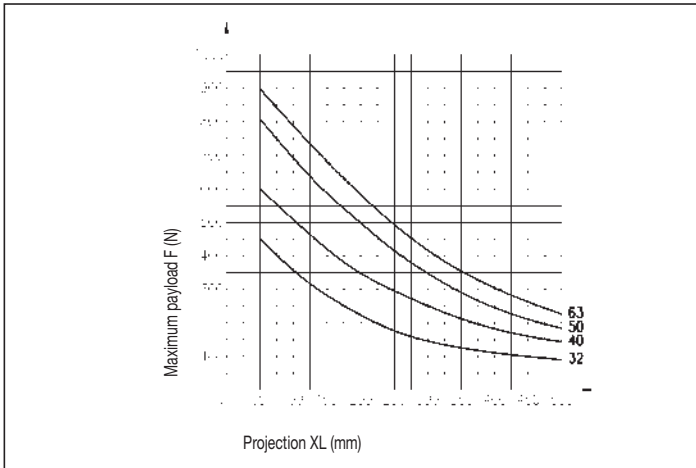

MAXIMUM PERMISSIBLE LOAD-WUGD VERSION B

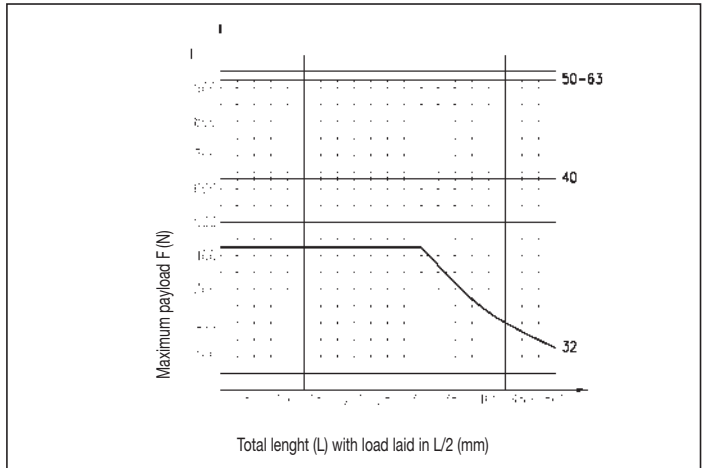

MAXIMUM PERMISSIBLE LOAD-WUG VERSION M

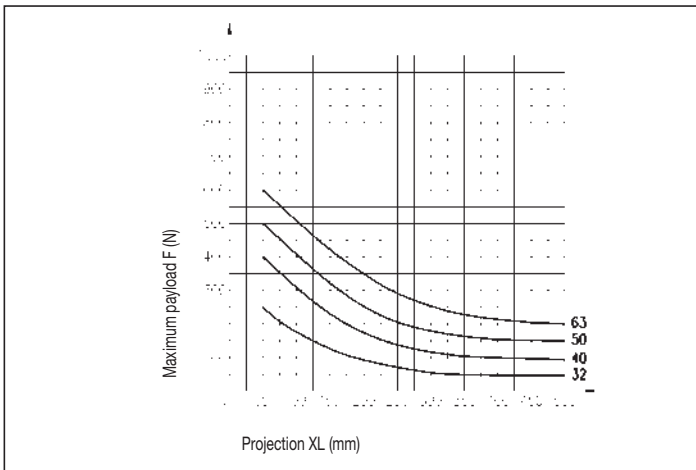

MAXIMUM PERMISSIBLE LOAD-WUGD VERSION M

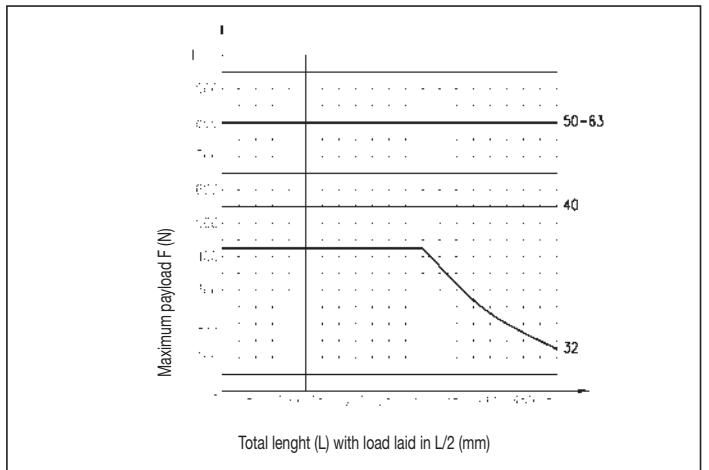

WUG SINGLE GUIDE UNIT

1

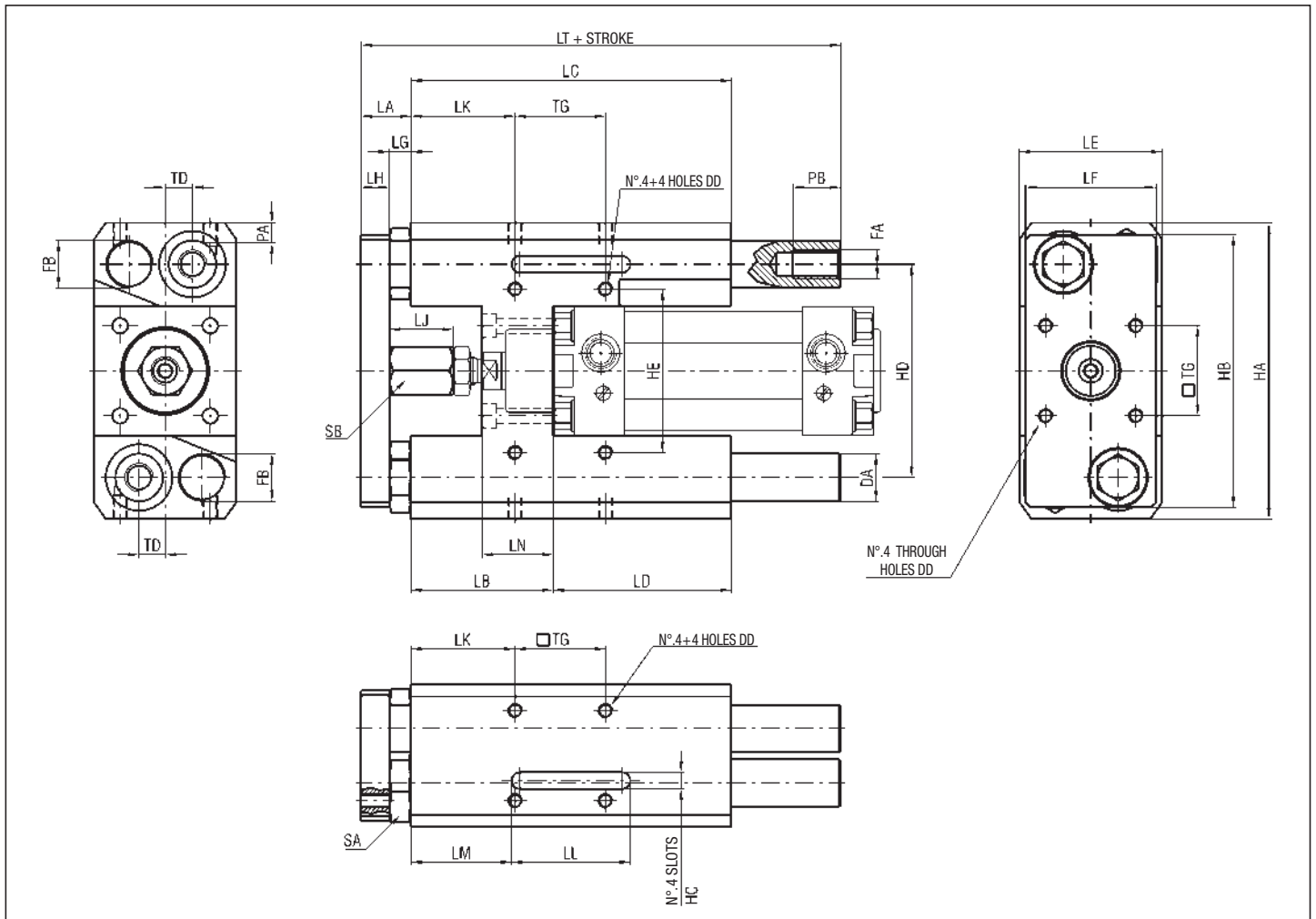

DIMENSIONS AND WEIGHTS

SIZE	DA	DD	FA	FB	HA	HB	HC	HD	HE	LA	LB	LC	LD	LE	LF	LG	LH
32	16	M6	M10x1,25	M18x1,5	112	100	7	79	61	20	50	120	70	50	45	8	12
40	20	M6	M12x1,25	M20x1,5	125	115	7	90	69	21	60	135	75	60	55	9	12
50	25	M8	M16x1,5	M24x2	150	144	7	108	85	25	70	150	80	70	65	10	15
63	25	M8	M16x1,5	M27x2	162	155	7	119	100	27	73	180	107	80	75	12	15

SIZE	LJ	LK	LL	LM	LN	LT	PA	PB	SA	SB	TD	TG	WEIGHT WUGB (g)	INCREM. (g) every 10 mm	WEIGHT WUGM (g)	INCREM. (g) every 10 mm
32	22	38	50	34,5	25	157	6	15	Ch.23	Ch.17	12	32,5	2060	29	1815	31
40	27	44	50	42,5	30	172	8	20	Ch.26	Ch.20	15	38	2905	45	2760	50
50	32	47	50	50	35	190	8	25	Ch.30	Ch.20	17,5	46,5	4780	65	4525	76
63	32	49,5	50	65	35	225	9,5	25	Ch.36	Ch.20	17	56,5	6315	65	5950	87

CLAMP FOR DECELERATOR - WUGCD SIZE

SIZE	FA	FB	L	WEIGHT (g)
32	M18x1,5	M12x1	40	50
40	M20x1,5	M14x1,5	45	60
50	M24x2	M16x1,5	50	105
63	M27x2	M20x1,5	60	130

CLAMP FOR MAGNETIC PROXIMITY SWITCH - WUGCP SIZE

SIZE	FA	FB	L	WEIGHT (g)
32	M18x1,5	M12x1	40	47
40	M20x1,5	M12x1	40	67
50	M24x2	M12x1	45	128
63	M27x2	M12x1	45	173

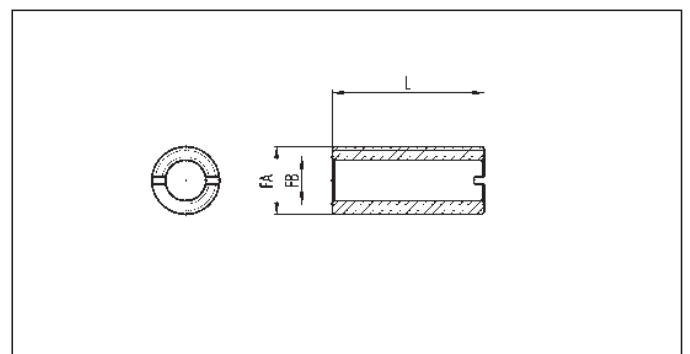

WUGD DOUBLE GUIDE UNIT

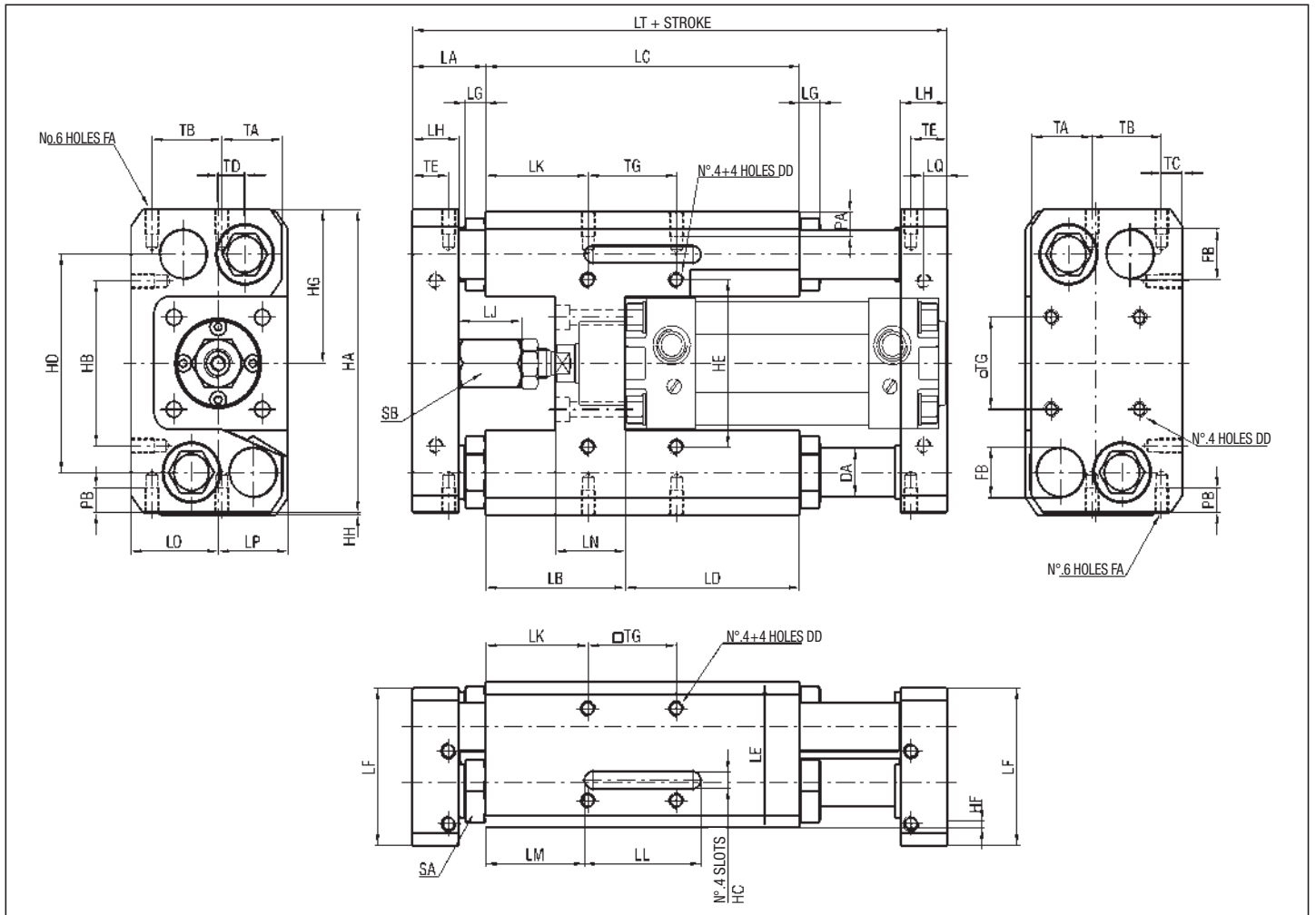

DIMENSIONS AND WEIGHTS

SIZE	DA	DD	FA	FB	HA	HB	HC	HD	HE	HF	HG	HH	LA	LB	LC	LD	LE
32	16	M6	M5	M18x1,5	112	60	7	79	61	1	57	1	28,5	50	120	70	50
40	20	M6	M6	M20x1,5	125	68	7	90	69	2,5	63,5	1	31,5	60	135	75	60
50	25	M8	M8	M24x2	150	79	7	108	85	1	76	1	37,5	70	150	80	70
63	25	M8	M8	M27x2	162	89	7	119	100	1	82	1	39,5	73	180	107	80

SIZE	LF	LG	LH	LJ	LK	LL	LM	LN	LO	LP	LQ	LT	PA	PB	SA	SB	TA
32	58	8	18	22	38	50	34,5	25	34	25	9	181	6	10	Ch.23	Ch.17	24
40	65	9	20	27	44	50	42,5	30	37,5	30	10	200	8	10	Ch.26	Ch.20	26
50	78,5	10	25	32	47	50	50	35	44,5	35	12,5	225	8	12	Ch.30	Ch.20	33,5
63	93	12	25	32	49,5	50	65	35	54	40	12,5	260	9,5	12	Ch.36	Ch.20	40

SIZE	TB	TC	TD	TE	TG	WEIGHT WUGDB (g) every 10 mm	INCREM. (g) every 10 mm	WEIGHT WUGDM (g) every 10 mm	INCREM. (g) every 10 mm
32	24,5	9,5	9,5	14	32,5	2320	29	2250	31
40	30	9	11,5	15,5	38	3480	45	3340	50
50	33	12	13	19	46,5	5750	65	5480	76
63	41	12	17	19	56,5	6445	65	6065	87

DESCRIPTION

Twin rod cylinders series "CPA" act as devices against rotation in the presence of torques. They have been designed to be interchangeable with cylinders that comply with ISO 15552 standard (series "X" and "CPU") and so they can be used with the standardized rear mountings of those cylinders. The cylinders series "CPA" are cushioned at both ends and with magnetic piston type as standard.



TECHNICAL DATA

Operating pressure	1 ÷ 10 bar
Working temperature	0 ÷ +80 °C (-20 °C with dry air)
Fluid	Filtered, unlubricated or continuous lubricated compressed air
Versions	Double acting; Through ISO rod
Bore	Ø 32, 40, 50, 63, 80, 100
Port size	Ø 32 = G 1/8 Ø 40 - 50 = G 1/4 Ø 63 - 80 = G 3/8 Ø 100 = G 1/2
Standard strokes (mm)	25, 50, 75, 80, 100, 125, 150, 160, 175, 200, 250, 300, 320, 350, 400, 500
Decelerators length	Ø 32 40 50 63 80 100 mm 25 25 25 30 35 35
Maximum strokes (mm)	Ø 32 - 40 = 200; Ø 50 - 63 = 350; Ø 80 - 100 = 500

MATERIALS

End caps	Anodized aluminium alloy
Cylinder barrel	Extruded profile, 20µm anodized aluminium alloy
Tie rods and nuts	Steel
Flange	Anodized aluminium alloy
Piston rod	C45 chromium-plated steel AISI 303 rolled stainless steel
Rod nut	Steel Stainless steel
Piston rod bearing	Bronze, sintered, self-lubricating
Decelerators ogives	Aluminium alloy
Piston	Aluminium alloy, Derling with magnet
Seals	Polyurethane

ORDER KEY

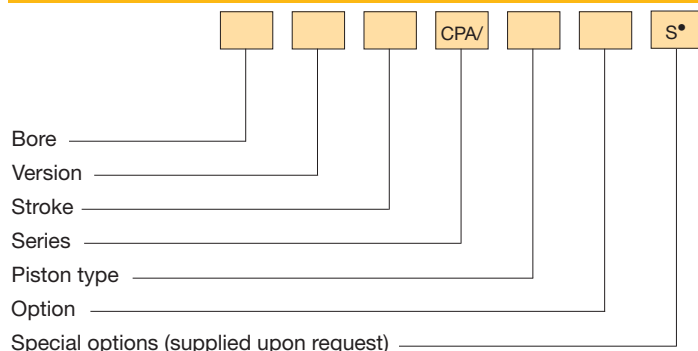

P.S.: Magnetic sensors FM100-FM157-FM158 (see chapter magnetic sensors from page 1.93)
 • See technical data on page 0.12

VERSION

/ Double acting **RA** Through ISO rod

PISTON TYPE

- **M** Magnetic

OPTION

1 Stainless steel piston rods and rod nut

SPARE PARTS

SEALS KIT	
Polyurethane	Ø/SG/CPA/M
Through ISO rod, polyurethane	Ø/SG/RA/CPA/M

TECHNICAL INFORMATION

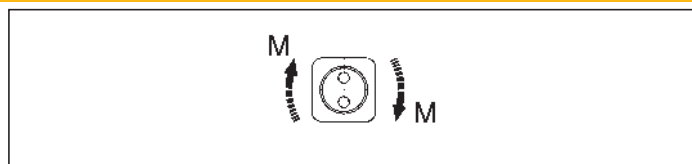
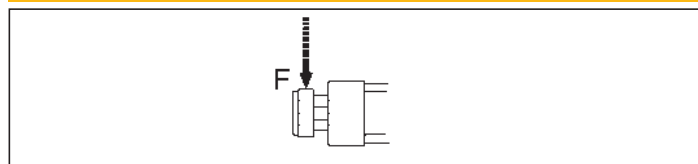

MAXIMUM PERMISSIBLE TRANSVERSE FORCE

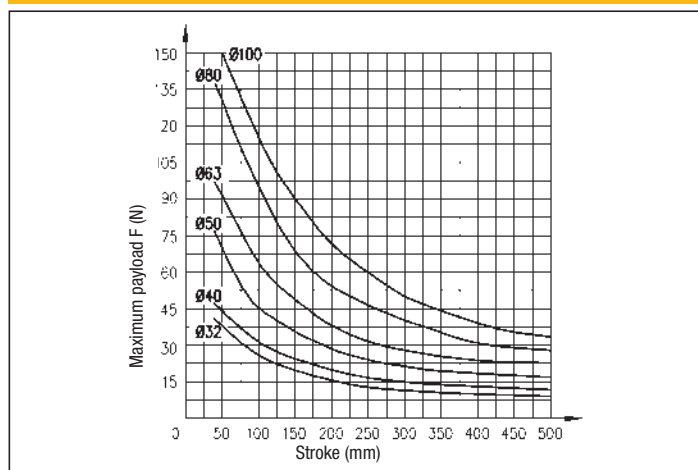

MAXIMUM PERMISSIBLE TORQUE

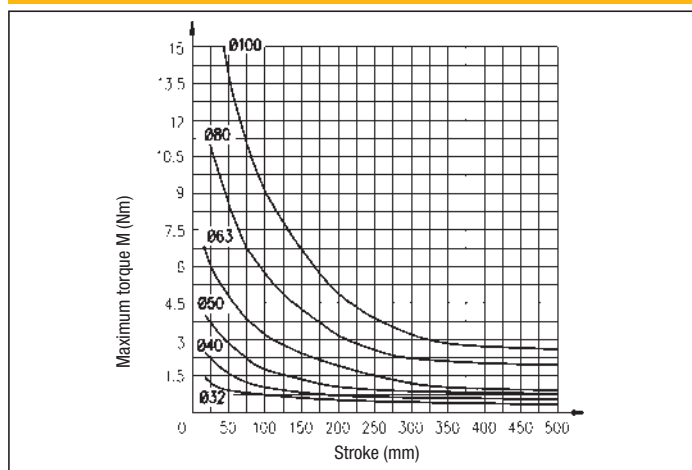

CPA BASIC CYLINDER

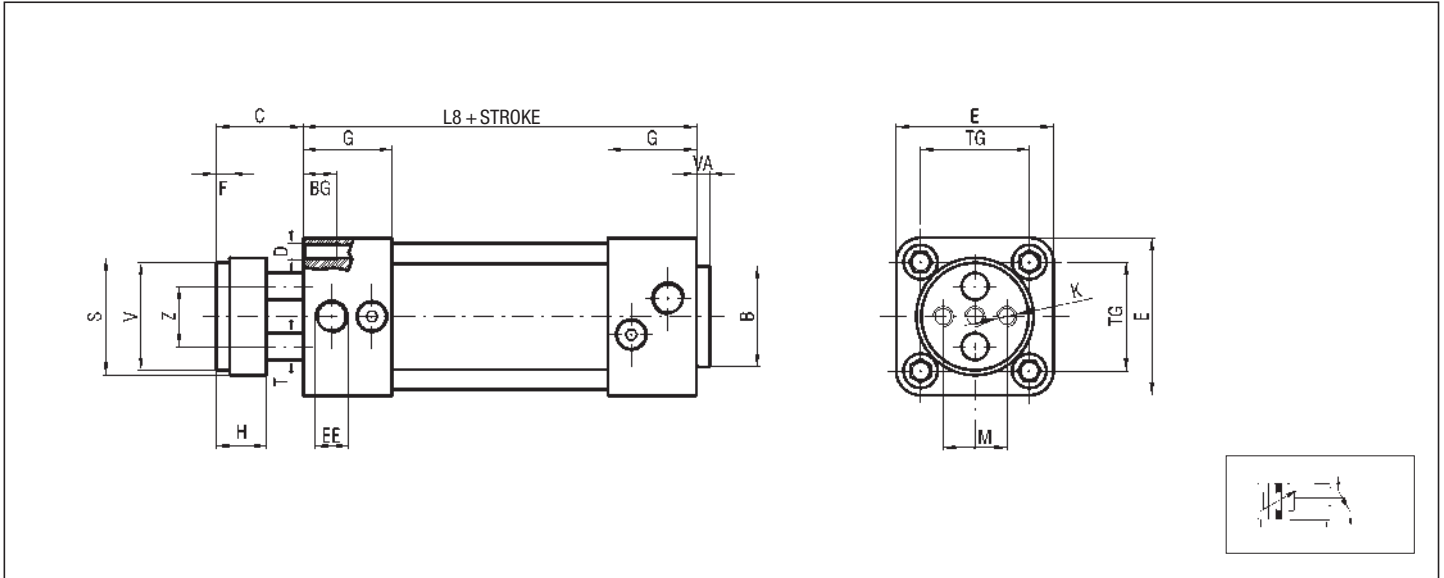

DIMENSIONS AND WEIGHTS BASIC CYLINDER

Ø	B	BG	C	D	E	EE	F	F1	G	H	K	L8	M	S	T	TG	V	VA	Z	WEIGHT (g)	INCR. (g) x 10 mm
32	30	16	26	M6	47	G1/8	4	48	28	15	M6	94	19	35	8	32,5	32	4	18	770	30
40	35	16	30	M6	53	G1/4	4	54	31,5	15	M8	105	22,5	45	10	38	40	4	22	980	43
50	40	16	37	M8	65	G1/4	5	69	31,5	18	M8	106	30	55	12	46,5	50	4	26	1570	70
63	45	16	37	M8	75	G3/8	5	69	35	22	M10	121	38	70	16	56,5	63	4	35	2320	128
80	45	16	46	M10	95	G3/8	5	86	36	22	M12	128	50	85	20	72	80	4	40	3830	132
100	55	16	51	M10	115	G1/2	5	91	41	22	M12	138	70	105	20	89	100	4	50	5600	139

THROUGH ISO ROD

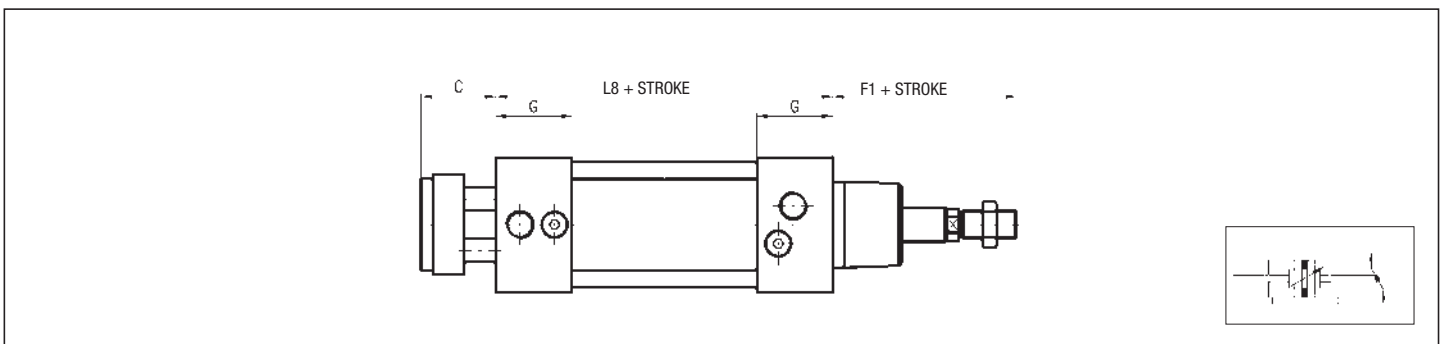

P.S.: Rod nut supplied as standard

1

FLANGE - STEEL - Ø 32 ÷ 50 - CPUI/F Ø
(Supplied with screws) - Ø 63 ÷ 100 - CPA/F Ø

Ø	FB H13	E	MF JS14	R JS14	TF JS14	UF	W
32	7	45	10	32	64	80	16
40	9	52	10	36	72	90	20
50	9	65	12	45	90	110	25
63	9	75	12	50	100	120	25
80	12	95	16	63	126	150	30
100	14	115	16	75	150	170	35

Ø	ZF	WEIGHT (g)
32	130	190
40	145	246
50	155	478
63	170	622
80	190	1430
100	205	1986

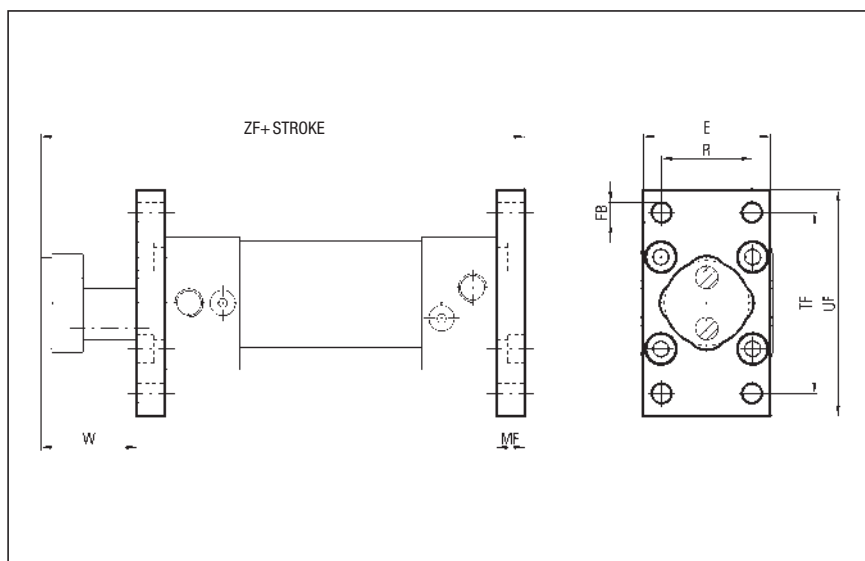

FOOT - STEEL - Ø 32 ÷ 50 - CPUI/PB Ø
(Supplied with screws) - Ø 63 ÷ 100 - CPA/PB Ø

Ø	AB H14	AH JS15	AT	AU	E	F	SA
32	7	32	4	24	45	35	142
40	9	36	4	28	52	36	161
50	9	45	5	32	65	47	170
63	9	50	5	32	75	45	185
80	12	63	6	41	95	55	210
100	14	71	6	41	115	57	220

Ø	SB	TR JS14	WEIGHT (g)
32	144	32	66
40	163	36	78
50	175	45	168
63	190	50	190
80	215	63	382
100	230	75	452

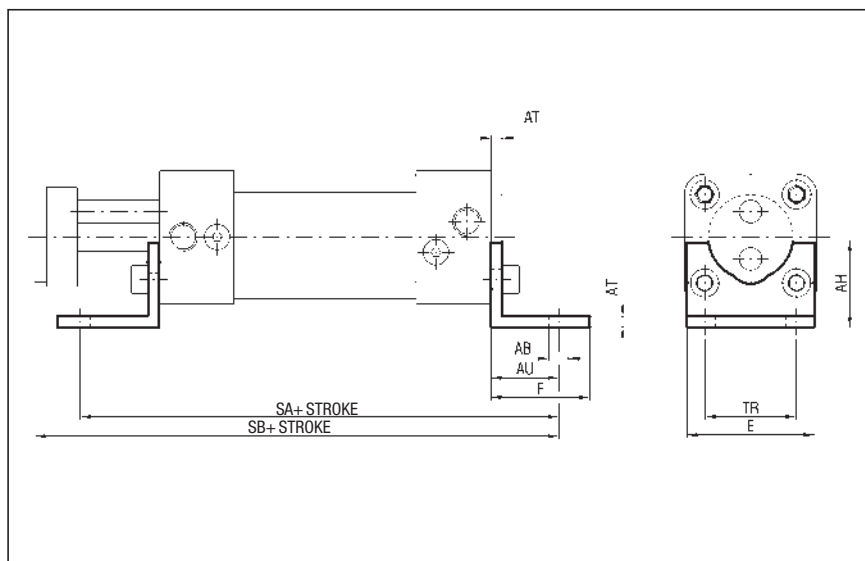

P.S.: REAR MOUNTINGS ACCESSORIES SAME OF THE CYLINDERS SERIES "X" AND "CPUI" (see from page 1.29)

Cylinders to AFNOR NF E49-001 (ex CNOMO) standard

series CX

1

DESCRIPTION

Cylinders series "CX" comply with AFNOR NF E49-001 (ex CNOMO) standard and so they result interchangeable.
Cylinders series "CX" with magnetic piston type can be supplied with magnetic sensors.



TECHNICAL DATA

Operating pressure	1 ÷ 10 bar
Working temperature	0 ÷ +80 °C (-20 °C with dry air) 0 ÷ +150 °C with seals for high temperatures (-20 °C with dry air)
Fluid	Filtered, unlubricated or continuous lubricated compressed air
Versions	Double acting; Single acting front spring; Single acting rear spring; Through rod; Double push tandem; Double stroke tandem; Opposed tandem
Bore	Ø 32, 40, 50, 63, 80, 100, 125, 160, 200
Port size	Ø 32 = G 1/8 Ø 40 - 50 = G 1/4 Ø 63 - 80 = G 3/8 Ø 100 - 125 = G 1/2 Ø 160 - 200 = G 3/4
Standard strokes (mm)	25, 50, 75, 100, 125, 150, 200, 250, 300, 350, 400, 500, 600, 700, 800, 900, 1000
Decelerators length	Ø 32 40 50 63 80 100 125 160 200 mm 25 30 30 35 35 40 40 50 50
Maximum strokes (mm)	Ø 32 ÷ 200 = 3000
Max. strokes single acting (mm)	Ø 32 ÷ 100 = 50

MATERIALS

End caps	Anodized aluminium alloy
Cylinder barrel	Extruded tube, anodized aluminium alloy
Tie rods, tie and rod nuts	Steel Stainless steel (supplied upon request for tie rods and tie nuts)
Piston rod	C45 chromium-plated steel AISI 303 rolled stainless steel
Piston rod bearing	Bronze-iron 20%, sintered, self-lubricating
Decelerators ogives	Aluminium alloy
Piston	NBR rubber block (supplied with and without magnet) Viton® (supplied only with non-magnetic piston type)
Seals	NBR rubber Viton®

ORDER KEY

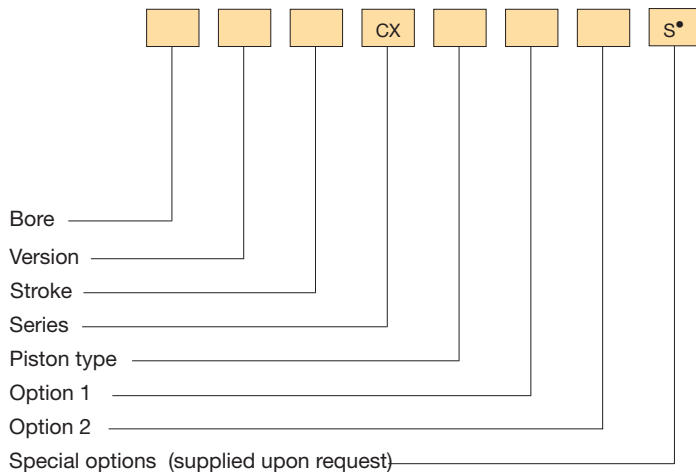

P.S.: *Magnetic sensors* FM 100 - FM157 - FM158 (see chapter magnetic sensors from page 1.93)
• See technical data on page 0.12

VERSION

/	Double acting	T	Double push tandem
S	Single acting front spring	P	Double stroke tandem
Y	Single acting rear spring	V	Opposed tandem
R	Through rod		

PISTON TYPE

Non-magnetic /FM Magnetic

OPTION 1

1	Stainless steel piston rod and rod nut	3	Stainless steel piston rod and rod nut and seals for high temperatures*
2	Seals for high temperatures**		

OPTION 2

4	Brass cylinder barrel**	6	Inner chromium-plated steel cylinder barrel**
---	-------------------------	---	---

* Supplied only with non-magnetic piston type
** Supplied from Ø 32 to Ø 100

ORDER EXAMPLES

Cylinder Ø50, double acting, 100 mm stroke, non-magnetic piston type 50/100 CX

Cylinder Ø63, through rod, 150 mm stroke, magnetic piston type, stainless steel piston rod 63R150 CX/FM1

Cylinder Ø80, double push tandem, 50 mm stroke, magnetic piston type 80T50 CX/FM

Cylinder Ø80, double stroke tandem, 50 mm stroke 1 + 100 mm stroke 2, magnetic piston type 80P50+100 CX/FM

Cylinder Ø80, opposed tandem, 50 mm stroke 1 + 50 mm stroke 2, magnetic piston type, brass cylinder barrel 80V50+50 CX/FM4

SPARE PARTS

SEALS KIT		
Non-magnetic piston type	NBR	Ø/SG/CX
	Through rod, NBR	Ø/SG/R/CX
	For high temperatures	Ø/SG/CX2
	Through rod, for high temperatures	Ø/SG/R/CX2
Magnetic piston type	NBR	Ø/SG/CX/FM
	Through rod, NBR	Ø/SG/R/CX/FM

CX BASIC CYLINDER

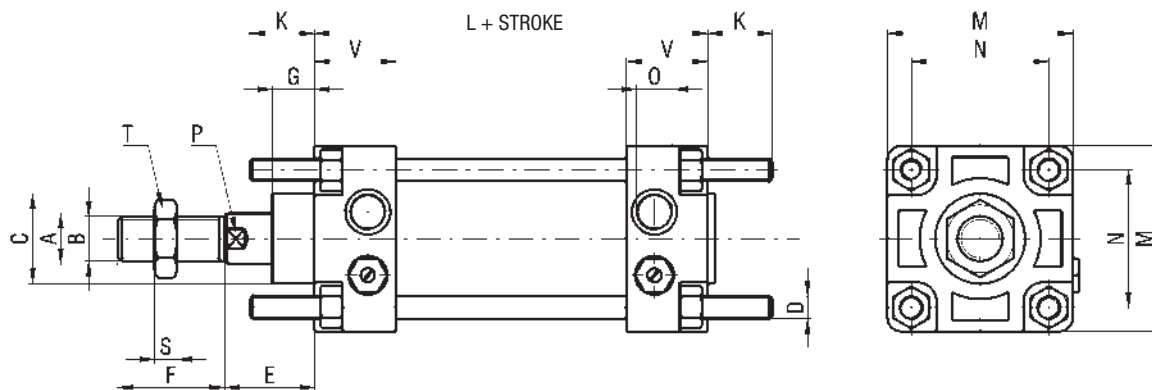

P.S.: Rod nut supplied as standard

DIMENSIONS AND WEIGHTS BASIC CYLINDER

Ø	A	B	C	D	E	F	G	H	K	L	L1	M	N	O	P	R	S	T	V	WEIGHT (g)	INCREMENT (g) every 10 mm
32	12	M10	25	M6	25	20	15	134	17	80	90	45	33	G 1/8	10	7	5	17	26	482	23
40	18	M16x1,5	32	M6	34	36	15	191	17	110	129	52	40	G 1/4	16	7	8	24	29	907	35
50	18	M16x1,5	32	M8	34	36	15	191	23	110	129	65	49	G 1/4	16	7	8	24	29	1170	46
63	22	M20x1,5	45	M8	39	46	20	216	23	125	143	75	59	G 3/8	20	9	10	30	34	1817	59
80	22	M20x1,5	45	M10	39	46	20	215	28	125	143	95	75	G 3/8	20	9	10	30	35	2680	66
100	30	M27x2	55	M10	47	63	20	251	28	145	164	115	90	G 1/2	27	9	13,5	41	39	4422	93
125	30	M27x2	55	M12	47	63	20	248	34	145	164	140	110	G 1/2	27	9	13,5	41	42	6630	110
160	40	M36x2	65	M16	50	85	25	310	42	180	200	180	140	G 3/4	36	13	18	55	50	13820	210
200	40	M36x2	65	M16	50	85	25	310	42	180	200	220	175	G 3/4	36	13	18	55	50	18840	290

THROUGH ROD

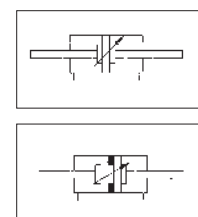
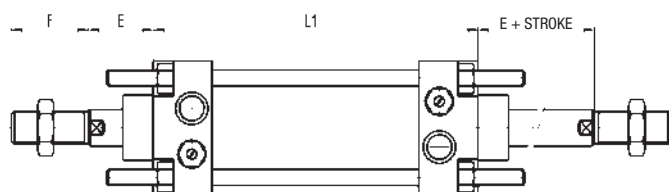

P.S.: Rod nuts supplied as standard

DOUBLE PUSH TANDEM

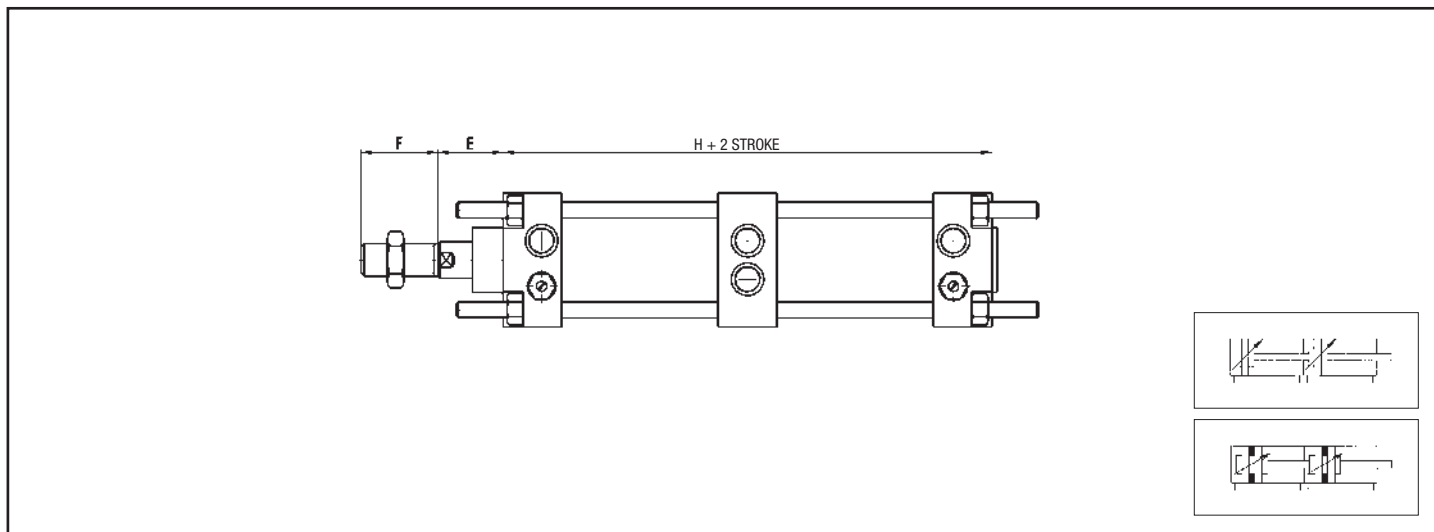

P.S.: Rod nut supplied as standard

DOUBLE STROKE TANDEM

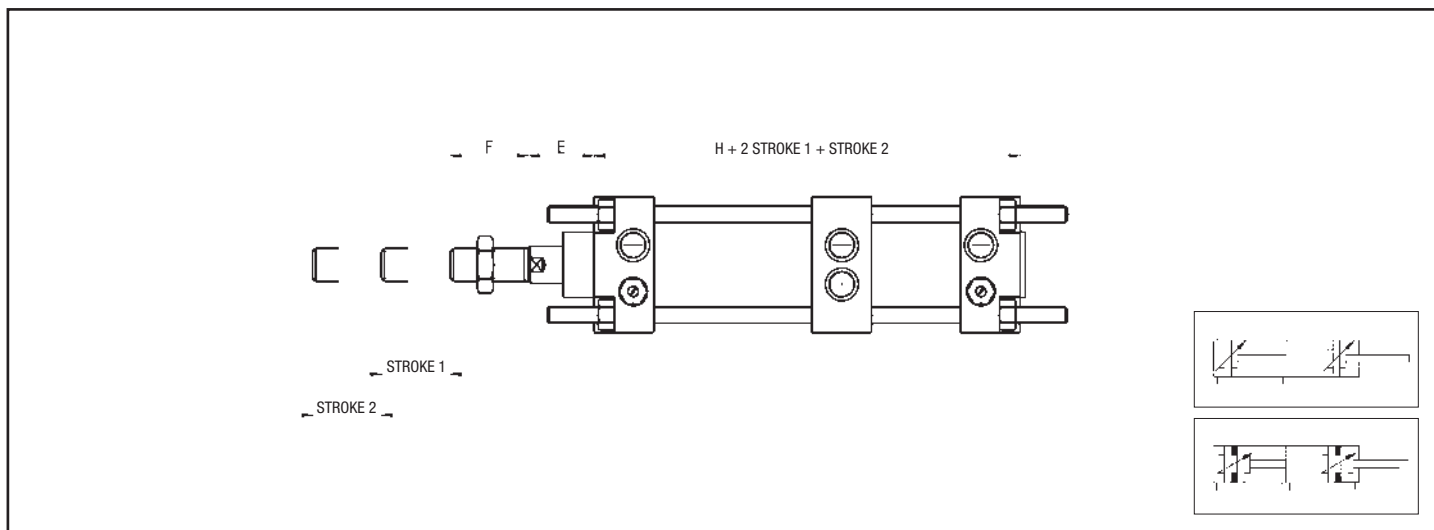

P.S.: Rod nut supplied as standard

OPPOSED TANDEM

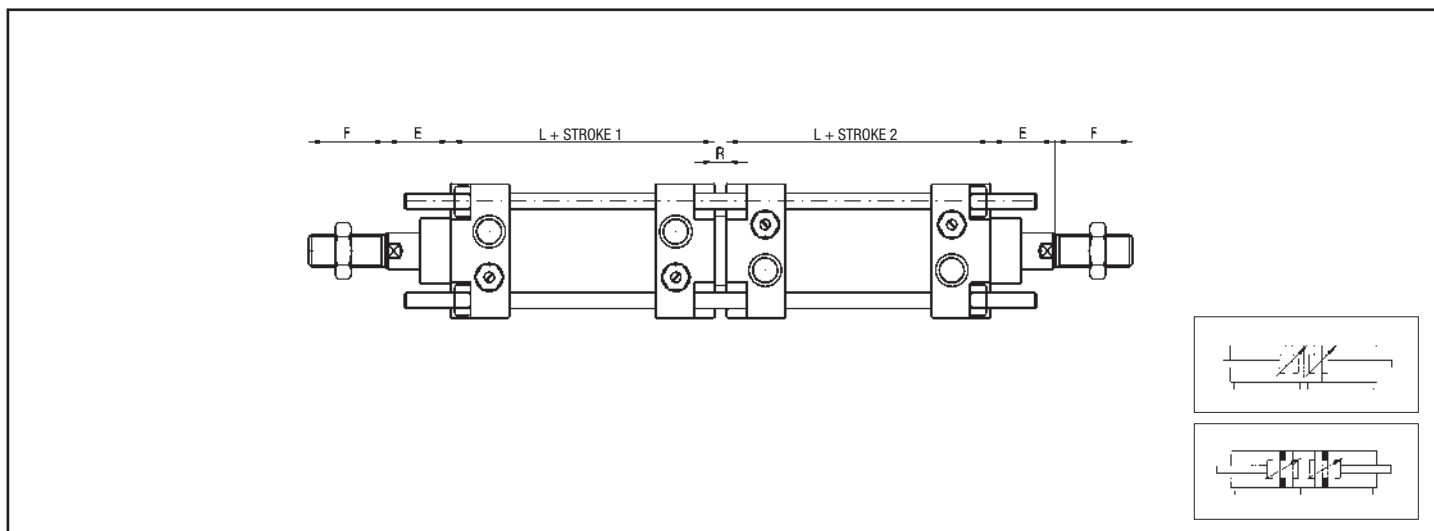

P.S.: Rod nuts supplied as standard

1

FLANGE - STEEL - CX/F Ø

Ø	A	B	D H13	E	G	LE	LF
32	68	80	9	33	8	17	113
40	78	90	9	40	8	26	152
50	94	110	11	49	10	24	154
63	104	120	11	59	10	29	174
80	130	150	14	75	12	27	176
100	150	170	14	90	12	35	204
125	180	205	18	110	16	31	208
160	228	260	22	140	20	30	250
200	268	300	22	170	20	30	250

Ø	M	WEIGHT (g)
32	45	158
40	52	206
50	65	424
63	75	504
80	95	1046
100	115	1480
125	140	3000
160	180	6300
200	220	9300

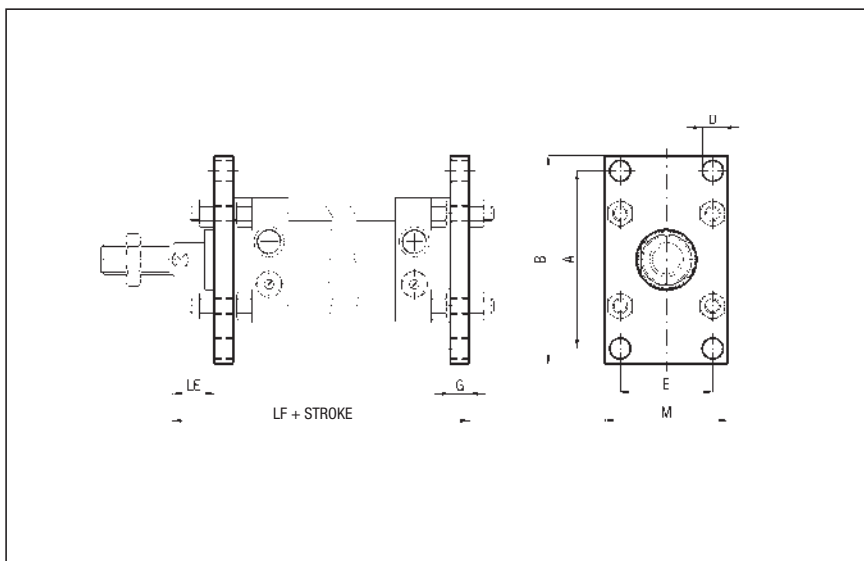

HIGH FOOT - ALUMINIUM - CX/P Ø

Ø	A	D H13	F	G	H	LA	LW
32	28	9	32	8	35	134	132
40	36	9	36	8	35	164	171
50	45	11	45	10	45	180	179
63	55	11	50	10	45	195	199
80	70	14	63	12	55	211	207
100	90	14	73	12	55	231	235
125	100	18	91	16	68	249	244
160	130	22	115	20	82	304	292
200	170	22	135	20	92	304	292

Ø	M	O	WEIGHT (g)
32	45	27	54
40	52	27	70
50	65	35	150
63	75	35	170
80	95	43	354
100	115	43	470
125	140	52	918
160	180	62	2300
200	220	62	3450

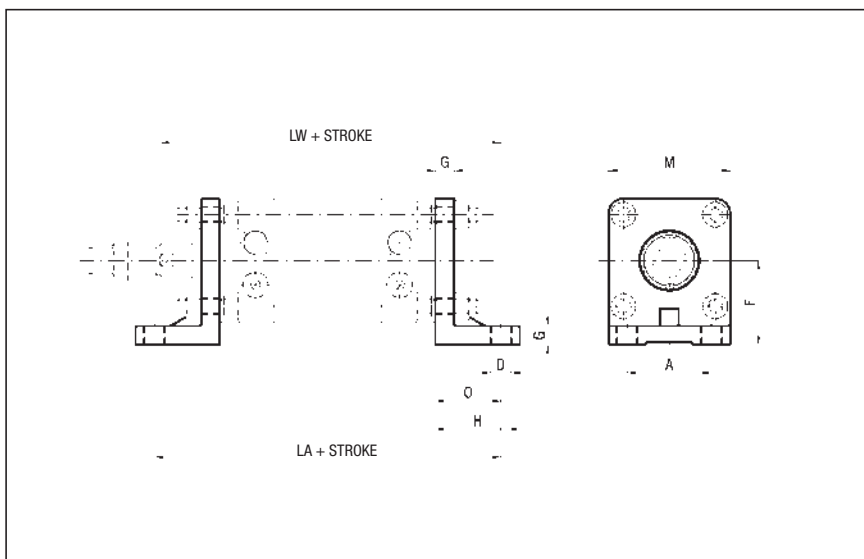

LARGE HIGH FOOT - ALUMINIUM - CX/PL Ø

Ø	A	B	D H13	F	G	H	LC
32	65	82	9	32	8	35	116
40	72	90	9	36	8	35	146
50	90	110	11	45	10	45	154
63	100	120	11	50	10	45	169
80	126	154	14	63	12	55	181
100	148	180	14	73	12	55	201
125	180	216	18	91	16	67,5	209
160	230	275	22	115	20	80	260
200	270	318	22	135	20	80	260

Ø	LD	LP	LQ	M	O	P	WEIGHT (g)
32	60	95	123	45	18	54,5	76
40	90	134	162	52	18	62	90
50	86	132	166	65	22	77,5	188
63	101	152	186	75	22	87,5	206
80	93	148	192	95	28	110	410
100	113	176	220	115	28	130	576
125	113	176	224	140	32	161	1058
160	140	210	270	180	40	206	2350
200	140	210	270	220	40	246	3100

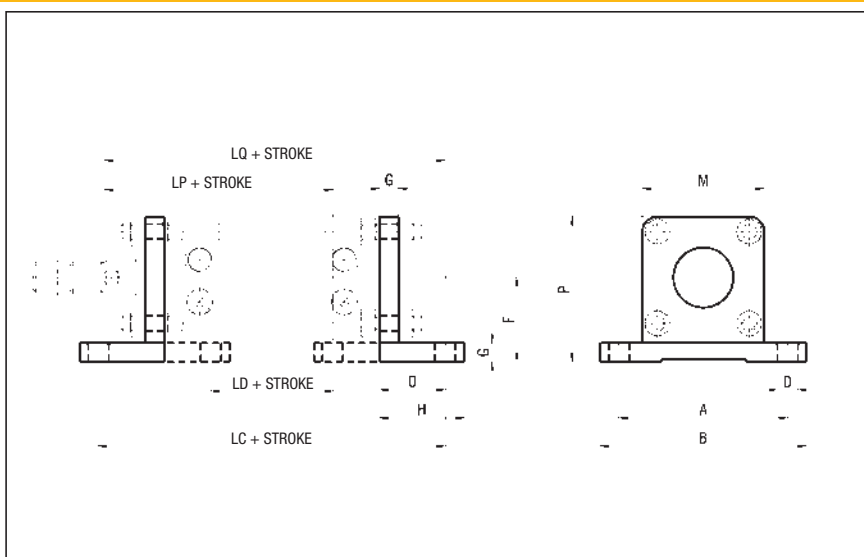

LOW FOOT - STEEL - CX/PB Ø

Ø	A	D	E	F	H	LA	LW
32	28	45	15,5	32	35	134	132
40	36	52	16	36	36	164	171
50	45	65	20,5	45	45	180	179
63	55	75	20,5	50	45	195	199
80	70	95	25,5	63	55	211	207
100	90	115	27	73	56	231	235
125	100	140	36	91	70	249	244
160	130	180	45	115	75	304	292
200	170	220	47	135	100	304	292

Ø	M H13	O	S	WEIGHT (g)
32	4,5	27	4	66
40	4,5	27	4	78
50	5,5	35	5	168
63	5,5	35	5	190
80	7	43	6	382
100	7	43	6	452
125	9	52	8	1090
160	11	62	10	1180
200	11	62	12	3450

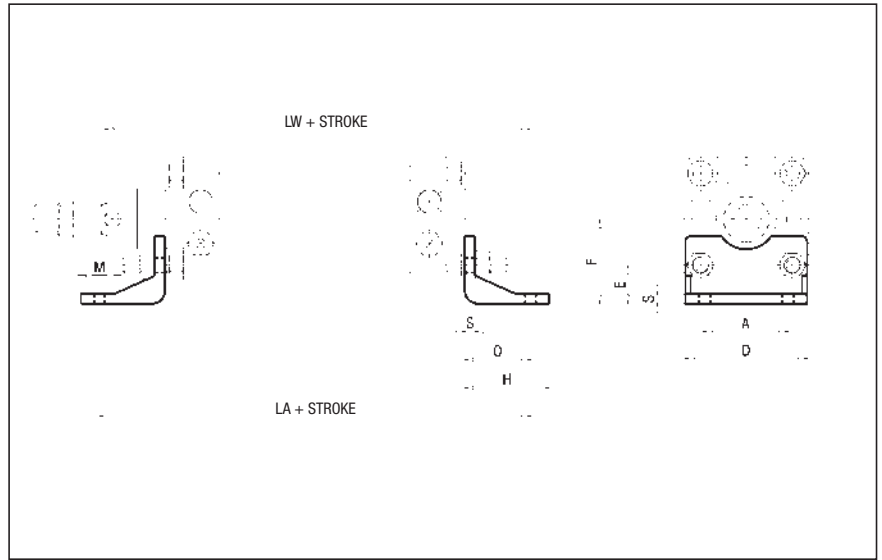

FEMALE HINGE - ALUMINIUM - CX/CF Ø

Ø	G	K	LY	M	O	R	S H9
32	8	18	123	45	26	8	8
40	8	24	168	52	33	12	12
50	10	26	170	65	33	12	12
63	10	30	194	75	47	16	16
80	12	32	196	95	47	16	16
100	12	37	229	115	57	20	20
125	16	41	233	140	57	21	20
160	20	55	285	180	72	25	25
200	20	55	285	220	72	25	25

Ø	WEIGHT (g)
32	38
40	58
50	118
63	146
80	324
100	492
125	978
160	1872
200	2800

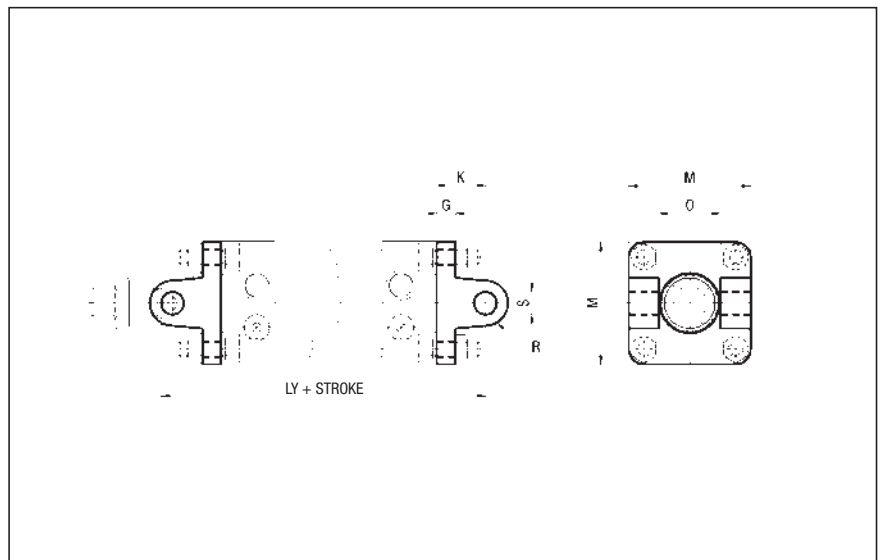

PIVOT FOR REAR FEMALE HINGE - STEEL - CX/SEC Ø

Ø	EK f7	EL	BU	WEIGHT (g)
32	8	46	53	21
40	12	53	60	52
50	12	66	73	64
63	16	76	83	130
80	16	96	103	160
100	20	117	124	304
125	20	142	149	364
160	25	182	189	720
200	25	222	229	872

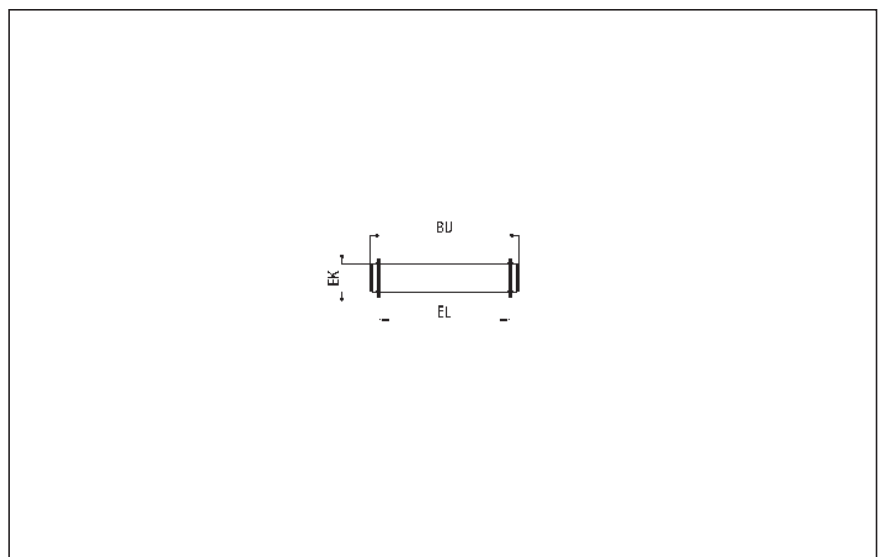

1

NORMAL ARTICULATED JOINT - ALUMINIUM - CX/AN Ø

Ø	A	B	D	E	F	H	LY
32	25	0	40	28	7	26	123
40	32	16	52	38	9	38	168
50	32	16	52	38	9	38	170
63	46	25	75	54	11	52	194
80	46	25	75	54	11	52	196
100	56	32	115	90	14	61	229
125	56	32	115	90	14	61	233
160	71	43	180	150	18	80	285
200	71	43	180	150	18	80	285

Ø	P	S H9	T	WEIGHT (g)
32	18	8	8	26
40	26	12	10	56
50	26	12	10	56
63	34	16	12	176
80	34	16	12	176
100	41	20	16	376
125	41	20	16	376
160	55	25	20	924
200	55	25	20	924

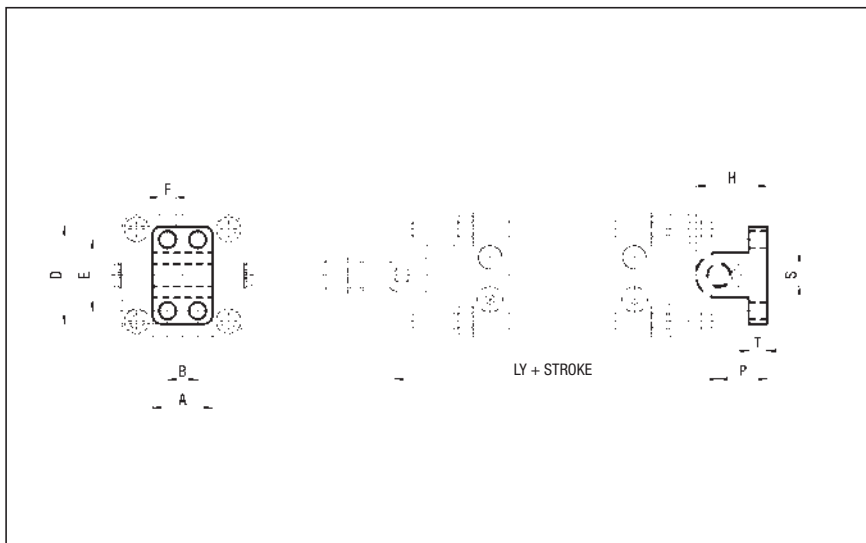

SQUARE JOINT - ALUMINIUM - CX/AS Ø/SQ

Ø	A	B	BG	D	F H13	H	LY
32	25	25	20	37	7	18	123
40	32	32	32	54	9	25	168
50	32	32	32	54	9	25	170
63	46	40	50	75	11	32	194
80	46	40	50	75	11	32	196
100	56	50	70	103	14	40	229
125	56	50	70	103	14	40	233
160	70	63	110	154	18	50	285
200	70	63	110	154	18	50	285

Ø	P	R	S H9	T	V	WEIGHT (g)
32	32	19,5	8	8	41	58
40	45	26	12	10	52	144
50	45	26	12	10	52	144
63	63	32	16	13	63	300
80	63	32	16	13	63	300
100	90	42	20	17	80	649
125	90	42	20	17	80	649
160	140	54	25	20	111	1922
200	140	54	25	20	111	1922

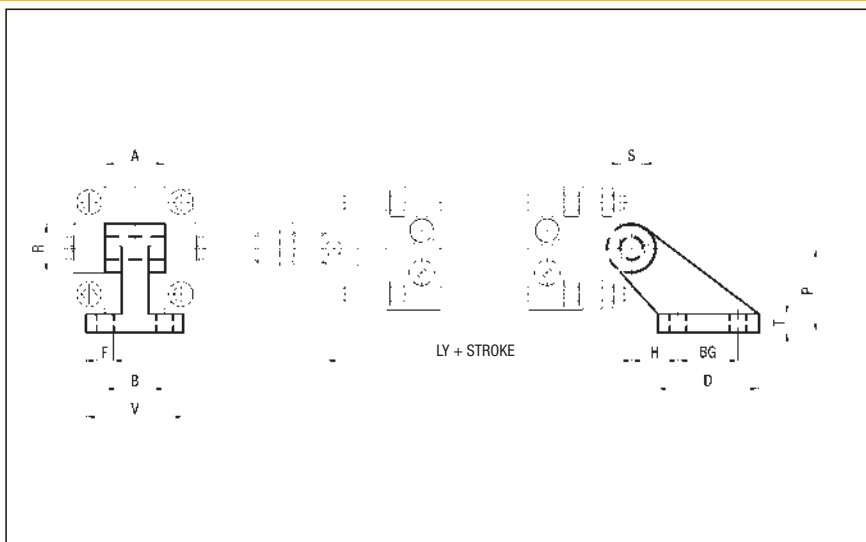

INTERMEDIATE HINGE - Ø 32 ÷ 100 - STEEL - CX/CPU/CT Ø (Supplied with dowels) - Ø 125 ÷ 200 - STEEL - CX/CPU/CT Ø

Ø	A	B h14	D e9	E h14	G	M	Q min
32	46	50	12	12	15	6,25	58,5
40	59	63	16	16	20	6,25	73
50	69	73	16	16	20	8,25	73
63	84	90	20	20	25	8,25	85,5
80	102	108	20	20	25	10,25	86,5
100	125	131	25	25	30	10,25	101
125	155	160	25	25	32	12,25	105
160	190	200	32	32	40	16,25	120
200	240	250	32	32	40	16,25	120

Ø	Q max	WEIGHT (g)
32	71,5	130
40	105	306
50	105	370
63	117,5	702
80	116,5	894
100	138	1590
125	134	2600
160	160	4300
200	160	7450

P.S.:
- ADJUSTABLE POSITION (fixing through dowels)
ASSEMBLY:
CX/CPU/CT Ø + cylinder CX type M/CX/CPU/CT Ø
- FIXED POSITION
(specify dimension "Q"; fixed on cylinder with completed threaded and galvanized tie rods type "S6", see on page 0.12)
ASSEMBLY:
CX/CPU/CT Ø or CX/CPU/CT Ø
+ cylinder CX S6 type MF/CX/CPU/CT Ø

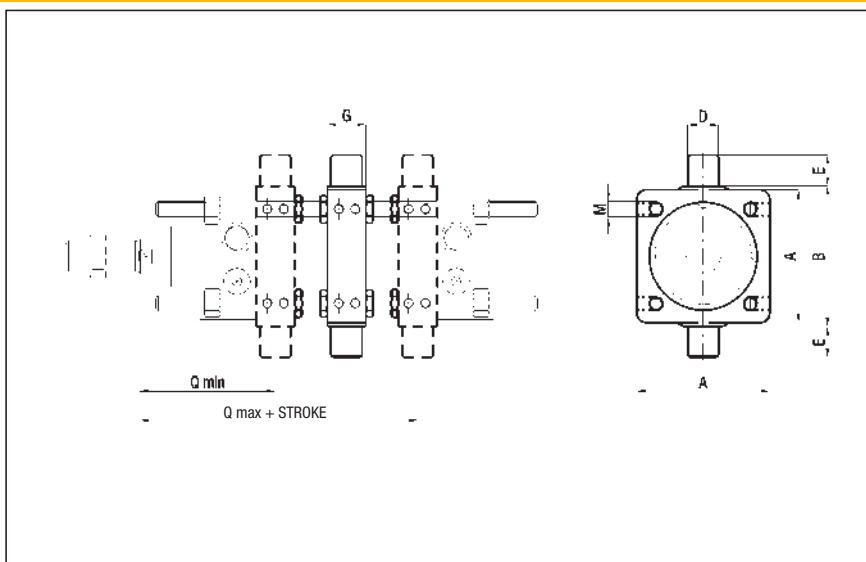

Cylinders to ex CETOP RP 43 P standard

series CPU

DESCRIPTION

Cylinders series "CPU" comply with ex CETOP RP 43 P standard. The versions with magnetic piston type can be supplied with magnetic sensors.



1

TECHNICAL DATA

Operating pressure	1 ÷ 10 bar
Working temperature	0 ÷ +80 °C (-20 °C with dry air) 0 ÷ +150 °C with seals for high temperatures (-10 °C with dry air)
Fluid	Filtered, unlubricated or continuous lubricated compressed air
Versions	Double acting; Single acting front spring; Single acting rear spring; Through rod
Bore	Ø 32, 40, 50, 63, 80, 100
Port size	Ø 32 = G 1/8 Ø 40 - 50 = G 1/4 Ø 63 - 80 = G 3/8 Ø 100 = G 1/2
Standard strokes (mm)	25, 50, 75, 100, 125, 150, 200, 250, 300, 350, 400, 500, 600, 700, 800, 900, 1000
Decelerators length	Ø 32 40 50 63 80 100 mm 25 30 30 35 35 40
Maximum strokes (mm)	Ø 32 ÷ 100 = 3000
Max. strokes single acting (mm)	Ø 32 ÷ 100 = 50

MATERIALS

End caps	Anodized aluminium alloy
Cylinder barrel	Extruded tube, anodized aluminium alloy
Tie rods, tie and rod nuts	Steel Stainless steel (supplied upon request for tie rods and tie nuts)
Piston rod	C45 chromium-plated steel AISI 303 rolled stainless steel
Piston rod bearing	Bronze-iron 20%, sintered, self-lubricating
Decelerators ogives	Aluminium alloy
Piston	NBR rubber block (supplied with and without magnet) Viton® (supplied only with non-magnetic piston)
Seals	NBR rubber Viton®

ORDER KEY

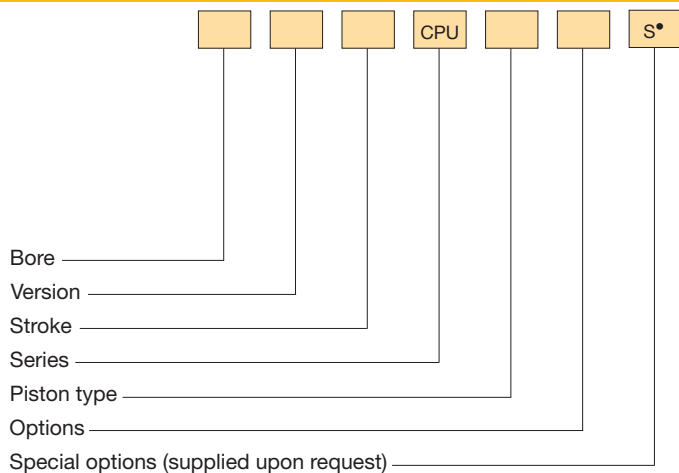

VERSION

/	Double acting	Y	Single acting rear spring
S	Single acting front spring	R	Through rod

PISTON TYPE

Non-magnetic	/FM	Magnetic
--------------	-----	----------

OPTIONS

1	Stainless steel piston rod and rod nut	3	Stainless steel piston rod and rod nut and seals for high temperatures*
2	Seals for high temperatures*		

* Supplied only with non-magnetic piston type

P.S.: *Magnetic sensors* FM 100 - FM157 - FM158 (see chapter magnetic sensors from page 1.93)

• See technical data on page 0.12

ORDER EXAMPLES

Cylinder Ø50, double acting, 100 mm stroke, non-magnetic piston type 50/100 CPU

Cylinder Ø63, through rod, 150 mm stroke, magnetic piston type, stainless steel piston rod 63R150 CPU/FM1

SPARE PARTS

SEALS KIT		
Non-magnetic piston type	NBR	Ø/SG/CPU
	Through rod, NBR	Ø/SG/R/CPU
	For high temperatures	Ø/SG/CPU2
	Through rod, for high temperatures	Ø/SG/R/CPU2
Magnetic piston type	NBR	Ø/SG/CPU/FM
	Through rod, NBR	Ø/SG/R/CPU/FM

1

CPU BASIC CYLINDER

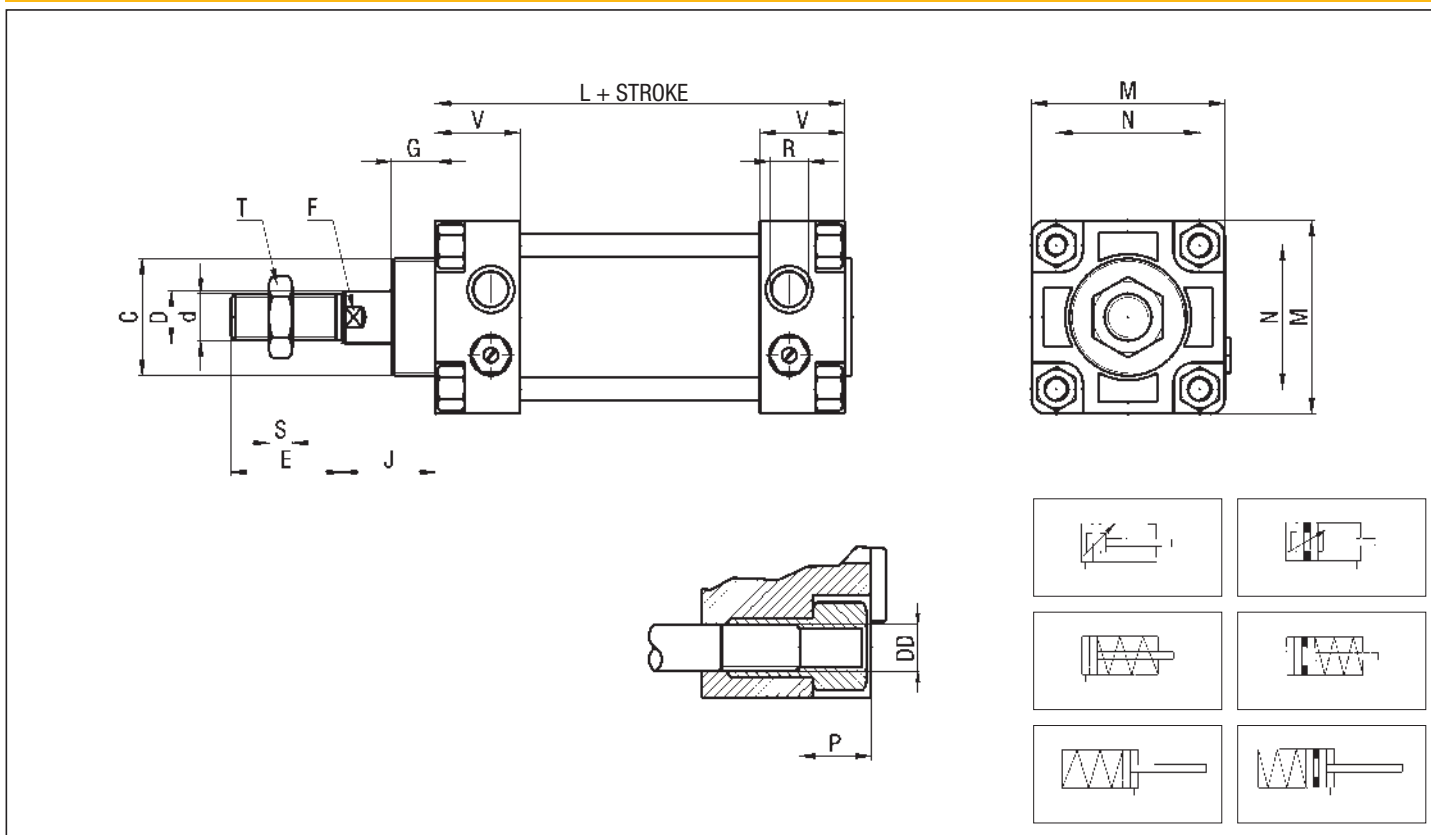

P.S.: Rod nuts supplied as standard

DIMENSIONS AND WEIGHTS BASIC CYLINDER

\varnothing	C	d	D	DD	E	F	G	J	L	M	N	P	R	S	T	V	WEIGHT (g)	INCR. (g) x 10 mm
32	M30x1,5	M10x1,25	12	M6	20	10	15	24	98	45	33	14	G 1/8	6	17	26	517	21
40	M35x1,5	M12x1,25	18	M6	24	13	18	28	110	52	40	14	G 1/4	7	19	29	810	36
50	M40x1,5	M16x1,5	18	M8	32	16	20	35	110	65	49	15	G 1/4	8	24	29	1210	44
63	M40x1,5	M16x1,5	22	M8	32	17	20	35	125	75	59	15	G 3/8	8	24	34	1727	61
80	M45x1,5	M20x1,5	22	M10	40	20	20	42	136	95	75	16	G 3/8	9	30	35	2590	64
100	M55x2	M20x1,5	25	M10	40	22	28	47	145	115	90	16	G 1/2	9	30	39	3970	76

THROUGH ROD

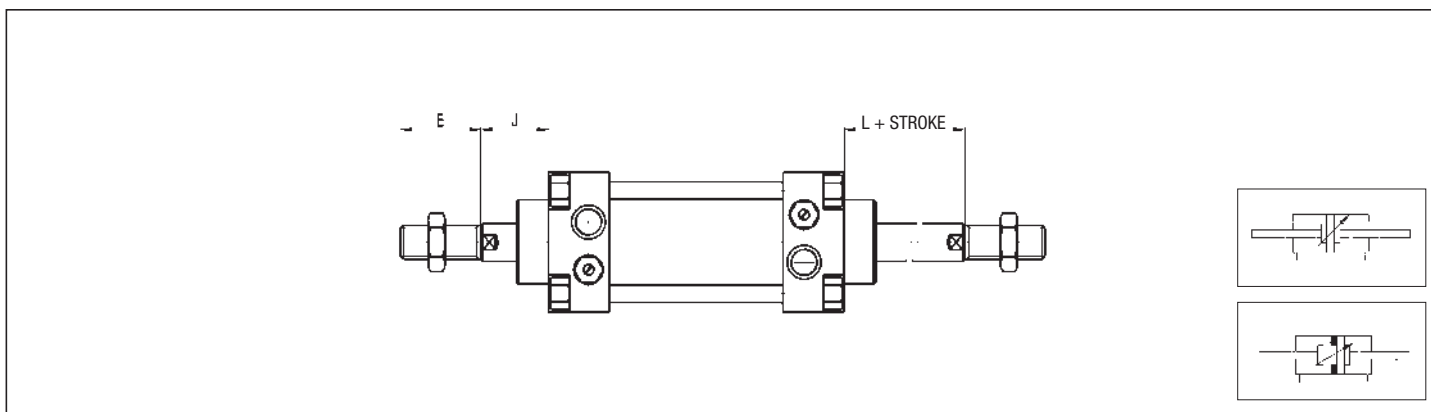

P.S.: Rod nuts supplied as standard

FLANGE - STEEL - CPU/F Ø (Supplied with screws)

Ø	A	B	C	F	G	Q	M
32	32	80	45	7	8	16	130
40	36	90	52	9	8	20	146
50	45	110	65	9	10	25	155
63	50	120	75	9	10	25	170
80	63	150	95	12	12	30	190
100	75	170	115	14	12	35	204

Ø	O	WEIGHT (g)
32	64	145
40	72	195
50	90	390
63	100	530
80	126	1045
100	150	1450

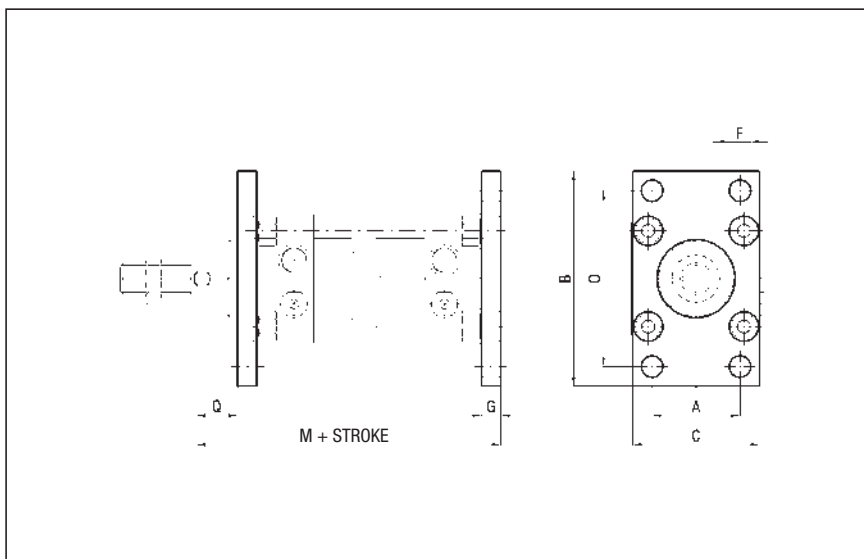

HIGH FOOT - ALUMINIUM - CPU/P Ø (Supplied with screws)

Ø	A	B	C	F	G	H	L
32	32	144	142	7	32	35	22
40	36	164	162	9	36	35	26
50	45	173	166	9	45	43	28
63	50	190	185	9	50	45	30
80	63	215	210	12	63	55	37
100	75	229	219	14	71	55	37

Ø	M	S	WEIGHT (g)
32	45	8	55
40	52	8	65
50	65	10	140
63	75	10	190
80	95	12	370
100	115	12	500

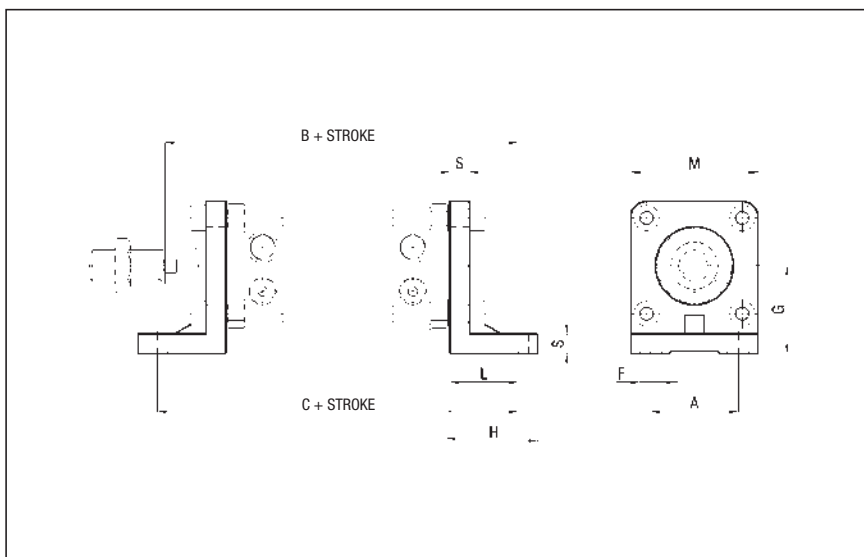

REAR FEMALE HINGE - ALUMINIUM - CPU/CF Ø (Supplied with screws)

Ø	F	I	H	J	k	L	M
32	9	12	142	10	26	45	45
40	12	15	161	12	28	52	52
50	12	17	172	12	32	60	65
63	17	20	190	16	40	70	75
80	17	20	210	16	50	90	95
100	21	25	229	20	60	110	115

Ø	X	WEIGHT (g)
32	20	35
40	23	55
50	27	105
63	30	170
80	32	300
100	37	455

P.S.: This hinge can be used also with square joint of series "X" and "CPU" (see page 1.30)

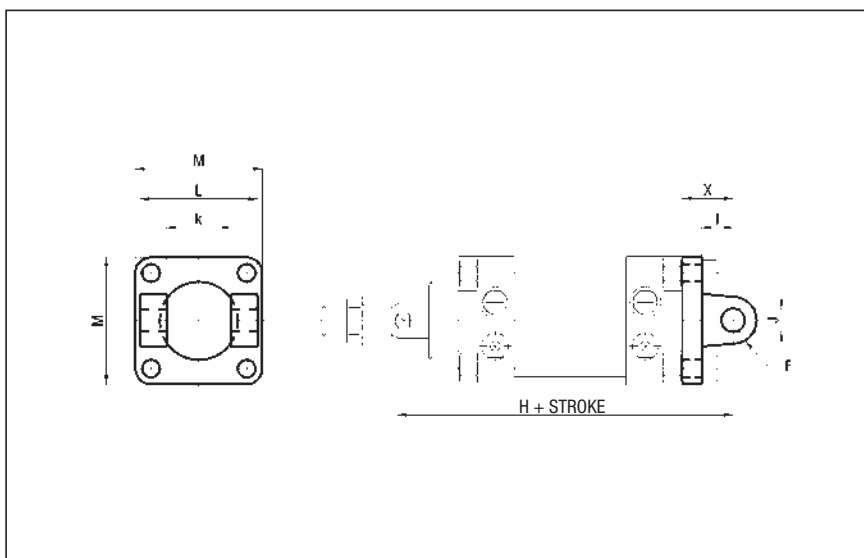

1

PIVOT FOR REAR FEMALE HINGE - STEEL - CPU/CPU/SEC Ø

Ø	BU	EK f7	EL	WEIGHT (g)
32	53	10	46	32
40	60	12	53	52
50	68	12	61	60
63	78	16	71	122
80	98	16	91	152
100	118	20	111	290

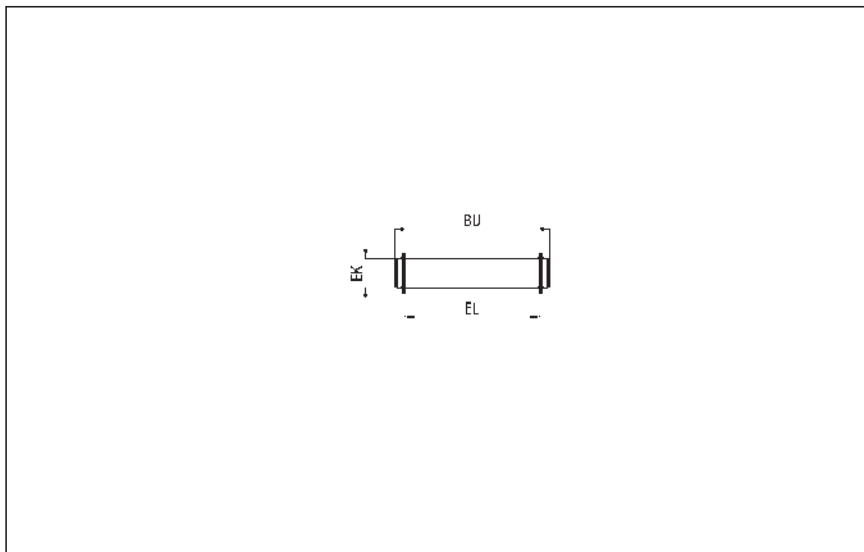

MALE HINGE - ALUMINIUM - CPU/CM Ø

Ø	F	I	H	J H9	M	O	X
32	10	12	142	10	45	26	20
40	12	15	161	12	52	28	23
50	12	17	172	12	65	32	27
63	16	20	190	16	75	40	30
80	16	20	210	16	95	50	32
100	20	25	229	20	115	60	37

Ø	WEIGHT (g)
32	50
40	70
50	140
63	210
80	350
100	565

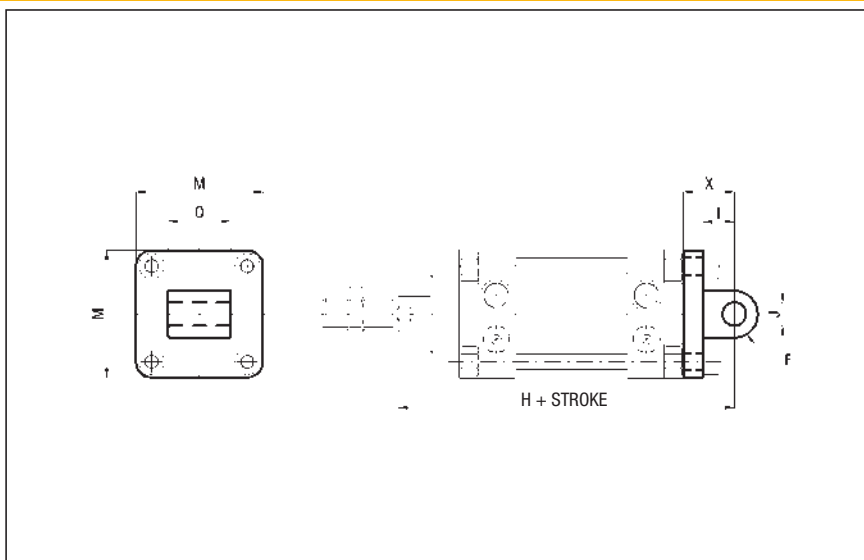

INTERMEDIATE HINGE - STEEL - CX/CPU/CT Ø (Supplied with dowels)

Ø	A	B h14	D e9	E h14	G	M	Q min
32	46	50	12	12	15	6,25	57,5
40	59	63	16	16	20	6,25	67
50	69	73	16	16	20	8,25	74
63	84	90	20	20	25	8,25	81,5
80	102	108	20	20	25	10,25	89,5
100	125	131	25	25	30	10,25	101

Ø	Q max	WEIGHT (g)
32	88,5	130
40	99	306
50	106	370
63	113,5	702
80	130,5	894
100	138	1590

P.S.:
- ADJUSTABLE POSITION (fixing through dowels)
ASSEMBLY:
CX/CPU/CT Ø + cylinder series CPU type M/CX/CPU/CT Ø
- FIXED POSITION
(specify dimension "Q"; fixed on cylinder with completed threaded and galvanized tie rods type "S6", see on page 0.12)

ASSEMBLY:
CX/CPU/CT Ø + cylinder series CPU S6 type MF/CX/CPU/CT Ø

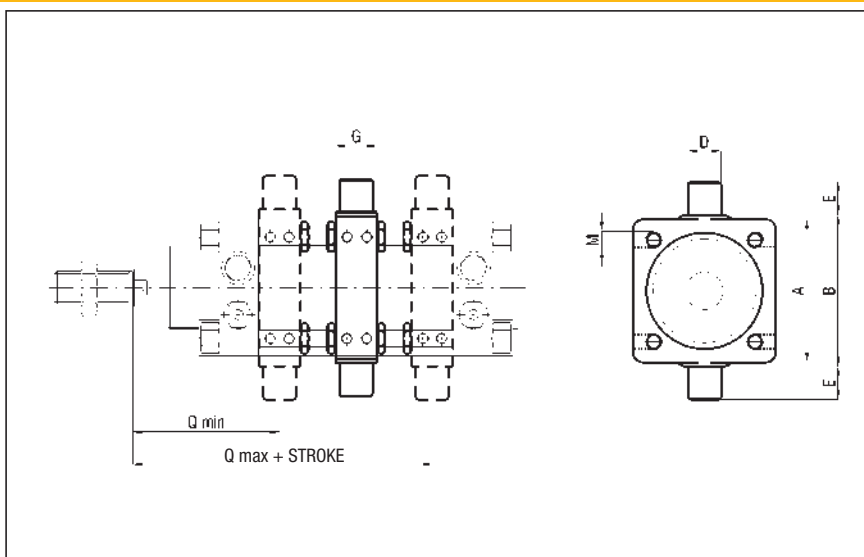

Compact cylinders to AFNOR NF E49-004-1 and NF E49-004-2 standards

series BU

DESCRIPTION

Cylinders series "BU" are available from Ø 20 to Ø 100 and, complying with AFNOR NF E49-004-1 and NF E49-004-2 standards, they're interchangeable also without using anchorages. Besides from Ø 32 to Ø 100 they are available even with end caps distance between centers to ISO 15552 standard. Cylinder series "BU" with magnetic piston type can be supplied with magnetic sensors inserted in the slots arranged on the extruded profile.

TECHNICAL DATA

Operating pressure	Single acting: 2 ÷ 10 bar; Double acting: 1 ÷ 10 bar.
Working temperature	0 ÷ +80 °C (-20 °C with dry air) 0 ÷ +130 °C with seals for high temperatures (-10°C with dry air; for single acting versions: max 100°C)
Fluid	Filtered, unlubricated or continuous lubricated compressed air
Versions	Double acting; Single acting front spring; Single acting rear spring; Through rod; Double push tandem; Double stroke tandem; Opposed tandem; Non-rotating piston rod device; Hollow through rod; Distance between centers to ISO standard
Bore	Ø 20, 25, 32, 40, 50, 63, 80, 100
Port size	Ø 20 - 25 = M 5; Ø 32 ÷ 100 = G 1/8
Standard strokes (mm)	5, 10, 15, 20, 25, 30, 35, 40, 45, 50, 55, 60, 65, 70, 75, 80, 100, 125, 150, 160, 200, 250, 300, 320, 350, 400
Maximum strokes (mm)	Ø 20 - 25 = 200; Ø 32 ÷ 63 = 300; Ø 80 - 100 = 400
Max. strokes single acting (mm)	Ø 20 ÷ 100 = 25
Max. strokes hollow through rod (mm)	Ø 20 ÷ 32 = 40; Ø 40 ÷ 63 = 60; Ø 80 - 100 = 80
Max. strokes non-rotating (mm)	Ø 20 - 25 = 40; Ø 32 ÷ 100 = 80

MATERIALS

End caps	Extruded profile, anodized aluminium alloy
Cylinder barrel	Extruded profile, 20 µm anodized aluminium alloy
Screws	Steel
Piston rod	Ø 20 - 25 = AISI 303 rolled stainless steel Ø 32 ÷ 100 = C45 chromium-plated steel
Rod nut	Steel Stainless steel
Piston rod bearing	Self-lubricating sintered bronze
Piston	Ø 20 - 25 = galvanized steel (supplied with and without magnet) Ø 32 ÷ 100 = aluminium alloy (supplied with and without magnet)
Seals	Polyurethane
Springs	Springs steel

ORDER KEY

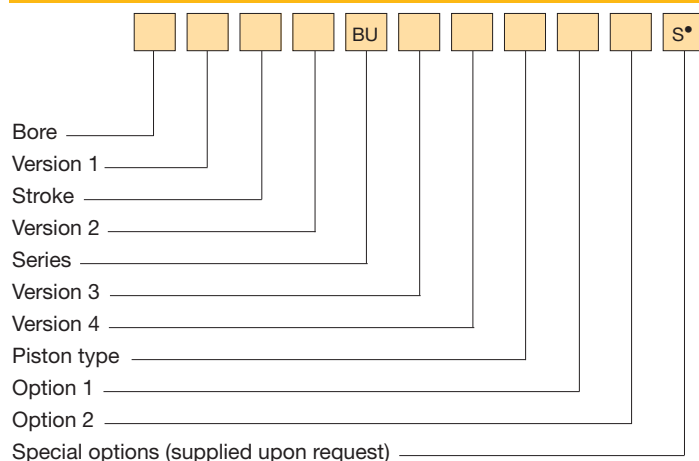

P.S.: *Magnetic sensors* FM 100 (see chapter magnetic sensors from page 1.93)

• See technical data on page 0.12

ORDER EXAMPLES

Basic cylinder Ø50, 50 mm stroke, double acting, magnetic piston type, female threaded piston rod 50/50 DBU/M8

Cylinder Ø63, through rod, 80 mm stroke, double acting, magnetic piston type, stainless steel and male threaded piston rod 63R80 DBU/M17

Cylinder Ø80, double stroke tandem, 50 mm stroke 1 + 100 mm stroke 2, double acting, magnetic piston type, female threaded piston rod 80P50+100 DBU/M8



SPRING THEORETICAL TRACTIVE FORCE

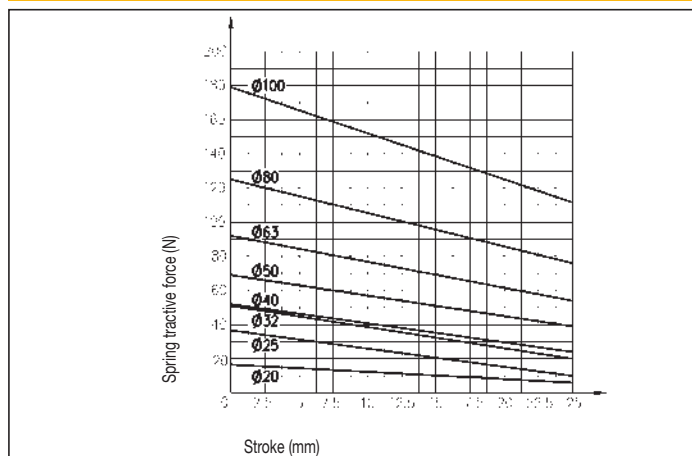

VERSION 1

/ Basic cylinder	T Double push tandem
R Through rod	P Double stroke tandem
F Hollow through rod	V Opposed tandem

VERSION 2

D Double acting	Y Single acting rear spring
S Single acting front spring	

VERSION 3

I End caps distance between centers to ISO 15552 standard*

VERSION 4

A Non-rotating piston rod device (supplied only with female threaded piston rod option)

PISTON TYPE

Non-magnetic /M Magnetic

OPTION 1

1 Stainless steel piston rod and rod nut**	3 Stainless steel piston rod and rod nut and seals for high temperatures***
2 Seals for high temperatures***	

OPTION 2

7 Male threaded piston rod	8 Female threaded piston rod
----------------------------	------------------------------

* Supplied only from Ø 32 to Ø 100
For versions "T", "P" and "V" contact our commercial office
** Supplied as standard for Ø 20 and Ø 25
*** Supplied only with non-magnetic piston type

P.S.: End caps mountings accessories of Version No. 3 (end caps distance between centers to ISO standard) are the same of the cylinders series "X" and "CPU" (see from page 1.28)

SPARE PARTS

SEALS KIT			
Polyurethane	Ø/SG/BU	Through rod, polyurethane	Ø/SG/R/BU
For high temperatures	Ø/SG/BU2	Through rod, for high temperatures	Ø/SG/R/BU2

1

DISPOSITION OF THE SLOTS FOR MAGNETIC SENSORS

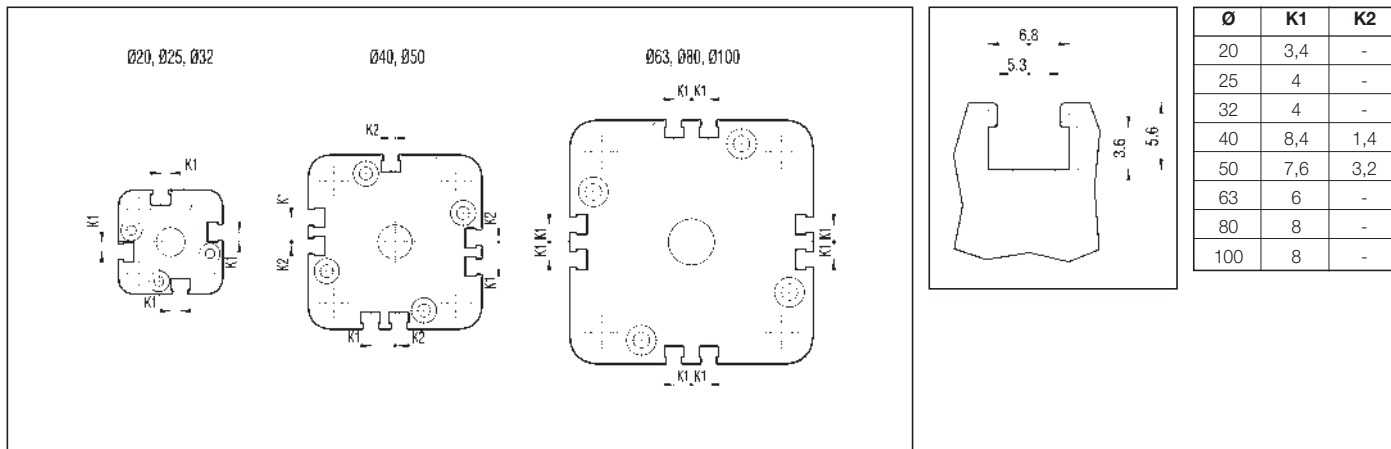

BU BASIC CYLINDER, FEMALE THREADED PISTON ROD

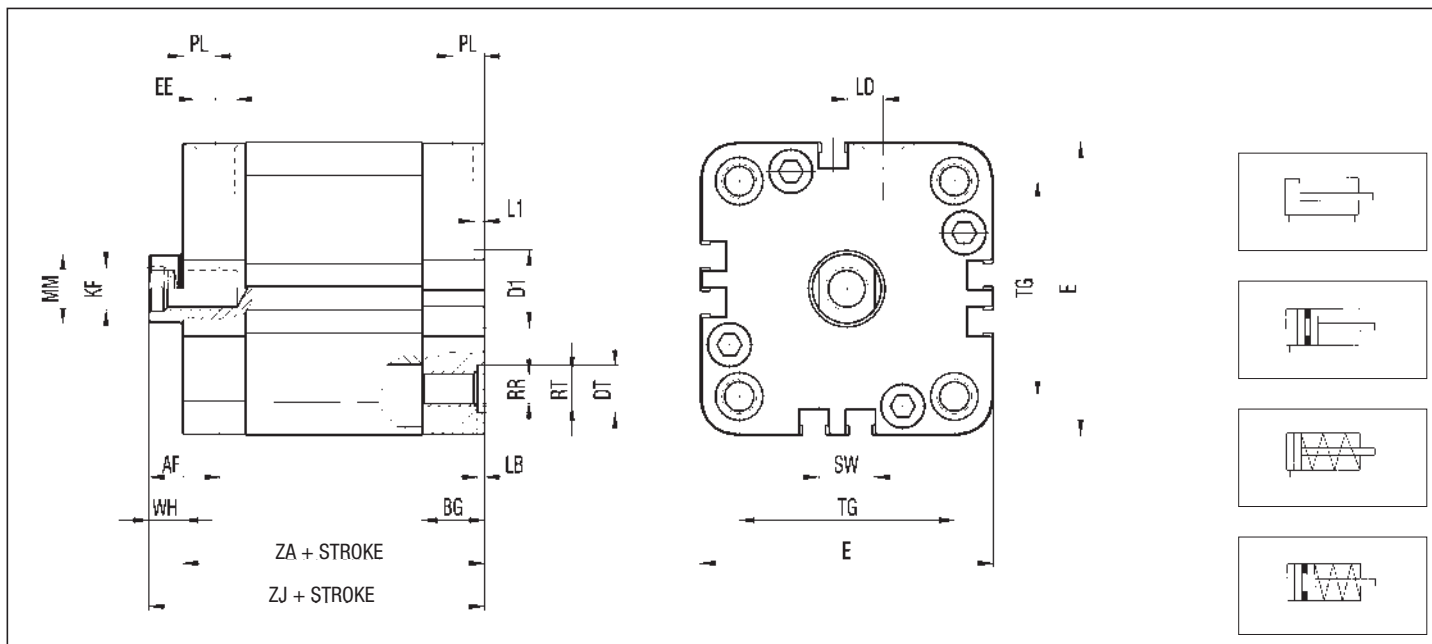

DIMENSIONS AND WEIGHTS BASIC CYLINDER FEMALE THREADED PISTON ROD

Ø	AF	BG*	D	D1 H11	DT H13	E	EE	KF	LB	LD	L1	MM	PL	RR	RT	SW	TG**		WH	ZA	ZB	ZJ	WEIGHT (g)	INCR. (g) x 5 mm
																	A	I						
20	11,5	12	3,8	12	8	36	M5	M6	4,4	4,5	2,5	10	7	4,3	M5	8	22	-	6	37	62	43	130	10
25	11,5	13	3,8	12	8	40	M5	M6	4,4	5,5	2,5	10	8	4,3	M5	8	26	-	6	39	65	45	160	11
32	13	14,5	4,5	14	10,5	50	G 1/8	M8	5,4	5	2,5	12	7,5	5,3	M6	10	32	32,5	7	44	73,5	51	215	16
40	13	14,5	4,5	14	10,5	60	G 1/8	M8	5,4	9,5	2,5	12	7,5	5,3	M6	10	42	38	7	45	75,5	52	330	20
50	16,5	14,5	6	18	11	68	G 1/8	M10	1,7	8,5	2,5	16	7,5	6,4	M8	13	50	46,5	8	45	75,5	53	470	25
63	16,5	14,5	6	18	11	84	G 1/8	M10	1,7	-17,5	2,5	16	7,5	6,4	M8	13	62	56,5	8	50	85,5	58	710	37
80	21	16,5	8	23	15	102	G 1/8	M12	1	-21	3	20	8,5	8,4	M10	16	82	72	8	56	95,5	64	1295	50
100	24,5	19,5	10	28	15	123	G 1/8	M16	3,5	-25	3	25	10	8,4	M10	21	103	89	10	67	114,5	77	2250	70

* IN THE TANDEM VERSIONS (T, P, V), DIMENSION (BG - LB) IS REDUCED OF 5 mm

** A - AFNOR
I - ISO

**SINGLE ACTING, REAR SPRING,
FEMALE THREADED PISTON ROD**

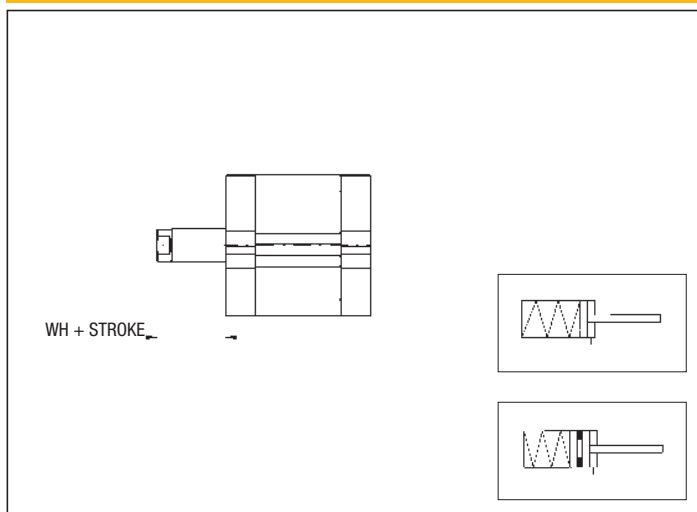

**FEMALE THREADED THROUGH ROD AND
SINGLE ACTING, FEMALE THREADED THROUGH ROD**

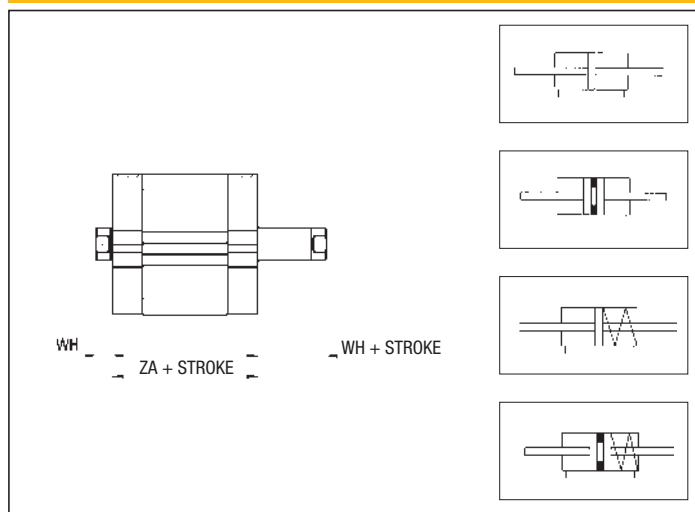

**HOLLOW FEMALE THREADED THROUGH ROD AND
SINGLE ACTING, HOLLOW FEMALE THREADED THROUGH ROD**

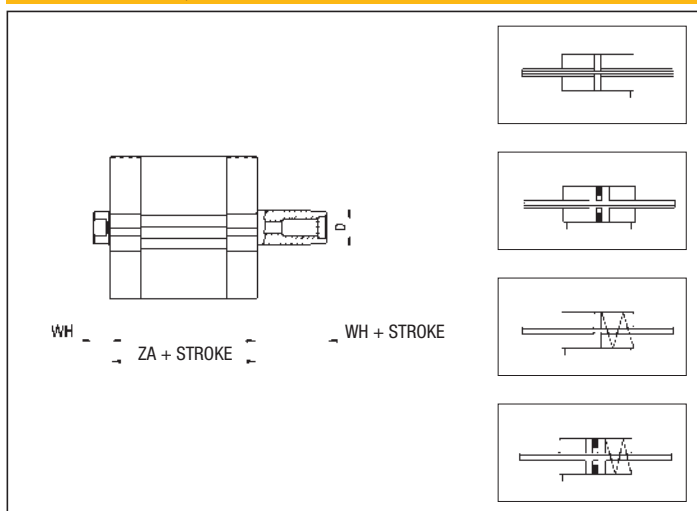

**DOUBLE PUSH TANDEM,
FEMALE THREADED PISTON ROD**

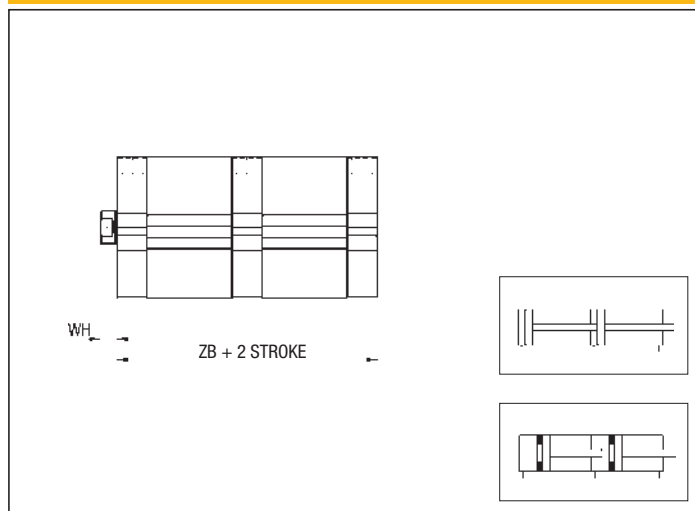

DOUBLE STROKE TANDEM, FEMALE THREADED PISTON ROD

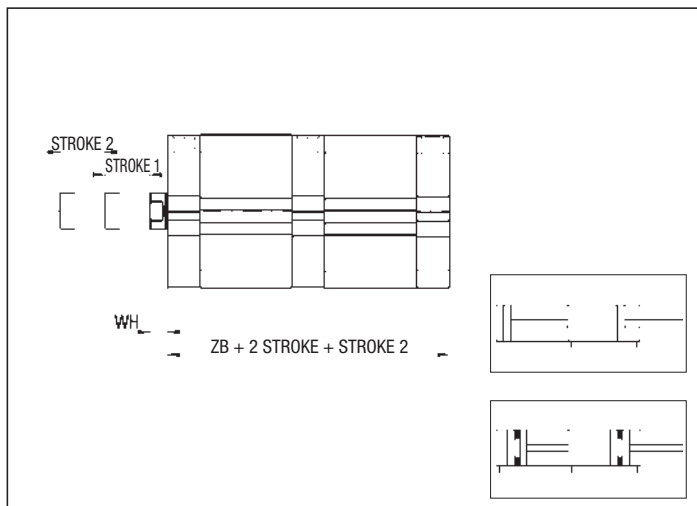

OPPOSED TANDEM, FEMALE THREADED PISTON ROD

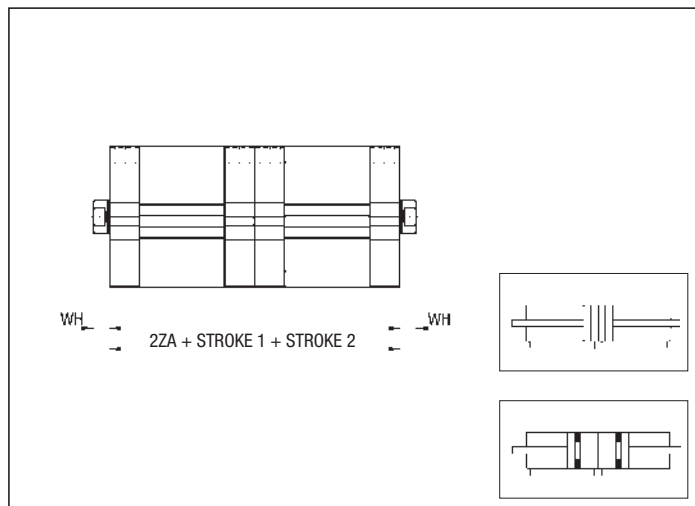

1

BU BASIC CYLINDER, MALE THREADED PISTON ROD

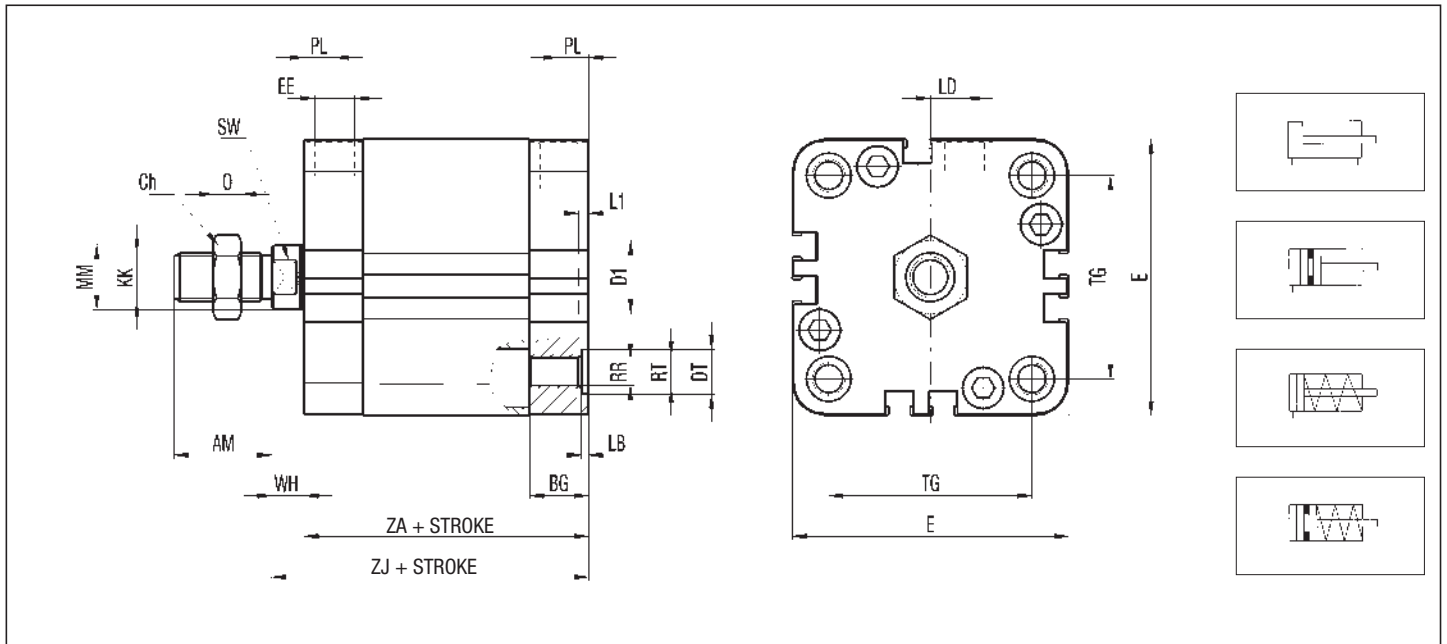

P.S.: Rod nut supplied as standard

DIMENSIONS AND WEIGHTS BASIC CYLINDER MALE THREADED PISTON ROD

Ø	AM	BG*	Ch	D	D1 H11	DT H13	E	EE	KK	LB	LD	L1	MM	O	PL	RR	RT	SW	TG**		WH	ZA	ZB	ZJ	WEIGHT (g)	INCR. (g) x 5 mm
																			A	I						
20	22	12	17	3,8	12	8	36	M5	M10x1,25	4,4	4,5	2,5	10	6	7	4,3	M5	8	22	-	6	37	62	43	150	10
25	22	13	17	3,8	12	8	40	M5	M10x1,25	4,4	5,5	2,5	10	6	8	4,3	M5	8	26	-	6	39	65	45	180	11
32	22	14,5	17	4,5	14	10,5	50	G 1/8	M10x1,25	5,4	5	2,5	12	6	7,5	5,3	M6	10	32	32,5	7	44	73,5	51	240	16
40	22	14,5	17	4,5	14	10,5	60	G 1/8	M10x1,25	5,4	9,5	2,5	12	6	7,5	5,3	M6	10	42	38	7	45	75,5	52	355	20
50	24	14,5	19	6	18	11	68	G 1/8	M12x1,25	1,7	8,5	2,5	16	7	7,5	6,4	M8	13	50	46,5	8	45	75,5	53	505	25
63	24	14,5	19	6	18	11	84	G 1/8	M12x1,25	1,7	-17,5	2,5	16	7	7,5	6,4	M8	13	62	56,5	8	50	85,5	58	745	37
80	32	16,5	24	8	23	15	102	G 1/8	M16x1,5	1	-21	3	20	8	8,5	8,4	M10	16	82	72	8	56	95,5	64	1360	50
100	40	19,5	30	10	28	15	123	G 1/8	M20x1,5	3,5	-25	3	25	9	10	8,4	M10	21	103	89	10	67	114,5	77	2390	70

* IN THE TANDEM VERSIONS (T, P, V), DIMENSION (BG - LB) IS REDUCED OF 5 mm

** A - AFNOR
I - ISO

SINGLE ACTING, REAR SPRING, MALE THREADED PISTON ROD

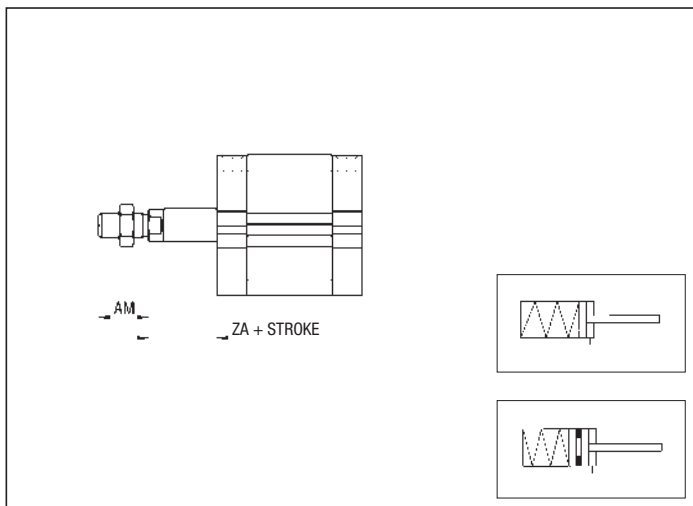

P.S.: Rod nut supplied as standard

MALE THREADED THROUGH ROD AND SINGLE ACTING, MALE THREADED THROUGH ROD

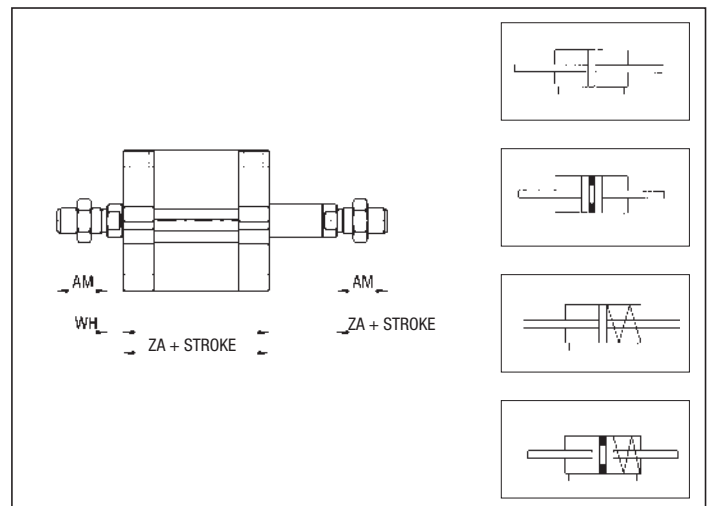

P.S.: Rod nuts supplied as standard

HOLLOW MALE THREADED THROUGH ROD AND SINGLE ACTING, HOLLOW MALE THREADED THROUGH ROD

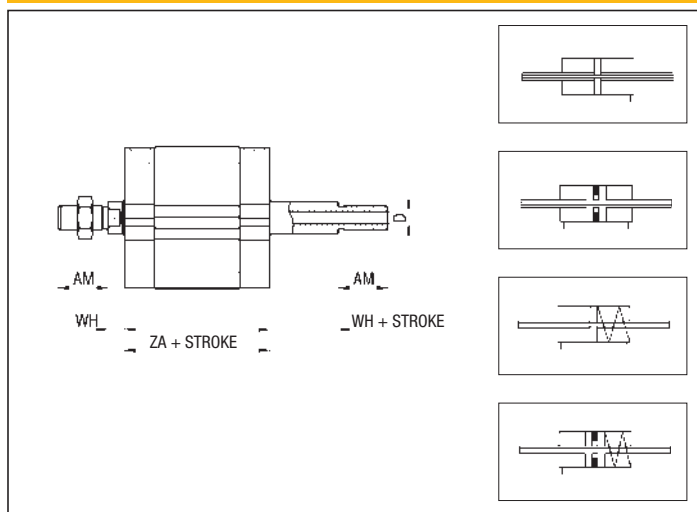

P.S.: Rod nuts supplied as standard

DOUBLE PUSH TANDEM, MALE THREADED PISTON ROD

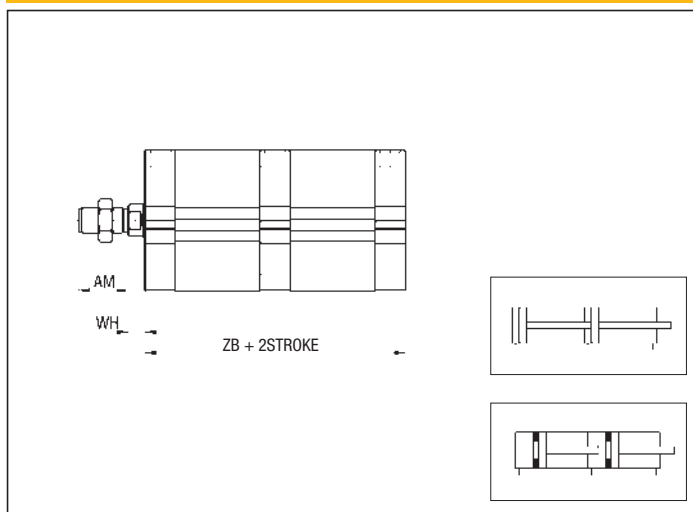

P.S.: Rod nut supplied as standard

DOUBLE STROKE TANDEM, MALE THREADED PISTON ROD

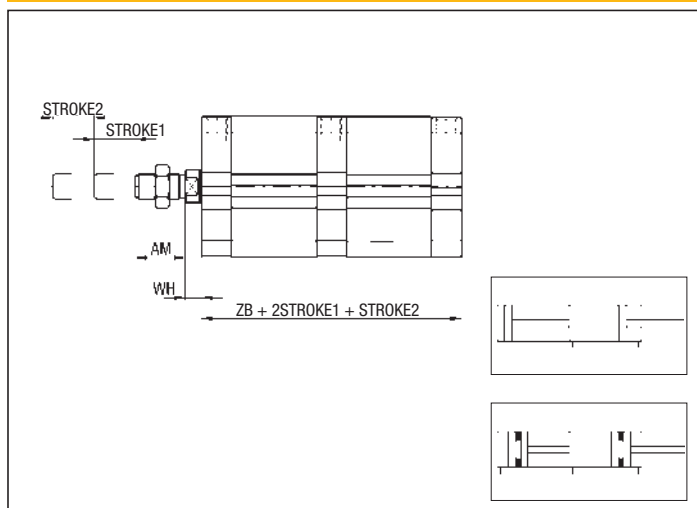

P.S.: Rod nut supplied as standard

OPPOSED TANDEM, MALE THREADED PISTON ROD

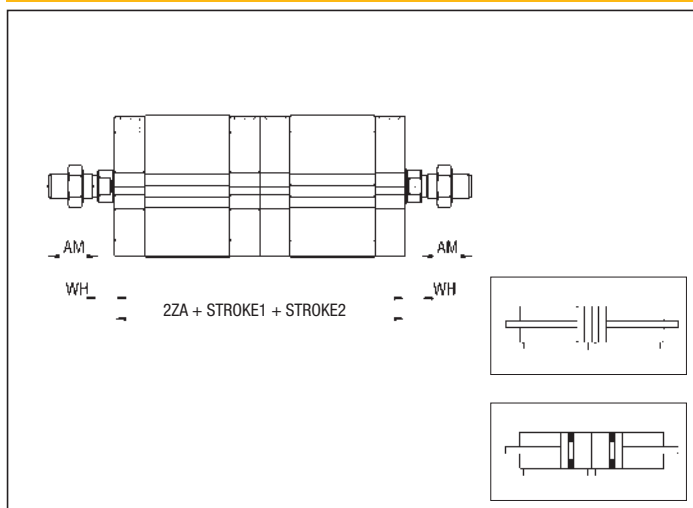

P.S.: Rod nuts supplied as standard

BU NON-ROTATING BASIC CYLINDER

1

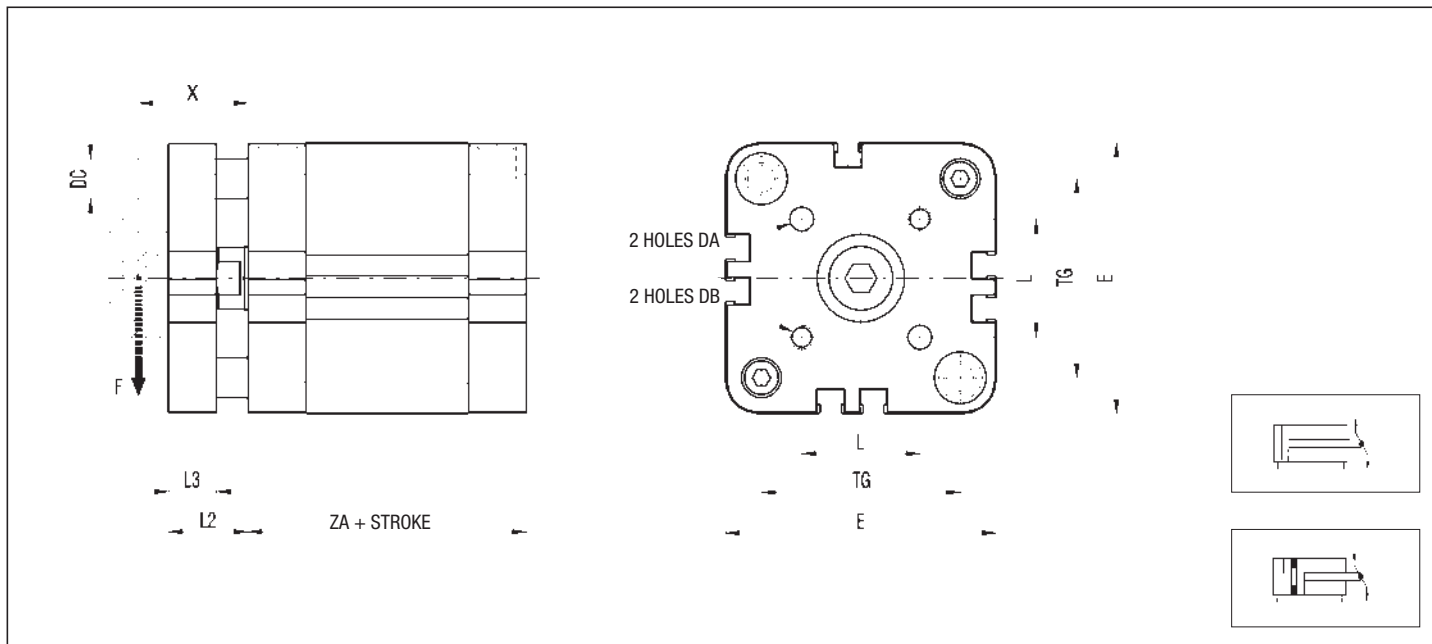

DIMENSIONS AND WEIGHTS

Ø	DA	DB	DC	E	L	L2	L3	TG**		ZA	WEIGHT (g)	INCR. (g) x 5 mm
								A	I			
20	4	M4	6	36	12	14	8	22	-	37	170	15
25	5	M5	6	40	15,6	14	8	26	-	39	210	16
32	5	M5	8	50	19,8	17	10	32	32,5	44	300	25
40	5	M5	8	60	23,3	17	10	42	38	45	440	30
50	6	M6	10	68	29,7	20	12	50	46,5	45	610	40
63	6	M6	10	84	35,4	20	12	62	56,5	50	930	55
80	8	M8	12	102	46	22	14	82	72	56	1690	75
100	10	M10	12	123	56,6	24	14	103	89	67	2950	105

** A - AFNOR
I - ISO

MAX. PERMISSIBLE LOAD - NON-ROTATING BU

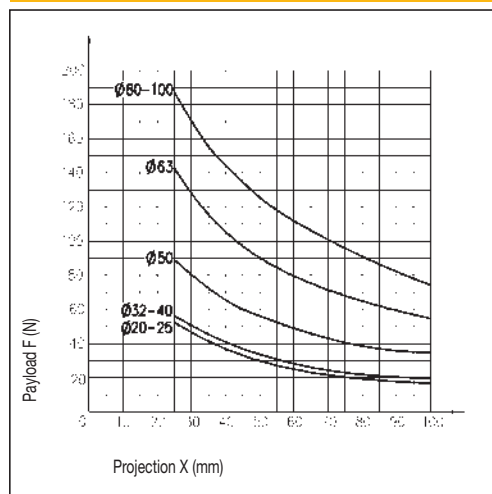

FLANGE Ø 20 - 25 - ALUMINIUM - BU/F Ø
(Supplied with screws) - STEEL - BU/F Ø AC

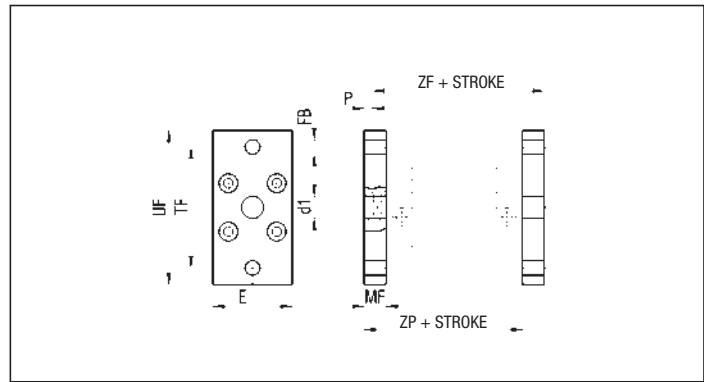

FLANGE Ø 32 ÷ 100 - ALUMINIUM - BU/F Ø
(Supplied with screws) - STEEL - BU/F Ø AC

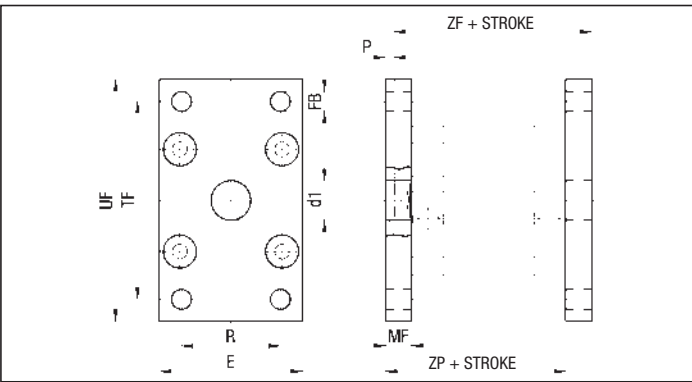

Ø	d1 H11	E	FB H13	MF	P	R	TF	UF	ZF	ZP	WEIGHT ALL (g)	WEIGHT STEEL (g)
20	12	36	6,6	10	4	-	55	70	53	47	70	160
25	12	40	6,6	10	4	-	60	76	55	49	80	200
32	14	50	7	10	3	32	65	80	61	54	100	260
40	14	60	9	10	3	36	82	102	62	55	160	420
50	18	68	9	12	4	45	90	110	65	57	240	600
63	18	87	9	15	7	50	110	130	73	65	450	1200
80	23	107	12	15	7	63	135	160	79	71	690	1800
100	28	128	14	15	5	75	163	190	92	82	980	2550

IN THE TANDEM VERSIONS (T, P, V),
ADD THE READING "TANDEM" TO THE CODE.
EXAMPLE: BU/F Ø TANDEM

LOW FOOT - STEEL - BU/PB Ø

Ø	AB H13	AH	AU	AT	E	F	SA	TR	WEIGHT (g)
20	6,6	27	16	4	36	22	69	22	32
25	6,6	30	16	4	40	22	71	26	38
32	6,6	32	18	5	50	26	80	32	66
40	9	42,5	20	5	60	28	85	42	100
50	9	47	24	6	68	32	93	50	150
63	11	59,5	27	6	84	39	104	62	250
80	11	65,5	30	8	102	42	116	82	380
100	13,5	78,5	33	8	123	45	133	103	500

IN THE TANDEM VERSIONS (T, P, V), ADD THE READING
"TANDEM" TO THE CODE.
EXAMPLE: BU/PB Ø TANDEM

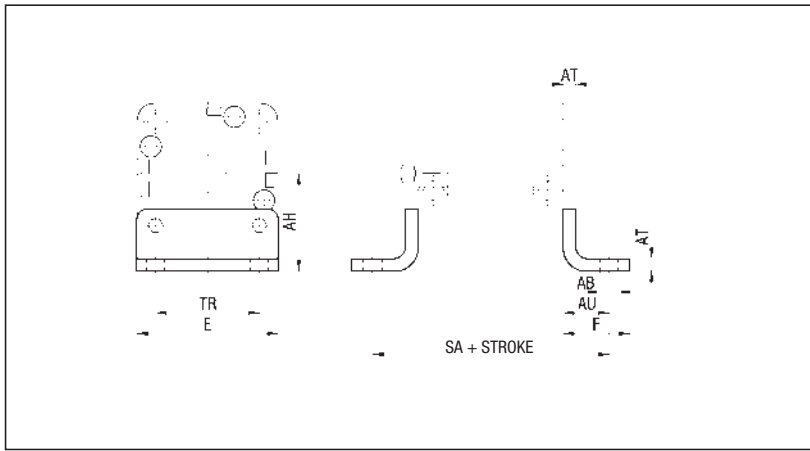

REAR MALE HINGE - ALUMINIUM - BU/CM Ø
(Supplied with screws) - STEEL - BU/CM Ø AC

Ø	CD H9	E	EW h14	FL	L	L2	XD	WEIGHT ALL (g)	WEIGHT STEEL (g)
20	8	34	16	20	14	2,6	63	21	80
25	8	38	16	20	14	2,6	65	27	85

P.S.: THIS MOUNTING CAN BE USED WITH THE REAR HINGE
MOUNTING OF CYLINDERS SERIES "U" (SEE ON PAGE 1.6)

IN THE TANDEM VERSIONS (T, P),
ADD THE READING "TANDEM" TO THE CODE.
EXAMPLE: BU/CM Ø AC TANDEM

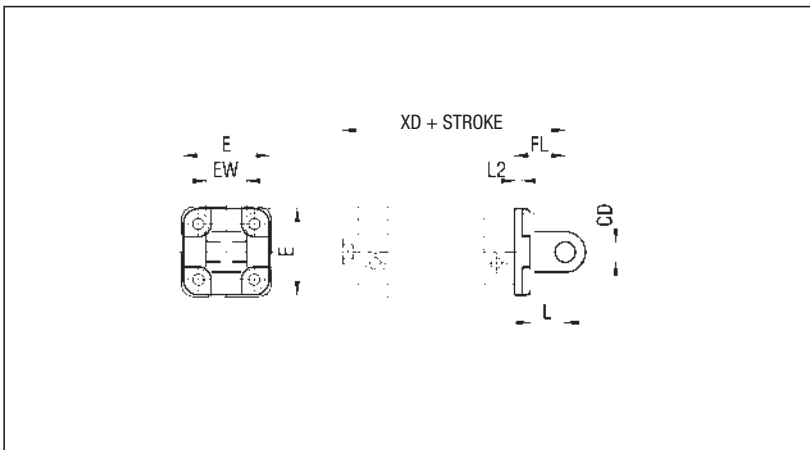

1

REAR FEMALE HINGE - ALUMINIUM - BU/CF Ø
 (Supplied with screws) - STEEL - BU/CF Ø AC

Ø	CB H14	CD H9	E	FL	L	L2	UB h14	XD	WEIGHT ALL (g)	WEIGHT ACC.(g)
32	26	10	48	22	13	5,5	45	73	60	170
40	28	12	58	25	16	5,5	52	77	104	270
50	32	12	66	27	16	6,5	60	80	142	378
63	40	16	83	32	21	6,5	70	90	240	645
80	50	16	102	36	23	10	90	100	420	1070
100	60	20	123	41	26	10	110	118	721	1730

P.S.: THIS HINGE CAN BE USED ALSO WITH PIVOT AND MALE HINGE OR SQUARE JOINT OF SERIES "X" AND "CPUI" (SEE FROM PAGE 1.29)

IN THE TANDEM VERSIONS (T, P, V),
 ADD THE READING "TANDEM" TO THE CODE.

EXAMPLE: BU/CF Ø TANDEM

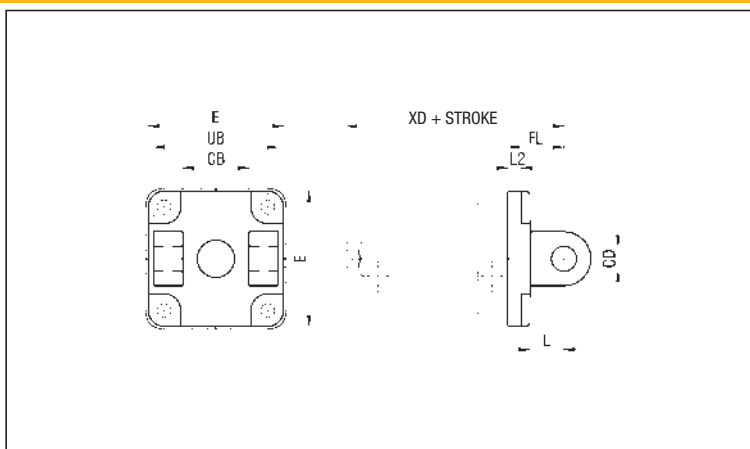

FLOATING HINGE - STEEL - BU/CTA Ø (Supplied with screws)

Ø	L1	P	TD e9	TL h14	TM h14	UW	XV	WEIGHT (g)
20	14	8	12	12	38	35	57	100
25	14	8	12	12	42	39	59	114
32	14	7	12	12	52	46	65	132
40	19	12	16	16	63	59	71	278
50	19	11	16	16	75	69	72	362
63	24	16	20	20	90	84	82	624
80	24	16	20	20	110	102	88	765
100	29	19	25	25	132	125	106	1464

IN THE TANDEM VERSIONS (T, P, V),
 ADD THE READING "TANDEM" TO THE CODE.

EXAMPLE: BU/CTA Ø TANDEM

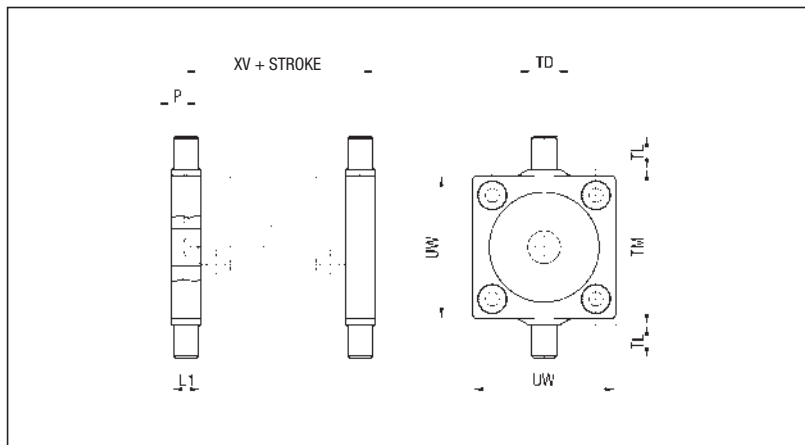

ACCESSORIES FOR CYLINDERS WITH END CAPS DISTANCE BETWEEN CENTERS TO ISO 15552 STANDARD

The accessories of Version No. 3 (end caps distance between centers to ISO standard) are the same of the cylinders series "X" and "CPUI" to ISO 15552 standard (see from page 1.28)

DESCRIPTION

Cylinders series "B" are widely used in locking applications thanks to compact design and to easy mounting through holes on cylinder body. In the version with magnetic piston type, cylinders series "B" are supplied with magnetic sensors.

TECHNICAL DATA

Operating pressure	1 ± 10 bar
Working temperature	0 ÷ +80 °C (-20 °C with dry air) 0 ÷ +150 °C with seals for high temperatures (-10 °C with dry air)
Fluid	Filtered, unlubricated or continuous lubricated compressed air
Versions	Double acting; Single acting front spring; Single acting rear spring; Through rod; Non-rotating piston rod device.
Bore	Ø 12, 16, 20, 25, 32, 40, 50, 63, 80, 100
Port size	Ø 12 ÷ 20 = M5 Ø 25 ÷ 63 = G 1/8 Ø 80 - 100 = G 1/4
Standard strokes	See tables

MATERIALS

Front end cap	Ø 12 ÷ 25: Brass Ø 32 ÷ 100: Aluminium
Rear end cap	Anodized aluminium alloy
Cylinder barrel	Extruded profile, 15 µm anodized aluminium alloy
Piston rod	AISI 303 stainless steel
Piston rod bearing	Bronze + PTFE
Piston	Ø 12 ÷ 32: Delrin (supplied with and without magnet) Ø 40 ÷ 100: Aluminium (supplied with and without magnet)
Seals	Ø 12 ÷ 32: NBR rubber Ø 40 ÷ 100: Polyurethane Ø 12 ÷ 100: Viton®
Cushioning washer	Vulkollan
Spring	AISI 303 stainless steel

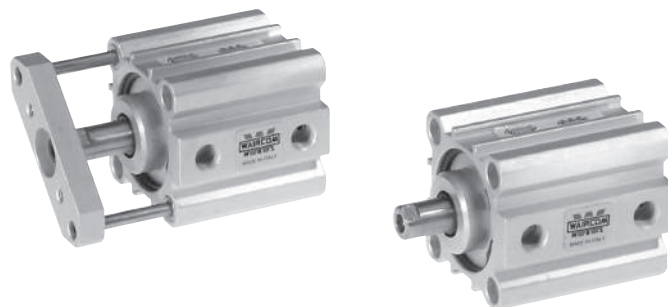

SPRING THEORETICAL TRACTIVE FORCE

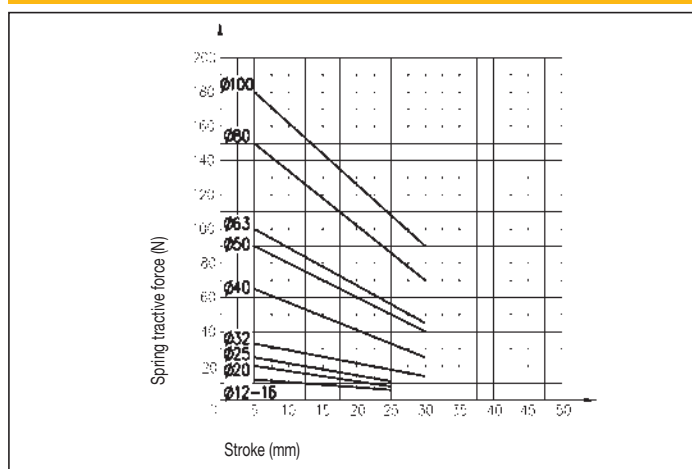

ORDER KEY

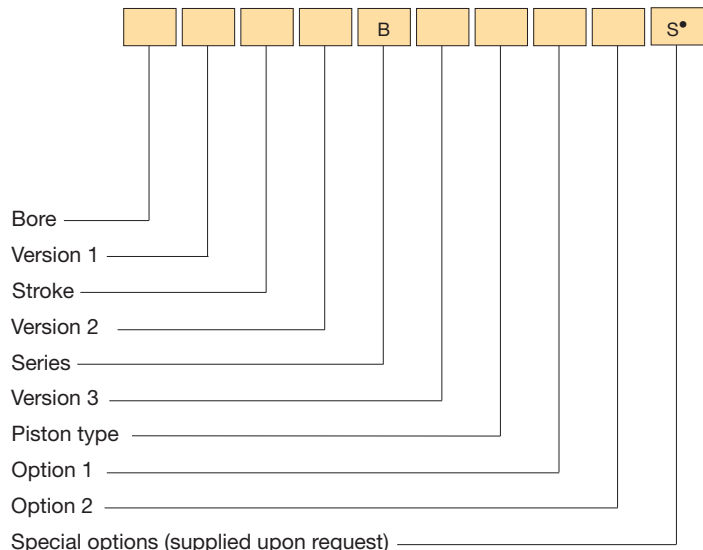

VERSION 1

/ Basic cylinder R Through rod

VERSION 2

D Double acting Y Single acting rear spring
S Single acting front spring

VERSION 3

A Non-rotating piston rod device*

PISTON TYPE

Non-magnetic /M Magnetic

OPTION 1

1 Male hinge mounting

OPTION 2

2 Seals for high temperatures

* Supplied only from Ø 20 to Ø 100

PS.: *Magnetic sensors* FM 100 (see chapter magnetic sensors from page 1.93)
• See technical data on page 0.12

ORDER EXAMPLES

- Basic cylinder Ø16, 50 mm stroke, double acting, non-magnetic piston type 16/50 DB
- Basic cylinder Ø20, 60 mm stroke, double acting, non-magnetic piston type, seals for high temperatures 20/60 DB2
- Cylinder Ø32, through rod, 80 mm stroke, double acting, magnetic piston type 32R80 DB/M

SPARE PARTS

Contact the commercial office

1

SINGLE AND DOUBLE ACTING

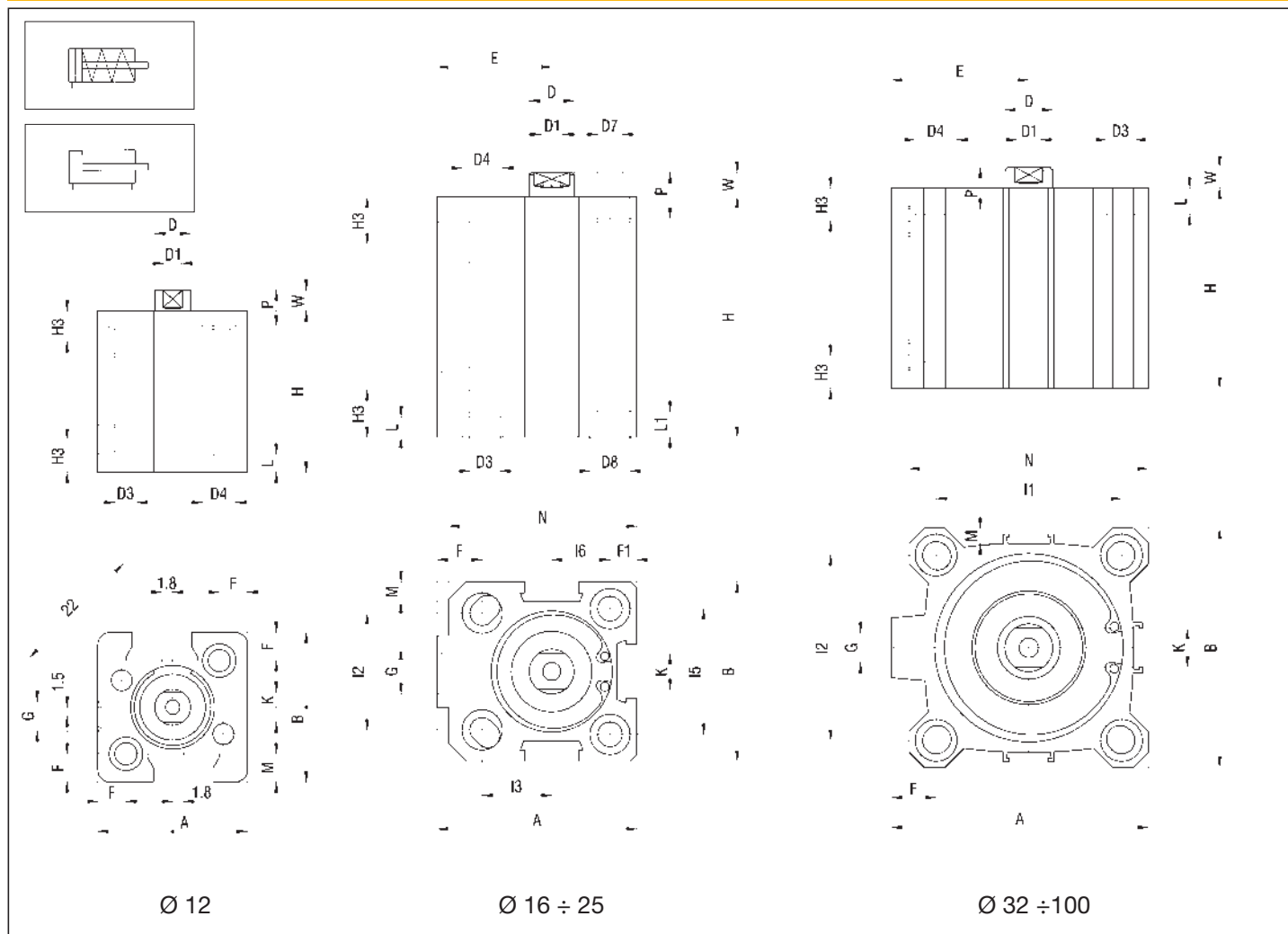

DIMENSIONS AND WEIGHTS

Ø	A	B	D	D1	D3	D4	D7	D8	E	F	F1	G	H3	I1	I2	I3	I5	I6	K	L	L1	M	N	P	W	WEIGHT (g)	INCR. (g) x10 mm
12	25	25	6	M3	3,7	5,6	-	-	-	4,7	-	M5	5,5	-	-	-	-	-	5	3,5	-	4,7	-	6	3,5	33,5	11,5
16	34	30	8	M4	4,7	7,5	3,7	5,6	19	7	5	M5	8	-	18	12	20	10	6	4,6	3,5	4	32	8	4,5	74	16,5
20	40	36	10	M5	5,8	9	5,8	9	22	7	5,2	M5	8	-	20	15	25,5	12,7	8	5,7	5,7	5,7	38,5	10	5	106	24,5
25	44,5	40	10	M5	5,8	9	5,8	9	24,5	9	6	G1/8	10,5	-	26	15,5	28	14	8	5,7	5,7	4,5	42	10	5,5	145	32
32	51	46	12	M6	5,8	9	-	-	27	9	-	G1/8	11,5	36	32	-	-	10	5,7	-	4	48	12	6	172	36	
40	58	55	12	M6	5,8	9	-	-	30,5	9,5	-	G1/8	11	42	42	-	-	10	5,7	-	4	55	12	6	225	40	
50	70	65	16	M8	6,8	11	-	-	37,5	12,5	-	G1/8	11,5	50	50	-	-	13	6,8	-	4	65	12	7,5	359	63	
63	86	80	16	M8	9	14	-	-	46	15	-	G1/8	11	62	62	-	-	13	8,8	-	5	80	14	7	552	70	
80	105	100	20	M10	9	14	-	-	55	14	-	G1/4	14	82	82	-	-	17	9	-	6	100	15	8	1072	105	
100	131	124	25	M12	11	17,2	-	-	69	17,5	-	G1/4	16	103	103	-	-	22	11	-	7,5	124	20	10	1920	160	

"H" DIMENSION-SINGLE ACTING

Ø	STROKE (mm)					
	5	10	15	20	25	30
12	22	27	-	-	-	-
16	32	37	42	47	52	-
20	32	37	42	47	52	-
25	33,5	38,5	43,5	48,5	53,5	-
32	34,5	39,5	44,5	49,5	54,5	59,5
40	34,5	39,5	44,5	49,5	54,5	59,5
50	-	44,5	49,5	54,5	59,5	64,5
63	-	47	52	57	62	67
80	-	56	61	66	71	76
100	-	66	71	76	81	86

"H" DIMENSION-DOUBLE ACTING

Ø	STROKE (mm)										
	5	10	15	20	25	30	40	50	60	80	100
12	22	27	32	37	42	47	57	-	-	-	-
16	32	37	42	47	52	58	68	78	-	-	-
20	32	37	42	47	52	58	68	78	-	-	-
25	33,5	38,5	43,5	48,5	53,5	58,5	69,5	79,5	-	-	-
32	34,5	39,5	44,5	49,5	54,5	59,5	69,5	79,5	89,5	109,5	129,5
40	34,5	39,5	44,5	49,5	54,5	59,5	69,5	79,5	89,5	109,5	129,5
50	-	44,5	49,5	54,5	59,5	64,5	74,5	84,5	94,5	114,5	134,5
63	-	47	52	57	62	67	77	87	97	117	137
80	-	56	61	66	71	76	86	96	106	126	146
100	-	66	71	76	81	86	96	106	116	136	156

SINGLE ACTING MAGNETIC

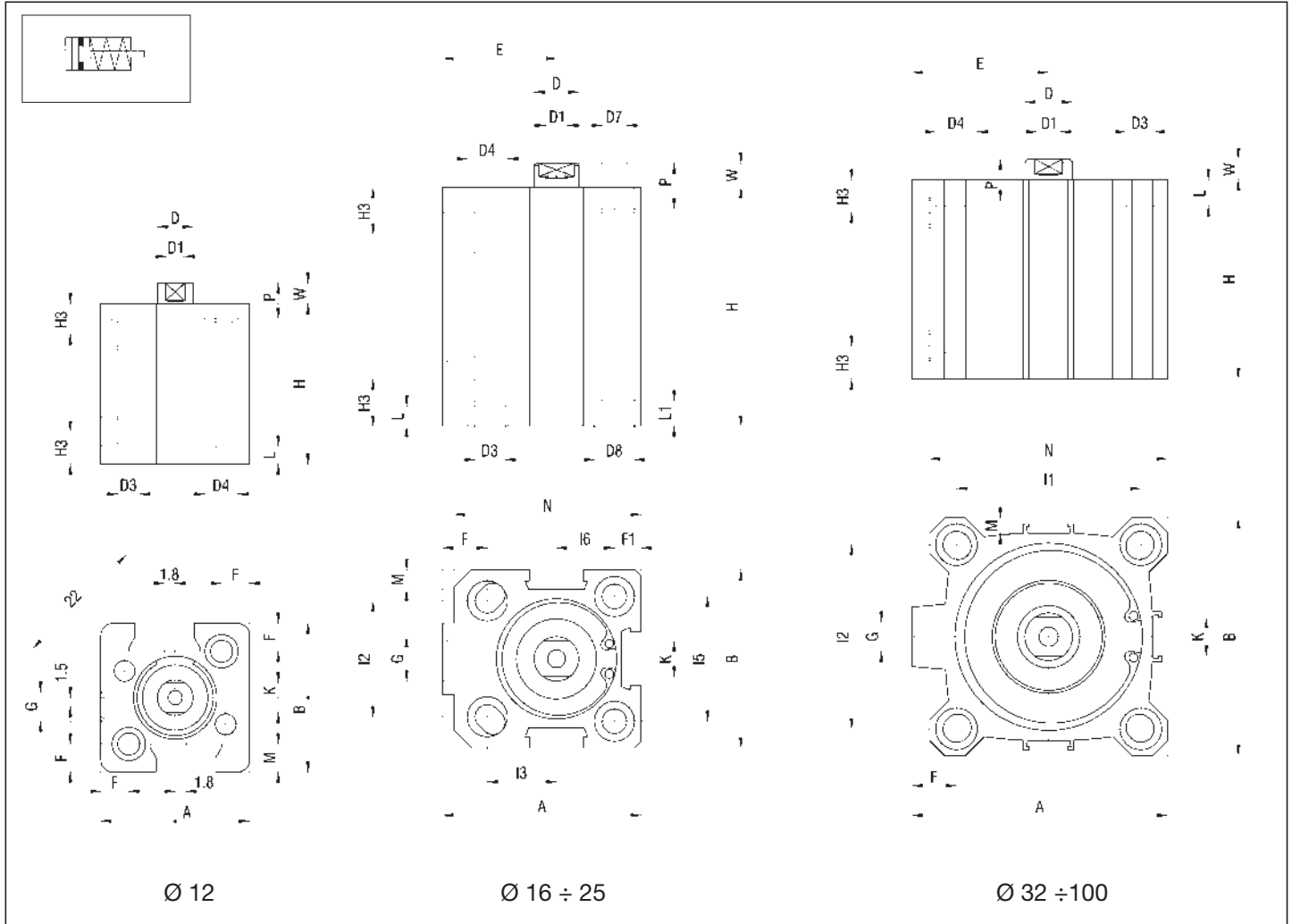

DIMENSIONS AND WEIGHTS

Ø	A	B	D	D1	D3	D4	D7	D8	E	F	F1	G	H3	I1	I2	I3	I5	I6	K	L	L1	M	N	P	W	WEIGHT (g)	INCR. (g) x10 mm
12	25	25	6	M3	3,7	5,6	-	-	-	4,7	-	M5	5,5	-	-	-	-	5	3,5	-	4,7	-	6	3,5	33,5	11,5	
16	34	30	8	M4	4,7	7,5	3,7	5,6	19	7	5	M5	8	-	18	12	20	10	6	4,6	3,5	4	32	8	4,5	74	16,5
20	40	36	10	M5	5,8	9	5,8	9	22	7	5,2	M5	8	-	20	15	25,5	12,7	8	5,7	5,7	5,7	38,5	10	5	106	24,5
25	44,5	40	10	M5	5,8	9	5,8	9	24,5	9	6	G1/8	10,5	-	26	15,5	28	14	8	5,7	5,7	4,5	42	10	5,5	145	32
32	51	46	12	M6	5,8	9	-	-	27	9	-	G1/8	11,5	36	32	-	-	10	5,7	-	4	48	12	6	172	36	
40	58	55	12	M6	5,8	9	-	-	30,5	9,5	-	G1/8	11	42	42	-	-	10	5,7	-	4	55	12	6	225	40	
50	70	65	16	M8	6,8	11	-	-	37,5	12,5	-	G1/8	11,5	50	50	-	-	13	6,8	-	4	65	12	7,5	359	63	
63	86	80	16	M8	9	14	-	-	46	15	-	G1/8	11	62	62	-	-	13	8,8	-	5	80	14	7	552	70	
80	105	100	20	M10	9	14	-	-	55	14	-	G1/4	14	82	82	-	-	17	9	-	6	100	15	8	1072	105	
100	131	124	25	M12	11	17,2	-	-	69	17,5	-	G1/4	16	103	103	-	-	22	11	-	7,5	124	20	10	1920	160	

"H" DIMENSION

Ø	STROKE (mm)						
	4	5	10	15	20	25	30
12	-	32	37	-	-	-	-
16	36	37	42	47	52	63	-
20	36	37	42	47	52	63	-
25	-	43,5	48,5	53,5	58,5	64,5	-
32	-	44,5	49,5	54,5	59,5	64,5	69,5
40	-	44,5	49,5	54,5	59,5	64,5	69,5
50	-	-	49,5	54,5	59,5	64,5	69,5
63	-	-	52	57	62	67	72
80	-	-	56	61	66	71	76
100	-	-	66	71	76	81	86

DOUBLE ACTING MAGNETIC

1

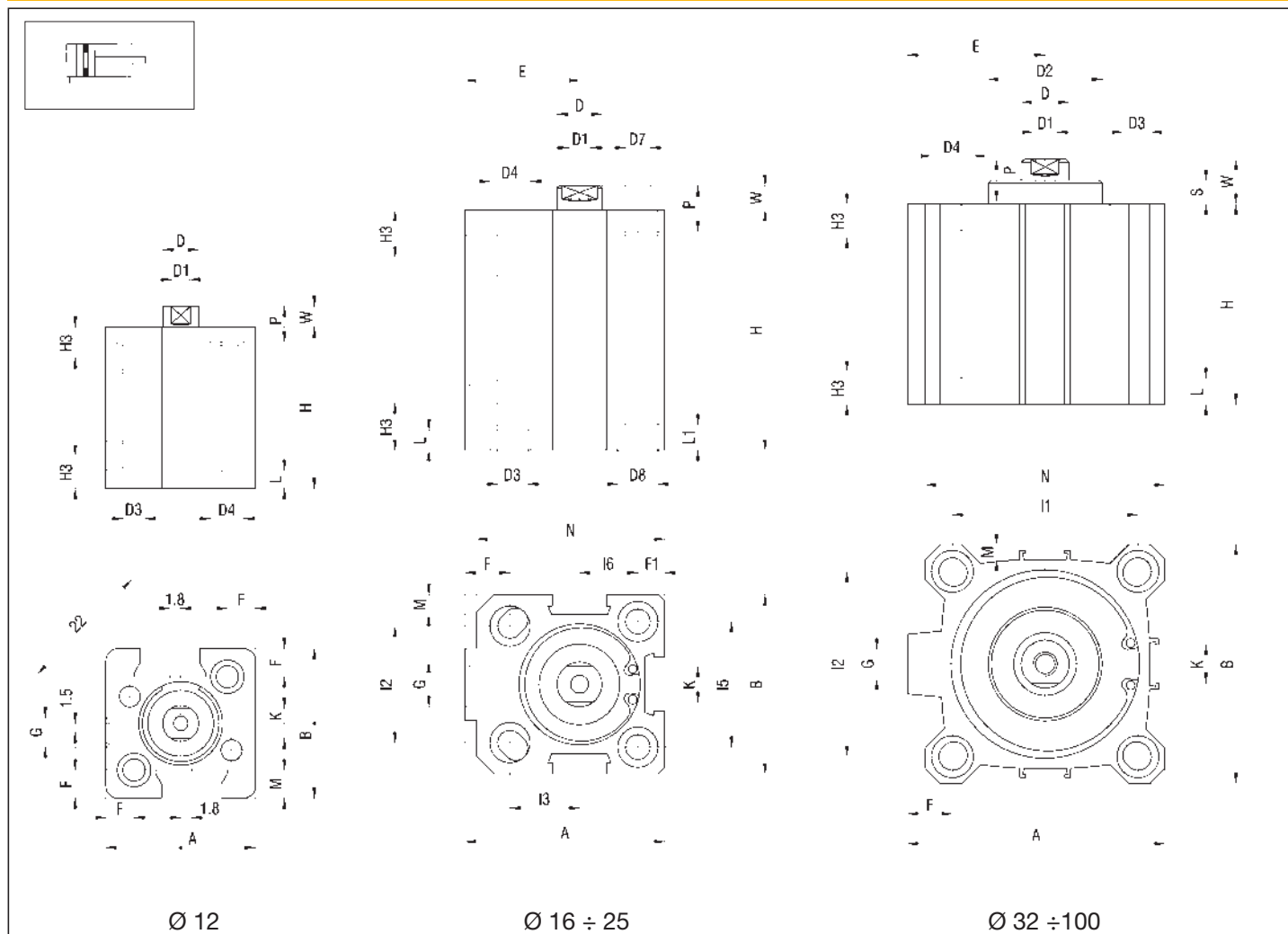

DIMENSIONS AND WEIGHTS

Ø	A	B	D	D1	D2	D3	D4	D7	D8	E	F	F1	G	H3	I1	I2	I3	I5	I6	K	L	L1	M	N	P	S	W	WEIGHT (g)	INCR. (g)
12	25	25	6	M3	-	3,7	5,6	-	-	-	4,7	-	M5	5,5	-	-	-	-	5	3,5	-	4,7	-	6	-	3,5	33,5	11,5	
16	34	30	8	M4	-	4,7	7,5	3,7	5,6	19	7	5	M5	8	-	18	12	20	10	6	4,6	3,5	4	32	8	-	4,5	74	16,5
20	40	36	10	M5	-	5,8	9	5,8	9	22	7	5,2	M5	8	-	20	15	25,5	12,7	8	5,7	5,7	5,7	38,5	10	-	5	106	24,5
25	44,5	40	10	M5	-	5,8	9	5,8	9	24,5	9	6	G1/8	10,5	-	26	15,5	28	14	8	5,7	5,7	4,5	42	10	-	5,5	145	32
32	51	46	12	M6	24,5	5,8	9	-	-	27	9	-	G1/8	11,5	36	32	-	-	10	5,7	-	4	48	12	5	11	172	36	
40	58	55	12	M6	28	5,8	9	-	-	30,5	9,5	-	G1/8	11	42	42	-	-	10	5,7	-	4	55	12	6	12,5	225	40	
50	70	65	16	M8	34	6,8	11	-	-	37,5	12,5	-	G1/8	11,5	50	50	-	-	13	6,8	-	4	65	12	6	13,5	359	63	
63	86	80	16	M8	38,5	9	14	-	-	46	15	-	G1/8	11	62	62	-	-	13	8,8	-	5	80	14	7	15	552	70	
80	105	100	20	M10	44	9	14	-	-	55	14	-	G1/4	14	82	82	-	-	17	9	-	6	100	15	8	18	1072	105	
100	131	124	25	M12	56	11	17,2	-	-	69	17,5	-	G1/4	16	103	103	-	-	22	11	-	7,5	124	20	10	20,5	1920	160	

"H" DIMENSION

Ø	STROKE (mm)														
	5	10	15	20	25	30	40	50	60	80	100	125	160	200	250
12	32	37	42	47	52	57	-	-	-	-	-	-	-	-	-
16	37	42	47	52	63	68	78	88	98	118	138	-	-	-	-
20	37	42	47	52	63	68	78	88	98	118	138	163	-	-	-
25	43,5	48,5	53,5	58,5	64,5	69,5	79,5	89,5	99,5	119,5	139,5	164,5	-	-	-
32	44,5	49,5	54,5	59,5	64,5	69,5	79,5	89,5	99,5	119,5	139,5	164,5	199,5	-	-
40	44,5	49,5	54,5	59,5	64,5	69,5	79,5	89,5	99,5	119,5	139,5	164,5	199,5	-	-
50	-	49,5	54,5	59,5	64,5	69,5	79,5	89,5	99,5	119,5	139,5	164,5	199,5	239,5	-
63	-	52	57	62	67	72	82	92	102	122	142	167	202	242	-
80	-	56	61	66	71	76	86	96	106	126	146	171	206	246	296
100	-	66	71	76	81	86	96	106	116	136	156	181	216	256	306

SINGLE ACTING, EXTENDED ROD AND SINGLE ACTING MAGNETIC, EXTENDED ROD

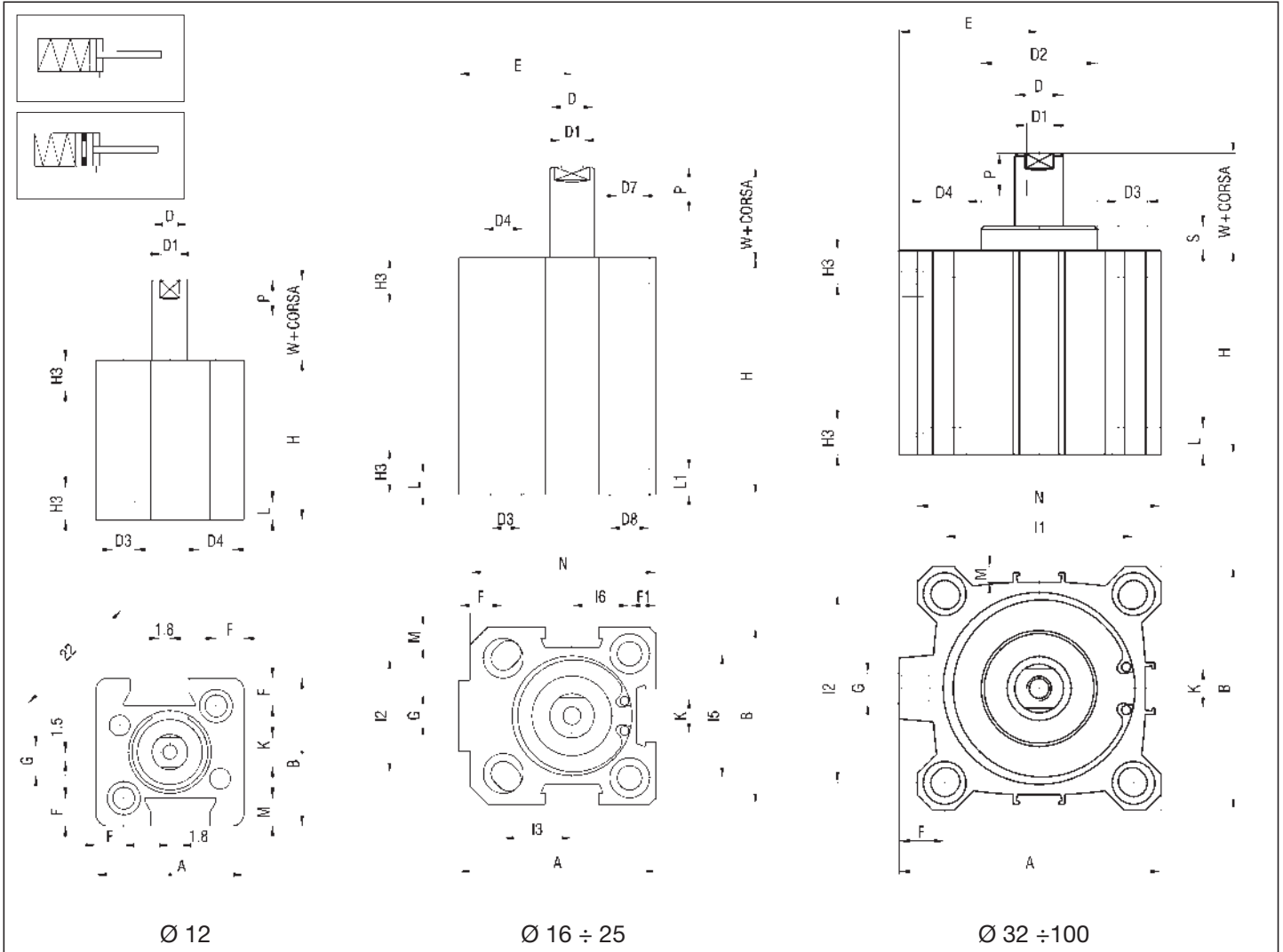

DIMENSIONS AND WEIGHTS

Ø	A	B	D	D1	D2	D3	D4	D7	D8	E	F	F1	G	H3	I1	I2	I3	I5	I6	K	L	L1	M	N	P	S	W	WEIGHT (g)	INCR. (g) x10 mm
12	25	25	6	M3	-	3,7	5,6	-	-	-	4,7	-	M5	5,5	-	-	-	-	-	5	3,5	-	4,7	-	6	-	3,5	33,5	11,5
16	34	30	8	M4	-	4,7	7,5	3,7	5,6	19	7	5	M5	8	-	18	12	20	10	6	4,6	3,5	4	32	8	-	4,5	74	16,5
20	40	36	10	M5	-	5,8	9	5,8	9	22	7	5,2	M5	8	-	20	15	25,5	12,7	8	5,7	5,7	5,7	38,5	10	-	4,5	106	24,5
25	44,5	40	10	M5	-	5,8	9	5,8	9	24,5	9	6	G 1/8	10,5	-	26	15,5	28	14	8	5,7	5,7	4,5	42	10	-	5,5	145	32
32	51	46	12	M6	24,5	5,8	9	-	-	27	9	-	G 1/8	11,5	36	32	-	-	-	10	5,7	-	4	48	12	5	11	172	36
40	58	55	12	M6	28	5,8	9	-	-	30,5	9,5	-	G 1/8	11	42	42	-	-	-	10	5,7	-	4	55	12	6	12,5	225	40
50	70	65	16	M8	34	6,8	11	-	-	37,5	12,5	-	G 1/8	11,5	50	50	-	-	-	13	6,8	-	4	65	12	6	13,5	359	63
63	86	80	16	M8	38,5	9	14	-	-	46	15	-	G 1/8	11	62	62	-	-	-	13	8,8	-	5	80	14	8	15	552	70

"H" DIMENSION

Ø	STROKE (mm)						
	5	10	15	20	25	30	
12	-	22	27	-	-	-	
-	12 magn	32	37	-	-	-	
16	16 magn	37	42	47	-	-	
20	20 magn	37	42	47	63	68	
25	25 magn	43,5	48,5	53,5	64,5	69,5	
32	32 magn	44,5	49,5	54,5	64,5	69,5	
40	40 magn	-	49,5	54,5	59,5	64,5	
50	50 magn	-	49,5	54,5	59,5	64,5	
63	63 magn	-	52	57	62	67	

1

DOUBLE ACTING, THROUGH ROD AND DOUBLE ACTING MAGNETIC, THROUGH ROD

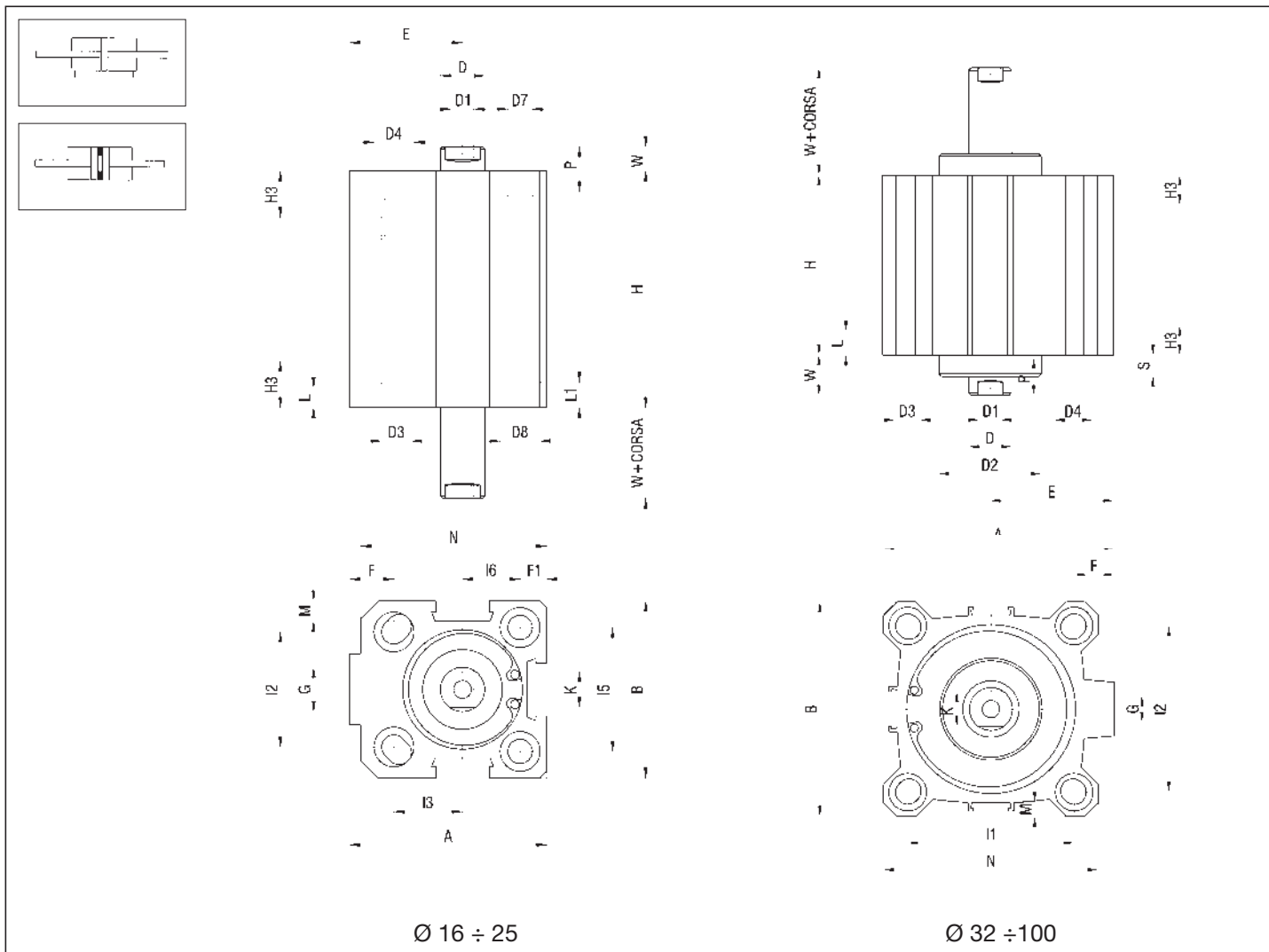

DIMENSIONS AND WEIGHTS

Ø	A	B	D	D1	D2	D3	D4	D7	D8	E	F	F1	G	H3	I1	I2	I3	I5	I6	K	L	L1	M	N	P	S	W	WEIGHT (g) x 10mm	INCR. (g)
16	34	30	8	M4	-	4,7	7,5	3,7	5,6	19	7	5	M5	8	-	18	12	20	10	6	4,6	3,5	4	32	8	-	4,5	130	19
20	40	36	10	M5	-	5,8	9	5,8	9	22	7	5,2	M5	8	-	20	15	25,5	12,7	8	5,7	5,7	5,7	38,5	10	-	4,5	150	28
25	44,5	40	10	M5	-	5,8	9	5,8	9	24,5	9	6	G 1/8	10,5	-	26	15,5	28	14	8	5,7	5,7	4,5	42	10	-	5,5	185	35,5
32	51	46	12	M6	24,5	5,8	9	-	-	27	9	-	G 1/8	11,5	36	32	-	-	-	10	5,7	-	4	48	12	5	11	282	39,5
40	58	55	12	M6	28	5,8	9	-	-	30,5	9,5	-	G 1/8	11	42	42	-	-	-	10	5,7	-	4	55	12	6	12,5	366	43,5
50	70	65	16	M8	34	6,8	11	-	-	37,5	12,5	-	G 1/8	11,5	50	50	-	-	-	13	6,8	-	4	65	12	6	13,5	521	68
63	86	80	16	M8	38,5	9	14	-	-	46	15	-	G 1/8	11	62	62	-	-	-	13	8,8	-	5	80	14	8	15	717	75
80	105	100	20	M10	44	9	14	-	-	55	14	-	G 1/4	14	82	82	-	-	-	17	9	-	6	100	15	10	18	1434	114
100	131	124	25	M12	56	11	17,2	-	-	69	17,5	-	G 1/4	16	103	103	-	-	-	22	11	-	7,5	124	20	10,5	20,5	2435	174

"H" DIMENSION

Ø	STROKE (mm)															
	5	10	15	20	25	30	40	50	60	80	100	125	160	200	250	
16	37	42	47	52	63	68	78	88	98	118	138	-	-	-	-	
20	37	42	47	52	63	68	78	88	98	118	138	163	-	-	-	
25	43,5	48,5	53,5	58,5	64,5	69,5	79,5	89,5	99,5	119,5	139,5	164,5	-	-	-	
32	44,5	49,5	54,5	59,5	64,5	69,5	79,5	89,5	99,5	119,5	139,5	164,5	199,5	-	-	
40	44,5	49,5	54,5	59,5	64,5	69,5	79,5	89,5	99,5	119,5	139,5	164,5	199,5	-	-	
50	-	49,5	54,5	59,5	64,5	69,5	79,5	89,5	99,5	119,5	139,5	164,5	199,5	239,5	-	
63	-	52	57	62	67	72	82	92	102	122	142	167	202	242	-	
80	-	56	61	66	71	76	86	96	106	126	146	171	206	246	296	
100	-	66	71	76	81	86	96	106	116	136	156	181	216	256	306	

NON ROTATING DOUBLE ACTING AND NON ROTATING DOUBLE ACTING MAGNETIC

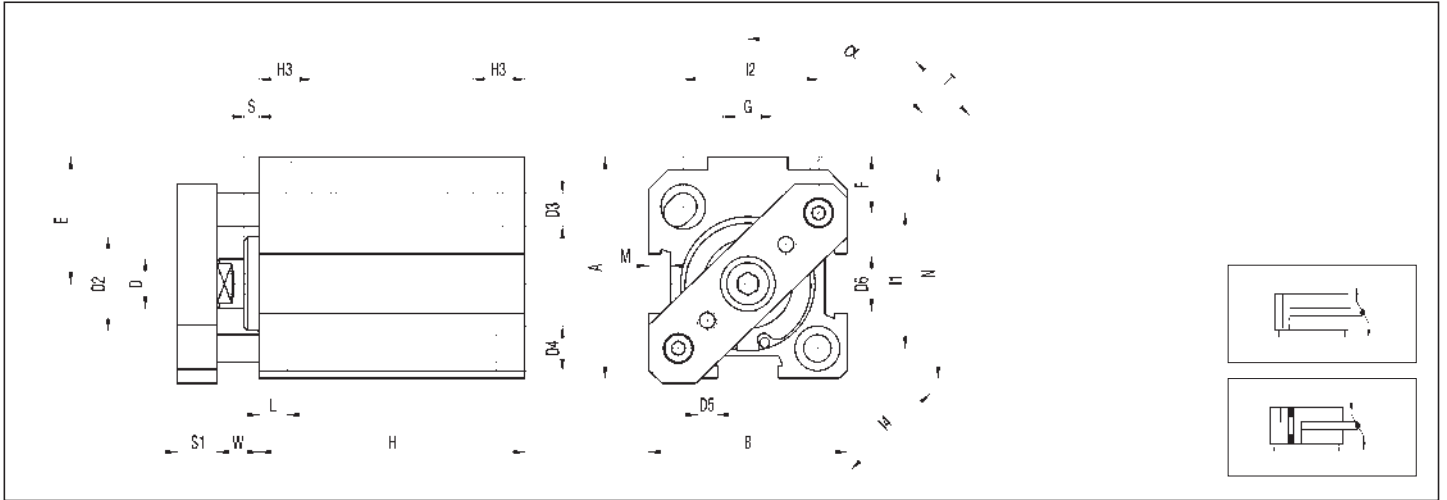

DIMENSIONS AND WEIGHTS

Ø	A	B	α	D	D2	D3	D4	D5	D6	E	F	G	H3	I1	I2	I4	L	M	N	S	S1	T	W	WEIGHT (g)	INCR. (g) x10 mm
20	40	36	45°	10	-	5,8	9,2	M4	11	22	9,3	M5	8	25,5	25,5	20	5,7	5,7	38,5	-	8	15	4,5	150	28
25	44,5	40	45°	10	-	5,8	9,2	M4	11	24,5	10,5	G1/8	11	28	28	22	5,7	4,5	42	-	8	15	5,5	185	35,5
32	51	46	41,5°	12	24,5	5,8	9,2	M5	17	27	9	G1/8	11,5	36	32	28	5,7	4	48	5	10	20	11	282	39,5
40	58	55	45°	12	28	5,8	9,2	M5	17	30,5	9,5	G1/8	11,5	42	42	33	5,7	4	55	6	10	20	12,5	366	43,5
50	70	65	45°	16	34	6,8	11	M6	22	37,5	12,5	G1/8	11,5	50	50	42	6,8	4	65	6	12	30	13,5	521	68
63	86	80	45°	16	38,5	9	14	M6	22	46	15	G1/8	12	62	62	50	8,8	5	80	8	12	30	15	717	75
80	105	100	45°	20	44	9	14	M8	28	55	14	G1/4	14	82	82	65	9	6	100	10	14	50	18	1434	114
100	131	124	45°	25	56	11	17,2	M10	30	69	17,5	G1/4	16	103	103	80	11	7,5	124	10,5	14	50	20,5	2435	174

"H" DIMENSION

Ø	STROKE (mm)													
	5	10	15	20	25	30	40	50	60	80	100	125	160	
20	37	42	47	52	63	68	78	88	98	118	138	-	-	
25	43,5	48,5	53,5	58,5	64,5	69,5	79,5	89,5	99,5	119,5	139,5	-	-	
32	44,5	49,5	54,5	59,5	64,5	69,5	79,5	89,5	99,5	119,5	139,5	-	-	
40	44,5	49,5	54,5	59,5	64,5	69,5	79,5	89,5	99,5	119,5	139,5	-	-	
50	-	49,5	54,5	59,5	64,5	69,5	79,5	89,5	99,5	119,5	139,5	164,5	-	
63	-	52	57	62	67	72	82	92	102	122	142	167	202	
80	-	56	61	66	71	76	86	96	106	126	146	171	206	
100	-	66	71	76	81	86	96	106	116	136	156	181	216	

MALE HINGE MOUNTING

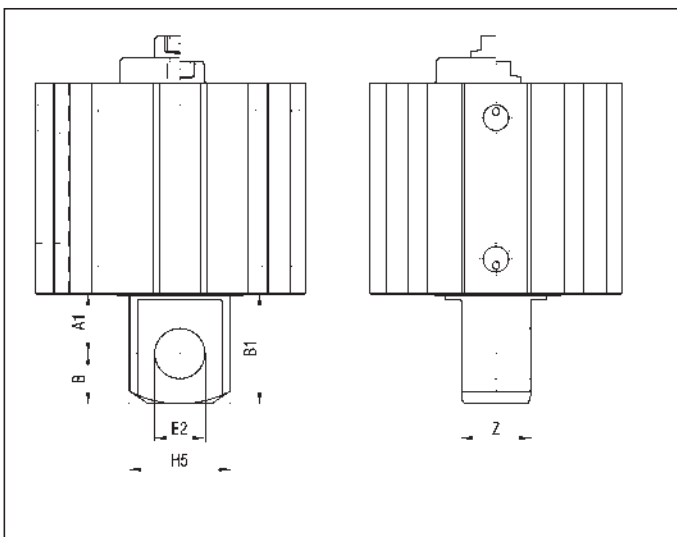

DIMENSIONS

Ø	A1	B	E2 H8	H5	Z	B1
16	8	6	6	12	7	14
20	10	8	8	16	9	18
25	10	8	8	16	9	18
32	13	10	10	20	14	23
40	15	12	12	24	16	27
50	15	12	12	24	17	27
63	19	16	16	32	22	35
80	19	16	16	32	22	35
100	23	20	20	40	26	43

1

FEET (pair) - ALUMINIUM - B/PB Ø

Ø	A2	B2	C	D9	E1	F2	I6
16	5	10	10	3,5	17	5	30
20	5	10	10	3,5	18	5	40
25	6	12	12	5,5	20	7,5	45
32	6	12	12	5,5	24	5	50
40	6	12	12	5,5	27,5	5	60
50	7,5	15	15	6,5	32,5	5	70
63	7,5	15	15	8,5	40	7,5	85
80	10	20	20	8,5	50	20	60
100	10	20	20	10,5	62	22	80

Ø	L2	M1	N1	R	WEIGHT (g)
16	H*+10	2,4	40	M3	10
20	H*+10	4	50	M5	10,1
25	H*+12	4	60	M5	20,4
32	H*+12	4	60	M5	20,4
40	H*+12	4	70	M5	24,7
50	H*+15	5	80	M6	44,7
63	H*+15	6,5	100	M8	53
80	H*+20	6,5	100	M8	99
100	H*+20	8	124	M10	120

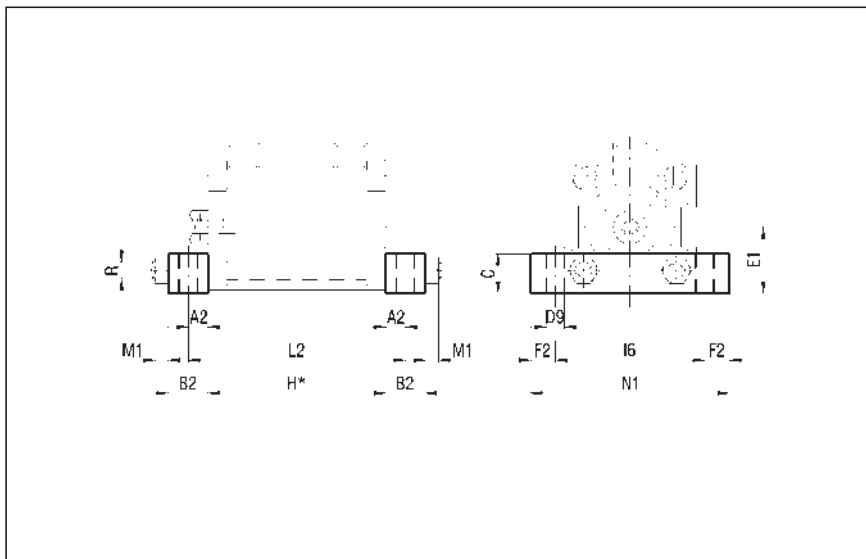

*DIMENSION "H" IS OBTAINABLE FROM THE TABLES OF THE SINGLE VERSION

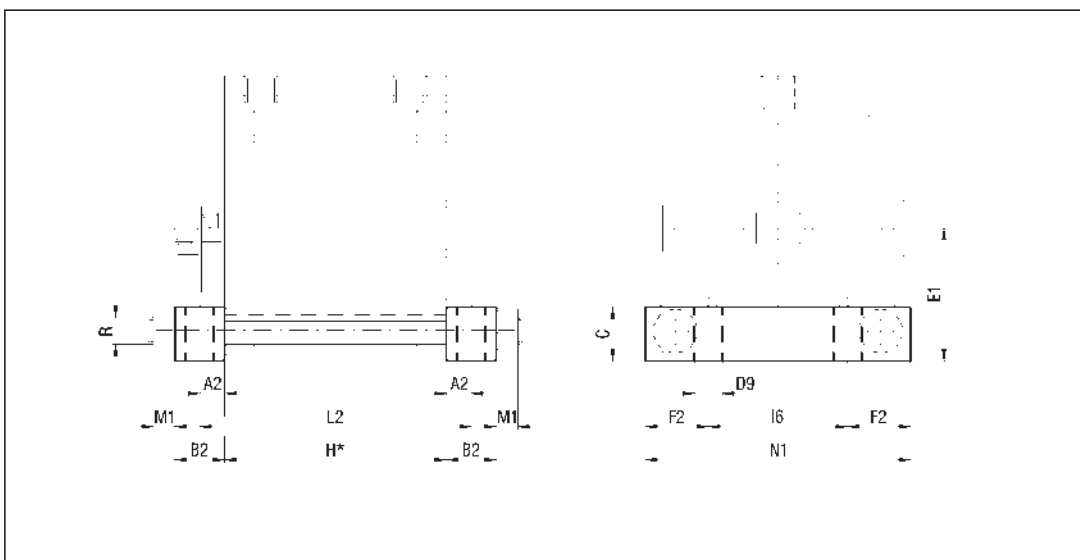

ROD NIPPLE WITH THREAD TO ISO STANDARD - STEEL - NB Ø

Ø	D	D1	A	B	C	WEIGHT (g)
12	M6	M3	16	6,5	22,5	3
16	M6	M4	15	8	23	3,2
20-25	M8	M5	20	10	30	7,2
32-40	M10x1,25	M6	22	12	34	13,1
50-63	M12x1,25	M8	24	14	38	23
G50-63	M16x1,5	M8	32	14	46	47,6
80	M16x1,5	M10	32	15	47	50,5
100	M20x1,5	M12	40	20	60	101

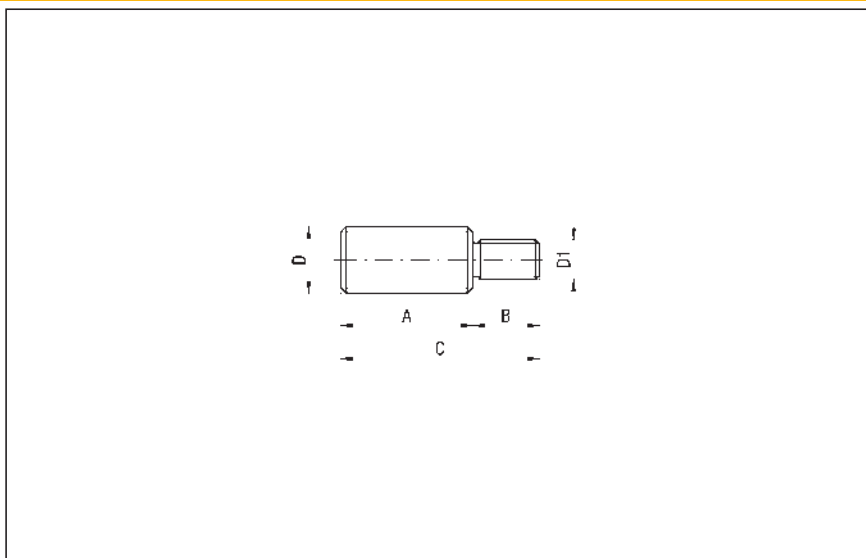

DESCRIPTION

Compact guided cylinders series "BG" have reduced dimensions and high precision movement. These cylinders assure great strength to transversal forces thanks to stout bars guided on bushings or sleeves. Cylinders series "BG" are double acting and they have the magnetic piston type and the steel plate as standard, so they can be supplied with magnetic sensors.

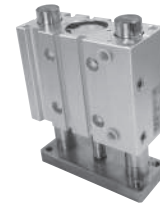

MATERIALS

End caps	Anodized aluminium alloy
Body	Anodized aluminium alloy
Piston rod	Ø 16 ÷ 25 : AISI 303 stainless steel Ø 32 ÷ 63 : C45 chromium-plated steel
Piston	Aluminium alloy with magnet
Guide bars	C45 chromium-plated steel (bushings sliding type) Hardened steel (recirculating ball bearing sleeves sliding type)
Plate	Nickel-plated steel Anodized aluminium alloy
Bushings	Self-lubricating sintered bronze with wiper ring No.2 pcs. for strokes 20 ÷ 50 mm; No.4 pcs. for strokes 75 ÷ 200 mm
Sleeves	Recirculating ball bearings with wiper ring No.2 pcs. for strokes 20 ÷ 50 mm; No.4 pcs. for strokes 75 ÷ 200 mm
Seals	Polyurethane

TECHNICAL DATA

Operating pressure	1 ÷ 10 bar
Working temperature	0 ÷ +80 °C (-20 °C with dry air)
Fluid	Filtered, unlubricated or continuous lubricated compressed air
Bore	Ø 16, 20, 25, 32, 40, 50, 63
Port size	Ø 16 = M 5 Ø 20 ÷ 40 = G 1/8 Ø 50 = G 1/4
Standard strokes (mm)	Ø 16 = 10, 20, 30, 40, 50, 75, 100 Ø 20 = 20, 30, 40, 50, 75, 100, 125, 150, 175, 200 Ø 25 = 20, 25, 30, 40, 50, 75, 100, 125, 150, 175, 200 Ø 32 ÷ 63 = 25, 50, 75, 100, 125, 150, 175, 200

ORDER KEY

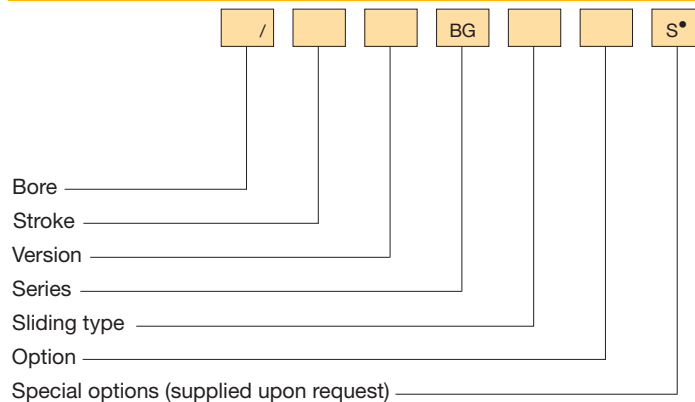

P.S.: *Magnetic sensors* FM 100 (see chapter magnetic sensors from page 1.93)
• See technical data on page 0.12

TECHNICAL DATA

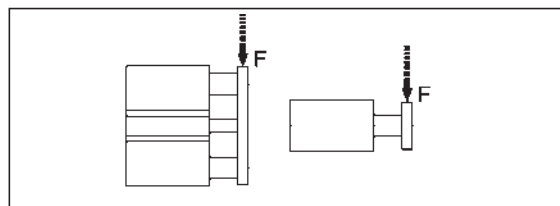

MAXIMUM PERMISSIBLE TRANSVERSE FORCE F (N)

Ø	Sliding type	STROKE (mm)							
		10	20	25	30	40	50	75	100
16	B	41	32	-	26	23	20	27	22
	M	44	34	-	27	23	21	27	22
20	B	-	53	-	45	38	34	52	42
	M	-	62	-	50	42	36	53	44
25	B	-	93	-	78	68	60	81	67
	M	-	94	-	79	68	60	59	51
32	B	-	-	168	-	-	131	163	138
	M	-	-	84	-	-	58	270	213
40	B	-	-	168	-	-	131	163	138
	M	-	-	92	-	-	64	270	213
50	B	-	-	240	-	-	189	243	208
	M	-	-	117	-	-	81	370	312
63	B	-	-	250	-	-	190	265	227
	M	-	-	117	-	-	81	370	312

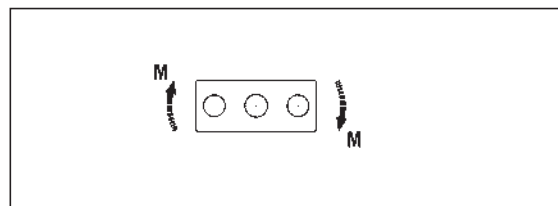

MAXIMUM PERMISSIBLE TORQUE M (Nm)

Ø	Sliding type	STROKE (mm)							
		10	20	25	30	40	50	75	100
16	B	0,65	0,51	-	0,42	0,36	0,32	-	-
	M	0,83	0,65	-	0,52	0,44	0,40	-	-
20	B	-	0,99	-	0,84	0,71	0,64	0,97	0,78
	M	-	1,20	-	0,96	0,81	0,69	1,02	0,85
25	B	-	1,98	-	1,67	1,45	1,28	1,73	1,43
	M	-	2,00	-	1,69	1,45	1,28	1,26	1,09
32	B	-	-	4,10	-	-	3,19	3,97	3,36
	M	-	-	2,04	-	-	1,41	6,58	5,19
40	B	-	-	4,51	-	-	3,51	4,38	3,70
	M	-	-	2,47	-	-	1,72	7,25	5,72
50	B	-	-	6,60	-	-	5,19	6,68	5,72
	M	-	-	3,22	-	-	2,22	10,17	8,58
63	B	-	-	6,60	-	-	5,19	6,68	5,72
	M	-	-	3,22	-	-	2,22	10,17	8,58

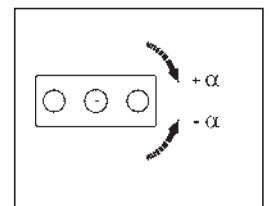

ANTI-ROLL ACCURACY α

Ø	Sliding type	
	B	M
16	±0,08°	±0,10°
20	±0,07°	±0,09°
25	±0,07°	±0,09°
32	±0,06°	±0,08°
40	±0,06°	±0,08°
50	±0,05°	±0,06°
63	±0,05°	±0,06°

B - Bushing
M - Sleeves

BG COMPACT GUIDED CYLINDER

1

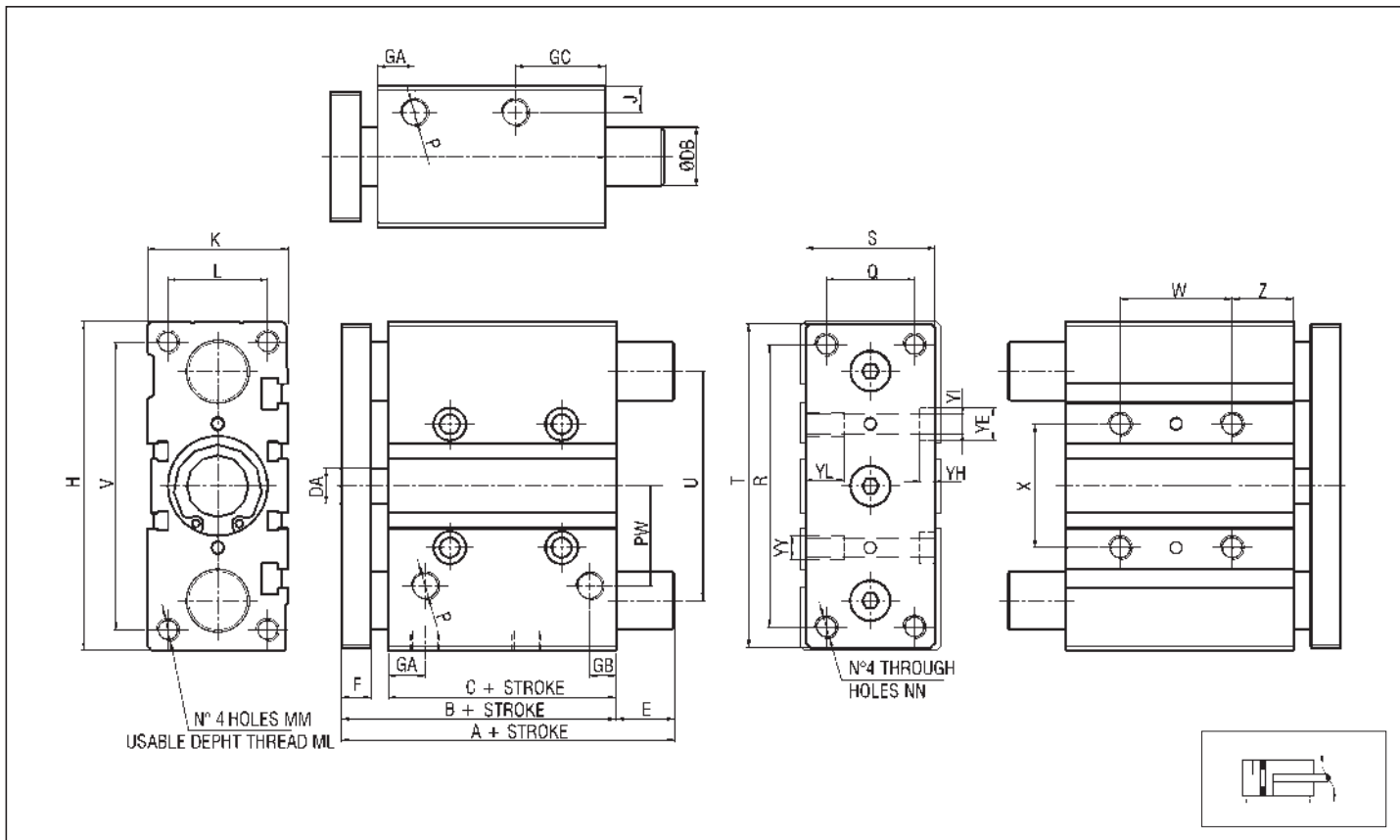

DIMENSIONS AND WEIGHTS BASIC CYLINDER

Ø	A (STROKES mm)				B	C	DA	DB	E (STROKES mm)		F	GA	GB	GC	H	J	L	K	MM	ML	NN	P
	10	20	25	50					125	200												
16	46 (10 ÷ 50)	64,5 (75 ÷ 100)	46	33	8	10	0 (10 ÷ 50)	18,5 (75 ÷ 100)	8	11	8	8	64	5	22	30	M5	12	M5	M5		
20	53 (20 ÷ 50)	84,5 (75 ÷ 200)	53	37	10	12	0 (20 ÷ 50)	31,5 (75 ÷ 200)	10	10,5	8,5	24,5	83	7,5	24	36	M5	13	M5	G1/8		
25	53,5 (20 ÷ 50)	84,5 (75 ÷ 200)	54	37,5	10	16	0 (20 ÷ 50)	31,5 (75 ÷ 200)	10	11,5	9	25	93	7,5	30	42	M6	15	M6	G1/8		
32	97 (25 ÷ 50)	107 (75 ÷ 200)	60	37,5	12	20	37,5 (25 ÷ 50)	42,5 (75 ÷ 200)	12	12,5	9	30,5	112	9	34	48	M8	20	M8	G1/8		
40	97 (25 ÷ 50)	107 (75 ÷ 200)	66	44	12	20	31 (25 ÷ 50)	36 (75 ÷ 200)	12	14	10	31	120	9	40	54	M8	20	M8	G1/8		
50	106,5 (25 ÷ 50)*	118 (75 ÷ 200)	72	44	16	25	34,5 (25 ÷ 50)*	46 (75 ÷ 200)	16	14	11	35	148	10,5	46	64	M10	22	M10	G1/4		
63	106,5 (25 ÷ 50)*	118 (75 ÷ 200)	77	49	16	25	29,5 (25 ÷ 50)*	41 (75 ÷ 200)	16	16,5	13,5	35	162	11	58	78	M10	22	M10	G1/4*		

Ø	PW	Q	R	S	T	U	V	W (STROKES mm)			X	YE	YH	YI	YL	YY	Z	WEIGHT (g) for STROKES (mm) with aluminium plate							
								10	20	25								30	40	50	75	100			
16	19	16	54	25	62	46	56	24 (10 ÷ 30)	44 (40 ÷ 100)	-	24	8	4,5	4,3	10	M5	5	300	350	-	400	450	500	700	850
20	20,5	18	70	30	81	54	72	24 (20 - 30)	44 (40 ÷ 100)	120 (125 ÷ 200)	28	9,5	5,5	5,6	12	M5	17	-	640	-	720	800	880	1200	1400
25	28,5	26	78	38	91	64	82	24 (20 - 30)	44 (40 ÷ 100)	120 (125 ÷ 200)	34	9,5	5,5	5,6	12	M6	17	-	850	-	950	1050	1150	1600	1850
32	34	30	96	44	110	78	98	24 (25)	48 (50 ÷ 100)	124 (125 ÷ 200)	42	11	7,5	6,6	16	M8	21	-	-	1500	-	-	1850	2500	2850
40	28,5	30	104	44	118	86	106	24 (25)	48 (50 ÷ 100)	124 (125 ÷ 200)	50	11	7,5	6,6	16	M8	22	-	-	1700	-	-	2100	2650	3050
50	47	40	130	60	146	110	130	24 (25)	48 (50 ÷ 100)	124 (125 ÷ 200)	66	14	9	8,6	20	M10	22	-	-	2700	-	-	3300	4100	4700
63	55	50	130	70	158	124	142	28 (25)	52 (50 ÷ 100)	128 (125 ÷ 200)	80	14	9	8,6	20	M10	24	-	-	3100	-	-	4218	4936	5655

* With sleeves: dimension "A" (stroke 50) = 114 for Ø 50 and 63; dimension "E" (stroke 50) = 42 for Ø 50 and 37 for Ø 63

SLOTS FIXING PLATE - STEEL - BG/PF Ø

Ø	A	B	C	D	CH	WEIGHT (g)
16	7	10	M4	3,5	1,5	2
20 - 25	8	15	M5	4	2	3,5
32 - 40	10	20	M6	5	2,5	7,5
50 - 63	13	25	M8	7	3	17

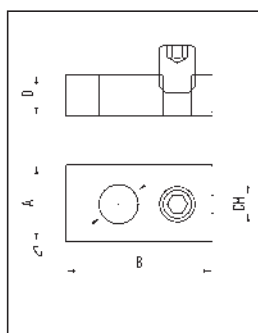

FIXING EXAMPLE

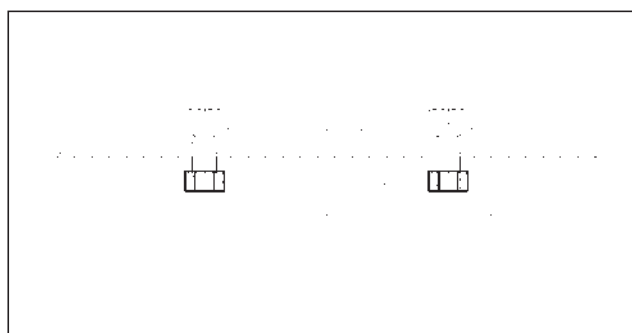

DESCRIPTION

Cylinders series "HB" are manufactured to be fixed on machine edges without the use of mountings. The end cap acts as a mounting device in the versions: hinge-mounted, screw-mounted, feet-mounted, front flange-mounted, rear flange-mounted. The double acting hinge-mounted versions and rear flange-mounted are available with reduced end caps. Cylinders series "HB" cannot be supplied with magnetic sensors.

TECHNICAL DATA

Operating pressure	1,5 ÷ 10 bar																			
Working temperature	0 ÷ +80 °C (-20 °C with dry air) 0 ÷ +150 °C with seals for high temperatures (-20 °C with dry air)																			
Fluid	Filtered, unlubricated or continuous lubricated compressed air																			
Versions	Double acting; Single acting front spring; Single acting rear spring; Through rod																			
Bore	Ø 20, 27, 35, 40, 50, 58, 70, 85, 100																			
Port size	Ø 20 ÷ 50 = G 1/8 Ø 58 ÷ 100 = G 1/4																			
Standard strokes (mm)	10, 15, 20, 30, 40, 50, 60, 70, 80, 90, 100, 150, 200, 250																			
Max. strokes double acting (mm)	Ø 20 - 27 = 1000; Ø 35 ÷ 50 = 1500; Ø 58 ÷ 100 = 2000																			
Maximum strokes single acting	<table border="1"> <tr> <td>Ø 20</td><td>27</td><td>35</td><td>40</td><td>50</td><td>58</td><td>70</td><td>85</td><td>100</td> </tr> <tr> <td>mm</td><td>20</td><td>25</td><td>35</td><td>60</td><td>70</td><td>60</td><td>70</td><td>90</td><td>100</td> </tr> </table>	Ø 20	27	35	40	50	58	70	85	100	mm	20	25	35	60	70	60	70	90	100
Ø 20	27	35	40	50	58	70	85	100												
mm	20	25	35	60	70	60	70	90	100											
Maximum strokes single acting (version "S") with spacers	<table border="1"> <tr> <td>Ø 20</td><td>27</td><td>35</td><td>40</td><td>50</td><td>58</td><td>70</td><td>85</td><td>100</td> </tr> <tr> <td>mm</td><td>60</td><td>75</td><td>105</td><td>180</td><td>210</td><td>180</td><td>210</td><td>270</td><td>300</td> </tr> </table>	Ø 20	27	35	40	50	58	70	85	100	mm	60	75	105	180	210	180	210	270	300
Ø 20	27	35	40	50	58	70	85	100												
mm	60	75	105	180	210	180	210	270	300											

MATERIALS

End caps	Aluminium alloy
Cylinder barrel	Ø 20 ÷ 100: Extruded tube, anodized aluminium alloy; Extruded tube, brass (supplied upon request)
Piston rod	C45 chromium-plated steel AISI 303 rolled stainless steel
End cap nut	Steel
Piston rod bearing	Bronze-iron 20%, sintered, self-lubricating
Piston guide shoe	Acetal resin
Piston	Aluminium alloy
Seals	NBR rubber Viton®
Springs	Springs steel

ORDER KEY

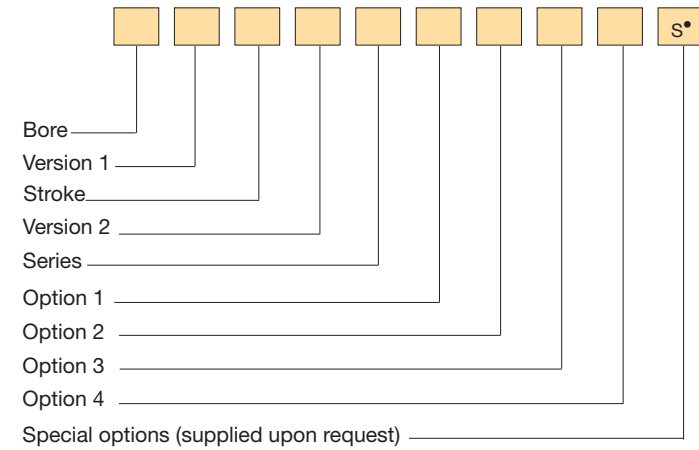

• See technical data on page 0.12

ORDER EXAMPLES

Basic cylinder Ø27, 25 mm stroke, single acting front spring, feet-mounted 27/25 SPB

Cylinder Ø20, through rod, 100 mm stroke, double acting, feet-mounted 20R100 DPB

Basic cylinder Ø58, 50 mm stroke, double acting, hinge-mounted, stainless steel piston rod, brass cylinder barrel 58/50 DVB 1 4

Basic cylinder Ø35, 70 mm stroke, double acting, hinge-mounted, reduced end cap 35/70 DCBC



SPRING THEORETICAL TRACTIVE FORCE

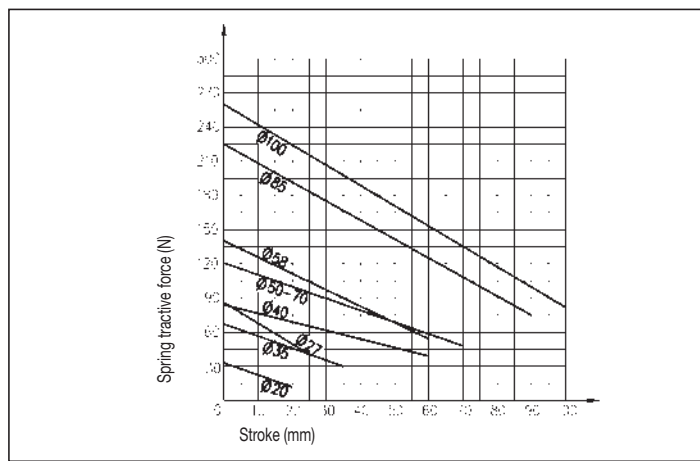

VERSION 1

/ Basic cylinder R Through rod*

VERSION 2

D Double acting Y Single acting front spring**
S Single acting front spring

SERIES

CB Hinge-mounted FAB Front flange-mounted
VB Screw-mounted FPB Rear flange-mounted
PB Feet-mounted

OPTION 1

C Reduced end cap***

OPTION 2

1 Stainless steel piston rod 3 Stainless steel piston rod and seals for high temperatures
2 Seals for high temperatures

OPTION 3

4 Brass cylinder barrel

OPTION 4

5 Rod wipers

* Series "FPB" excluded
** Dimensions are different from the versions "D" and "S"
*** Supplied only with series "DCB", "YCB", "DFPB", "YFPB" and with the version "R" of series "DFAB" and "DVB"

SPARE PARTS

SEALS KIT			
NBR	Ø/SG/HB	For high temperatures	Ø/SG/HB2
Through rod, NBR	Ø/SG/R/HB	Through rod, for high temperatures	Ø/SG/R/HB2

1

BASIC CYLINDER HINGE-MOUNTED - CB

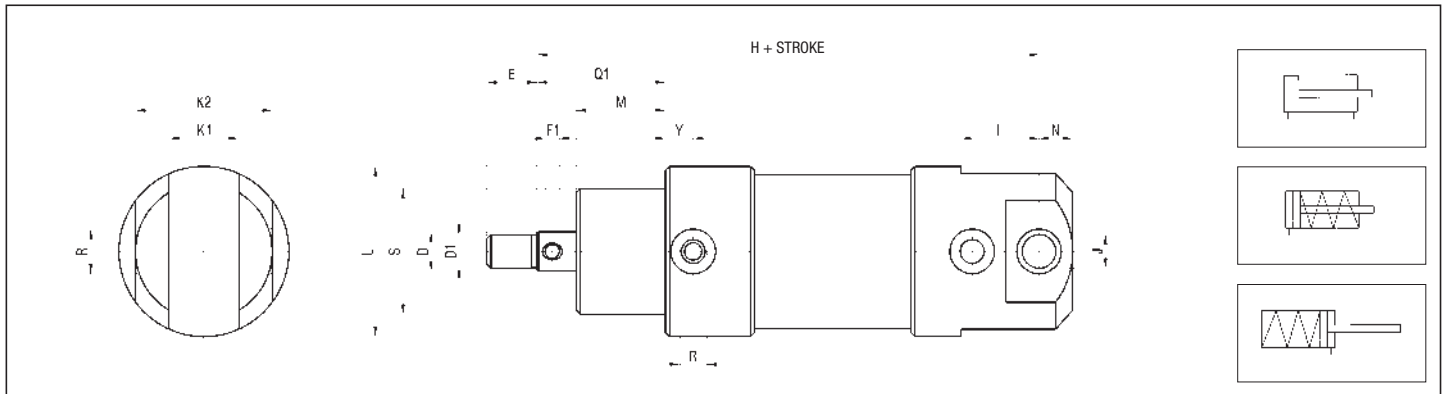

REDUCED END CAP

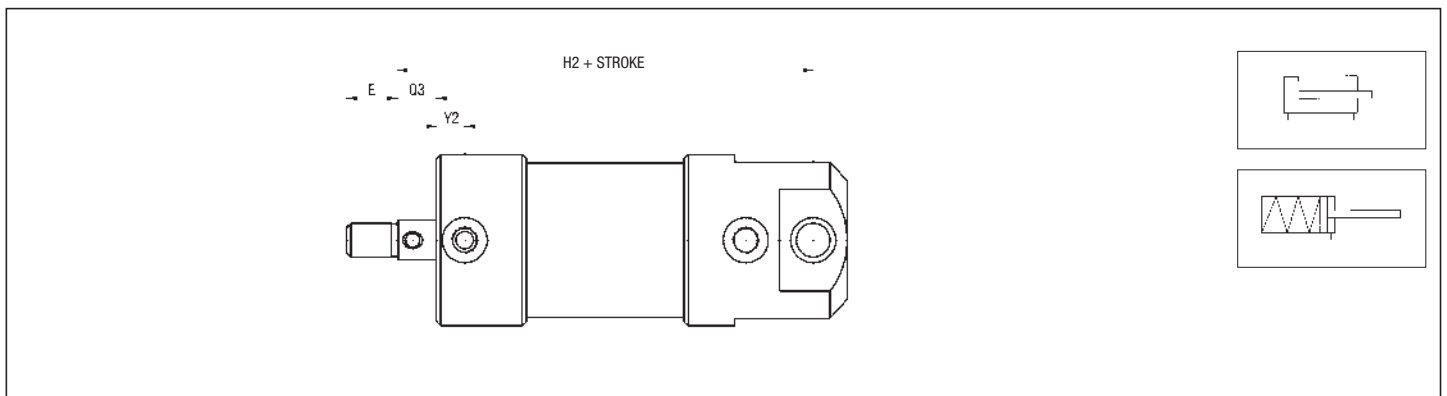

DIMENSIONS AND WEIGHTS BASIC CYLINDER CB

Ø	D	D1	E	F1	H	H2	I	J H8	K1 0/+0,2	K2 0/-0,2	L	M	N	Q1	Q3	R	S	Y	Y2	WEIGHT (g)	INCREM. (g) every 10 mm
20	8	M6	9	3	85	72	10	5	8	22	30	16	6	24	8	G 1/8	24	10	11,5	200	15
27	10	M8	12	4	96	76	21	6	9	25	35	20	7	30	10	G 1/8	28	9,5	11,5	289	20
35	12	M10	15	4	106	84	23	8	12	32	45	24	9	36	12	G 1/8	32	9,5	10	396	32
40	12	M10	15	4	121	90	26	10	18	40	50	32	10	44	12	G 1/8	36	10	10	503	35
50	14	M12	18	5	130	101	28	12	25	49	61	32	12	46	14	G 1/8	42	10	10	793	44
58	16	M14	21	5	140	110	33	14	26	54	70	32	14	48	16	G 1/4	45	12	14	1181	53
70	18	M16	24	5	151	122	35	16	35	67	82	35	16	53	18	G 1/4	50	14	16	1474	64
85	20	M18	27	6	168	128	36	18	40	76	98	44,5	18	64,5	20	G 1/4	60	12,5	14	2033	89
100	24	M20	30	6	191	142	45	20	40	80	114	50	20	74	24	G 1/4	70	14	19	3250	110

ACCESSORIES

PIVOT FOR FEMALE REAR HINGE - STEEL - HB/SEC Ø

Ø	BU	EK f7	EL	WEIGHT (g)
20	28	5	23	4,5
27	31	6	26	7
35	38	8	33	15
40	47	10	41	29
50	56	12	50	50
58	62	14	55	76
70	75	16	68	118
85	84	18	77	168
100	88	20	81	217

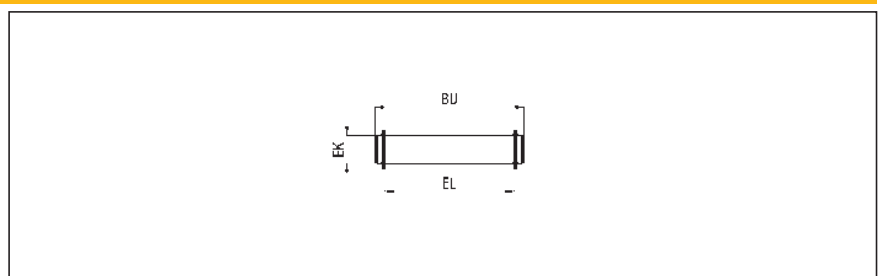

BASIC CYLINDER SCREW-MOUNTED - VB

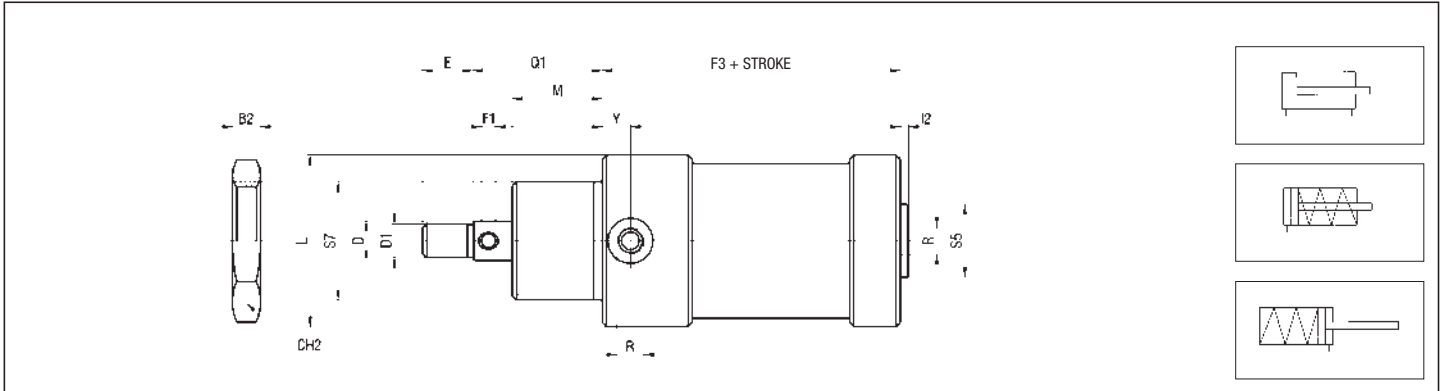

P.S.: End cap nut (HB/DT Ø) supplied as standard. Contact the commercial office for further nuts.

THROUGH ROD

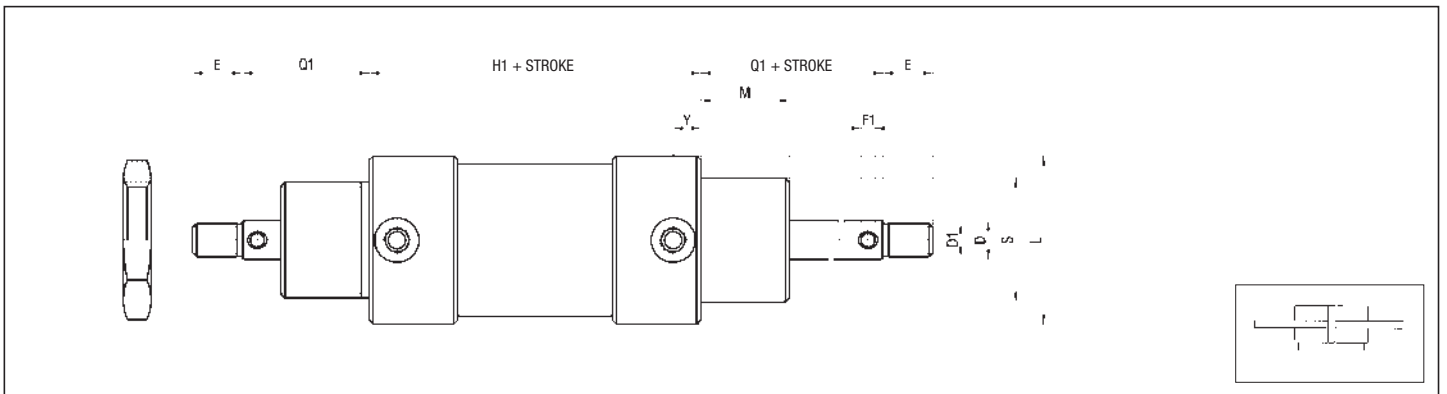

P.S.: End cap nut (HB/DT Ø) supplied as standard. Contact the commercial office for further nuts.

THROUGH ROD, REDUCED END CAP

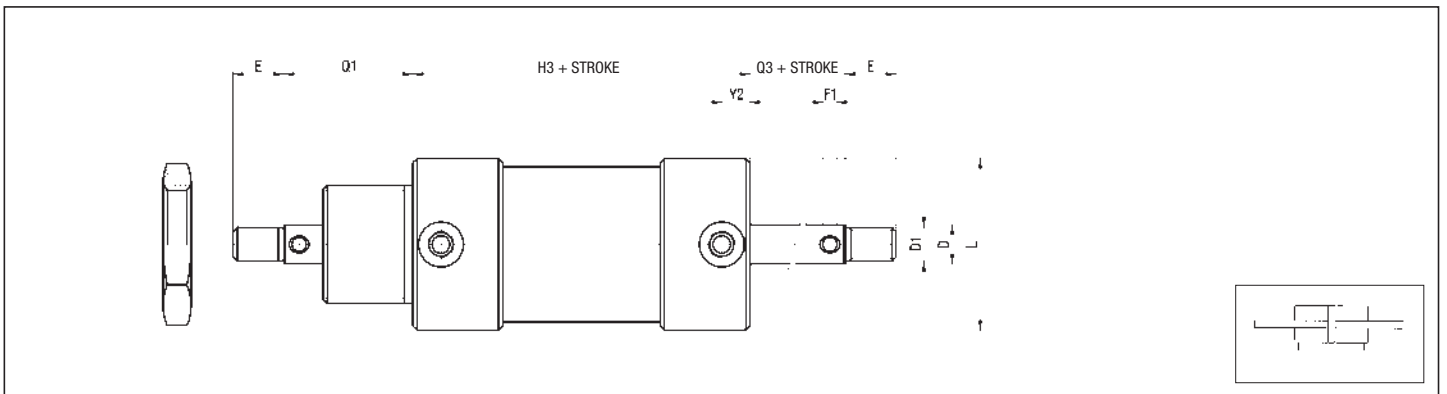

P.S.: End cap nut (HB/DT Ø) supplied as standard. Contact the commercial office for further nuts.

DIMENSIONS AND WEIGHTS BASIC CYLINDER VB

Ø	B2	CH2	D	D1	E	F1	F3	H1	H3	I2	L	M	Q1	Q3	R	S	S5	S7	Y	Y2	WEIGHT (g)	INCREM. (g) every 10 mm
20	5	32	8	M6	9	3	41	58	61	3,5	30	16	24	8	G 1/8	24	14	M24x2	10	11,5	129	15
27	6	35	10	M8	12	4	45,5	60,5	62,5	3,5	35	20	30	10	G 1/8	28	14	M28x2	9,5	11,5	160	20
35	7	40	12	M10	15	4	47,5	61,5	63,5	3,5	45	24	36	12	G 1/8	32	18	M32x2	9,5	10	299,5	32
40	8	45	12	M10	15	4	51	68	69	3	50	32	44	12	G 1/8	36	24	M36x3	10	10	416	35
50	10	50	14	M12	18	5	56	70	73	3	61	32	46	14	G 1/8	42	26	M42x3	10	10	691	44
58	10	55	16	M14	21	5	59	75	77	4	70	32	48	16	G 1/4	45	30	M45x3	12	14	1028	53
70	10	60	18	M16	24	5	63	80	86	4	82	35	53	18	G 1/4	50	30	M50x3	14	16	1388	64
85	12	70	20	M18	27	6	67,5	84	88,5	4	98	44,5	64,5	20	G 1/4	60	40	M60x4	12,5	14	2024	89
100	14	85	24	M20	30	6	72	89	90	4	114	50	74	24	G 1/4	70	40	M70x4	14	19	3060	110

1

BASIC CYLINDER FEET-MOUNTED - PB

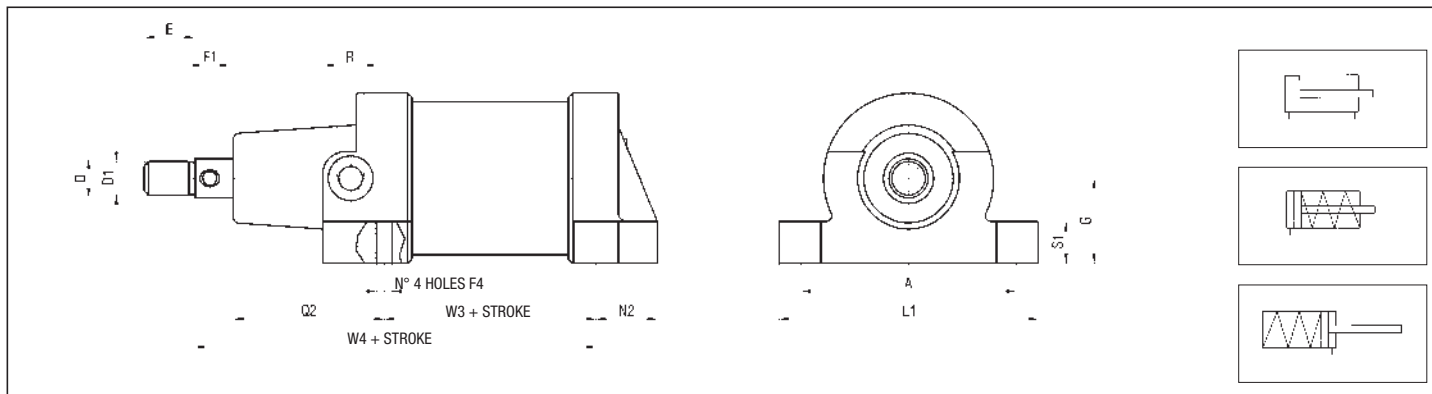

THROUGH ROD

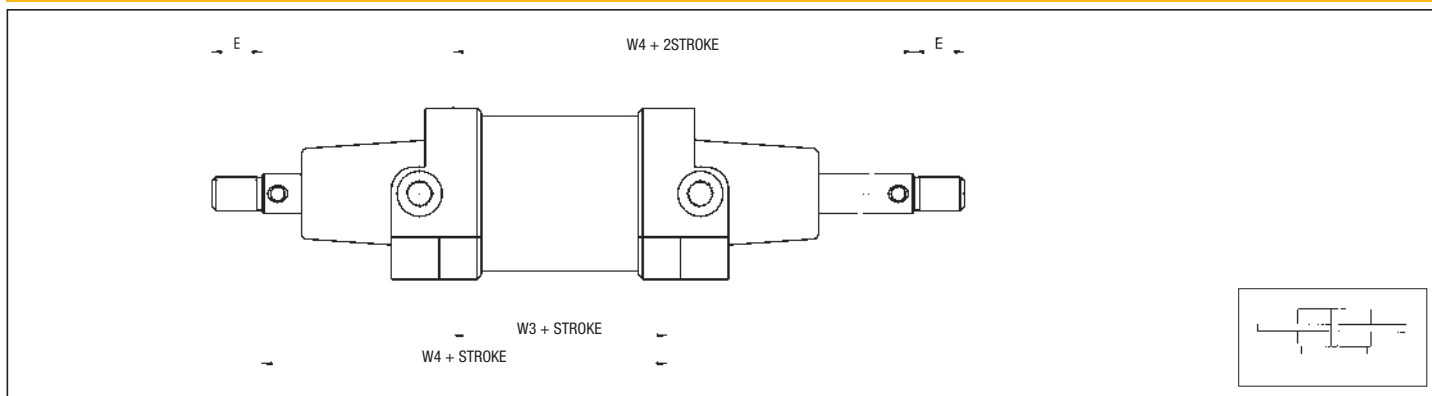

DIMENSIONS AND WEIGHTS BASIC CYLINDER PB

Ø	A	D	D1	E	F1	F4	G	L1	N2	Q2	R	S1	W3	W4	WEIGHT (g)	INCREMENT (g) every 10 mm
20	42	8	M6	9	3	4,25	17	52	13	36	G 1/8	8	18	62	181	15
27	45	10	M8	12	4	4,5	19,5	55	17	40	G 1/8	10	20	70	269	20
35	57	12	M10	15	4	5,5	22,5	69	17	44	G 1/8	12	21	77	359	32
40	64	12	M10	15	4	5,5	25	78	22	56	G 1/8	14	20	88	502	35
50	77	14	M12	18	5	5,5	30,5	93	22	54	G 1/8	16	26	94	743	44
58	86	16	M14	21	5	6,5	35	102	25	56	G 1/4	16	27	99	996	53
70	100	18	M16	24	5	6,5	41	118	26	61	G 1/4	18	28	107	1363	64
85	118	20	M18	27	6	8,5	49	138	27	72	G 1/4	20	30	122	2043	89
100	136	24	M20	30	6	8,5	57	158	28	76	G 1/4	22	33	133	3019	110

BASIC CYLINDER FRONT FLANGE-MOUNTED - FAB

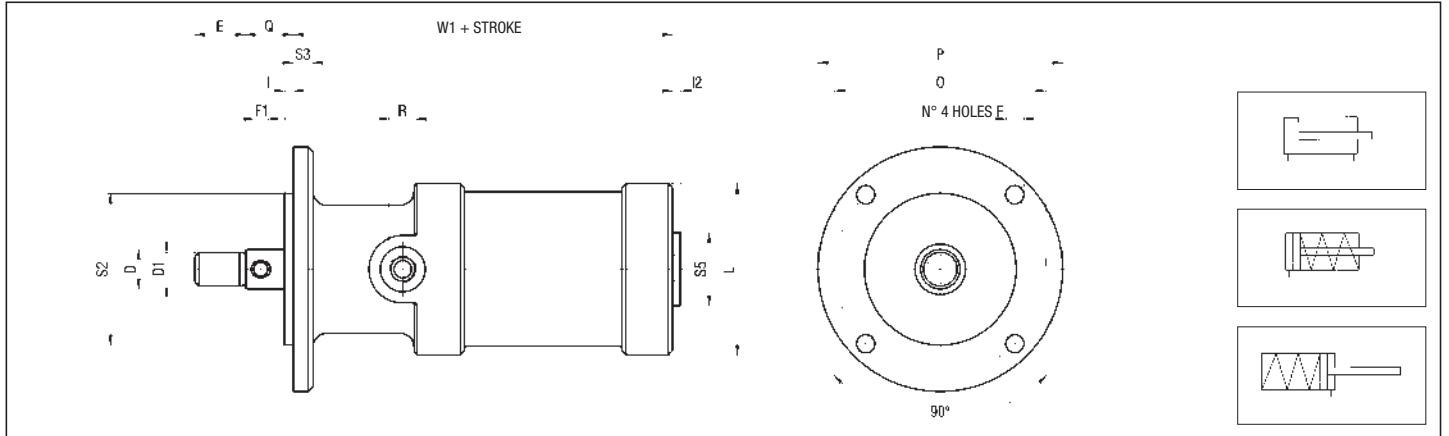

1

THROUGH ROD

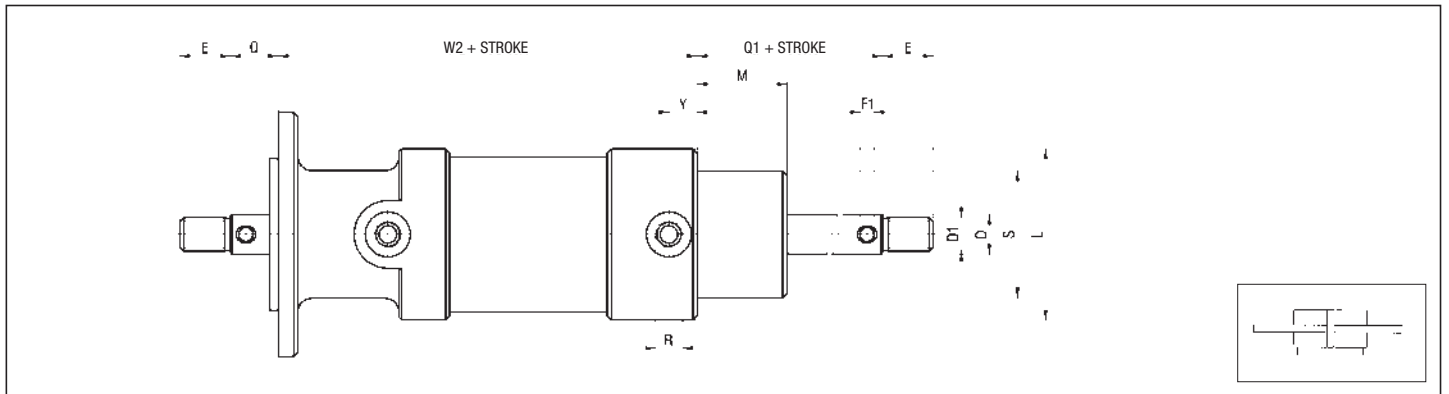

THROUGH ROD, REDUCED END CAP

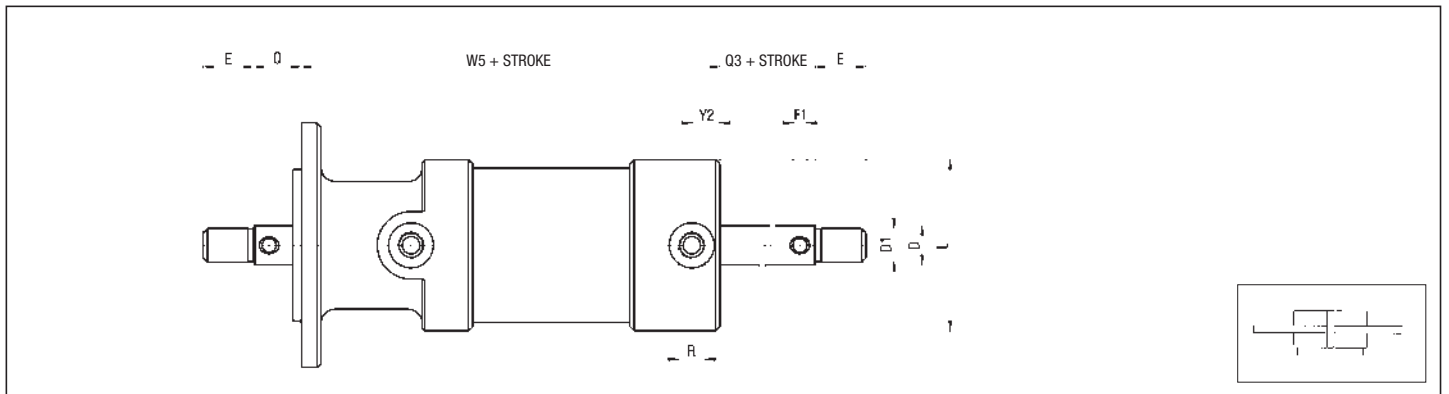

DIMENSIONS AND WEIGHTS BASIC CYLINDER - FAB

Ø	D	D1	E	F	F1	I	I2	L	M	O	P	Q	Q1	Q3	R	S	S2	S3	S5	W1	W2	W5	Y	Y2	WEIGHT (g)	INCREM. (g) every 10 mm
20	8	M6	9	4,2	3	2	3,5	30	16	39	50	10	24	8	G 1/8	24	23	4	14	55	72	75	10	11,5	91	15
27	10	M8	12	4,5	4	2	3,5	35	20	48	58	12	30	10	G 1/8	28	30	6	14	63,5	78,5	80,5	9,5	11,5	178	20
35	12	M10	15	5,5	4	2	3,5	45	24	54	66	14	36	12	G 1/8	32	36	6	18	69,5	83,5	85,5	9,5	10	317	32
40	12	M10	15	6,5	4	3	3	50	32	57	69	15	44	12	G 1/8	36	40	7	24	80	97	98	10	10	427	35
50	14	M12	18	6,5	5	3	3	61	32	75	87	17	46	14	G 1/8	42	54	7	26	85	99	102	10	10	689	44
58	16	M14	21	6,5	5	3	4	70	32	82	100	19	48	16	G 1/4	45	60	8	30	88	104	106	12	14	915	53
70	18	M16	24	8,5	5	4	4	82	35	100	119	22	53	18	G 1/4	50	70	10	30	94	111	117	14	16	1244	64
85	20	M18	27	10,5	6	4	4	98	44,5	120	140	24	64,5	20	G 1/4	60	80	11	40	103	119,5	124	12,5	14	2113	89
100	24	M20	30	10,5	6	4	4	114	50	137	160	28	74	24	G 1/4	70	88	12	40	118	135	136	14	19	3200	110

1

BASIC CYLINDER REAR FLANGE-MOUNTED - FPB

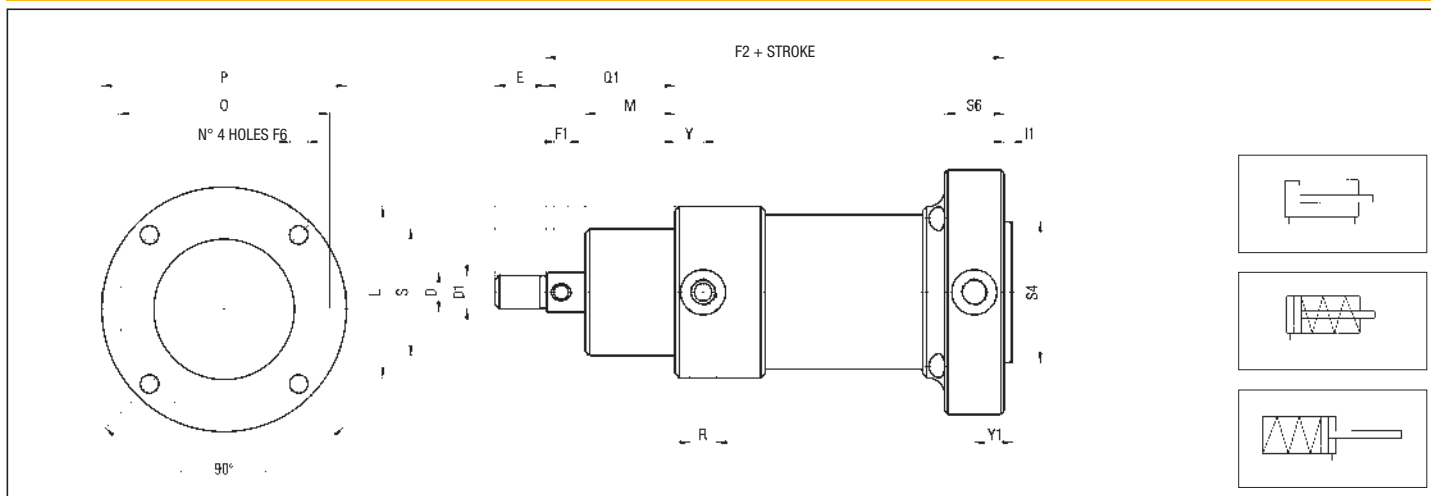

REDUCED END CAP

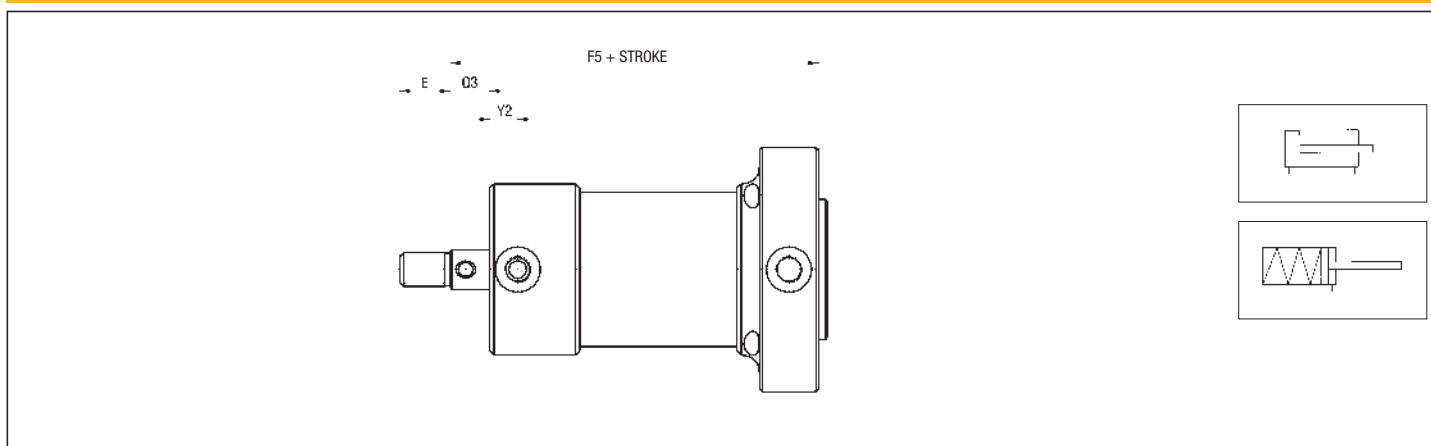

DIMENSIONS AND WEIGHTS BASIC CYLINDER FPB

Ø	D	D1	E	F1	F2	F5	F6	I1	L	M	O	P	Q1	Q3	R	S	S4	S6	Y	Y1	Y2	WEIGHT (g)	INCREM. (g) every 10 mm
20	8	M6	9	3	78	65	4,2	2	30	16	39	50	24	8	G 1/8	24	23	18	10	11	11,5	91	15
27	10	M8	12	4	89	69	4,5	2	35	20	48	58	30	10	G 1/8	28	30	19	9,5	11,5	11,5	178	20
35	12	M10	15	4	97	75	5,5	2	45	24	59	69	36	12	G 1/8	32	38	19	9,5	11,5	10	317	32
40	12	M10	15	4	109	78	5,5	3	50	32	62	74	44	12	G 1/8	36	40	21	10	13,5	10	427	35
50	14	M12	18	5	113	84	6,5	3	61	32	75	87	46	14	G 1/8	42	50	21	10	13,5	10	689	44
58	16	M14	21	5	122	92	8,5	3	70	32	86	100	48	16	G 1/4	45	62	24	12	15	14	915	53
70	18	M16	24	5	131	102	8,5	4	82	35	100	119	53	18	G 1/4	50	72	22	14	15	16	1244	64
85	20	M18	27	6	147	107	10,5	4	98	44,5	120	140	64,5	20	G 1/4	60	80	25	12,5	16,5	14	2113	89
100	24	M20	30	6	164	115	10,5	4	114	50	137	160	74	24	G 1/4	70	88	28	14	18	19	3200	110

DESCRIPTION

Rodless cylinders series "Z" are suitable for applications where long strokes are required, as they have been designed with reduced overall dimensions if compared to the standard cylinders with external rod. The short cylinder (version "K") has a basic length (0-stroke) up to 40% shorter than the "S" standard version. The guided versions (options "F" & "FF") allow the translation of non-guided loads and offer great resistance to transversal forces. Cylinders series "Z" have the magnetic piston type as standard and so they can be supplied with magnetic sensors.



TECHNICAL DATA

Operating pressure	2 ÷ 8 bar
Working temperature	0 ÷ +80 °C (-20 °C with dry air)
Fluid	Filtered, unlubricated or continuous lubricated compressed air
Versions	Standard yoke; Short yoke
Bore	Ø 18, 25, 32, 40, 50, 63
Port size	Ø 18 = M 5 Ø 25 - 32 = G 1/8 Ø 40 - 50 = G 1/4 Ø 63 = G 3/8
Decelerators length	Ø 18 25 32 40 50 63 mm 15 18 24 34 40 49
Maximum strokes (mm)	Ø 18 ÷ 63 = 6000

MATERIALS

End caps	Anodized aluminium alloy
Cylinder barrel	Extruded profile, anodized aluminium alloy
Sealing strip	Polyamide
Cover strip	AISI 304 stainless steel
Head wiper	Acetal resin
Piston	Aluminium alloy with piston seal in acetal resin
Yoke	Anodized aluminium alloy
Decelerators ogives	Brass
Seals	Polyurethane

ORDER KEY

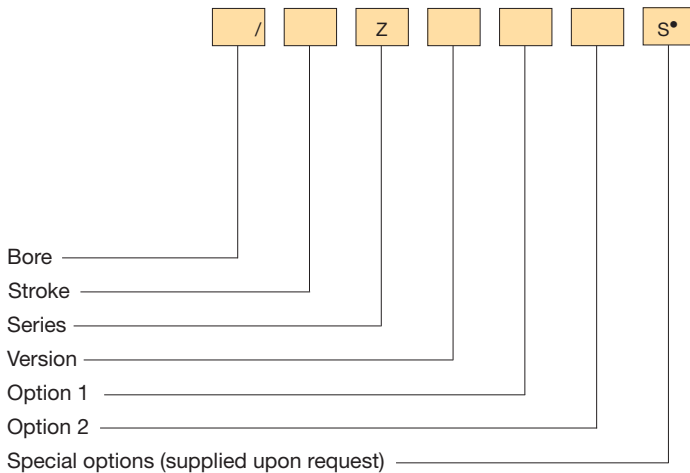

P.S.: *Magnetic sensors* FM 100 - FM 101 (see chapter magnetic sensors from page 1.93)
 • See technical data on page 0.12

VERSION

S Standard yoke **K** Short yoke

OPTION 1

F Single guide **FF** Double guide*

OPTION 2

1 One side ported** **2** Bottom ported**

* Supplied only for "S" version
 ** Supplied from Ø 25 to Ø 63

ORDER EXAMPLES

Rodless cylinder Ø50, 500 mm stroke, with standard yoke and ports 50/500 ZS

Rodless cylinder Ø50, 1000 mm stroke, short yoke, single guide, one side ports 50/1000 ZKF1

SPARE PARTS

Seals kit - Polyurethane	Ø/SG/Z
Sealing strip (min. 500 mm)	Ø/BP/Z/mm
Cover strip (min. 500 mm)	Ø/BM/Z/mm

TECHNICAL INFORMATION

MAXIMUM PERMISSIBLE FORCES

1

Ø	F x in (N) a 6 bar - speed ≤ 0,35 m/s					F z in (N) - speed ≤ 0,35 m/s					F y in (N) - speed ≤ 0,35 m/s				
	ZS	ZK	ZSF	ZSFF	ZKF	ZS	ZK	ZSF	ZSFF	ZKF	ZS	ZK	ZSF	ZSFF	ZKF
18	140	140	140	140	140	300	140	370	550	150	80	40	370	550	150
25	270	270	270	270	270	480	230	800	1200	250	110	55	800	1200	250
32	440	440	440	440	440	650	320	1200	1800	450	165	70	1200	1800	450
40	680	680	680	680	680	800	400	1600	2400	600	225	100	1600	2400	600
50	1060	1060	1060	1060	1060	1060	480	2100	3200	900	325	140	2100	3200	900
63	1680	1680	1680	1680	1680	1680	590	2800	4200	1100	435	180	2800	4200	1100

Ø	Speed = 0,75 m/s					Speed = 1 m/s					Speed = 1,5 m/s				
	ZS	ZK	ZSF	ZSFF	ZKF	ZS	ZK	ZSF	ZSFF	ZKF	ZS	ZK	ZSF	ZSFF	ZKF
18	80	40	100	150	50	40	25	58	80	30	20	10	26	20	12
25	155	90	280	420	100	90	50	160	210	60	40	25	65	80	30
32	280	200	510	750	250	155	110	300	400	135	70	45	140	170	65
40	500	420	1000	1500	480	290	240	550	750	280	125	110	250	300	140
50	790	750	1500	2200	800	420	440	850	1150	480	195	190	380	460	220
63	1500	1500	2500	3700	1500	850	850	1400	1900	950	370	380	610	740	400

N.B.: $\Sigma F = \text{Resultant force} = Ft = \sqrt{F_x^2 + F_z^2 + F_y^2}$

MAXIMUM PERMISSIBLE TORQUE

Ø	M x in (Nm)					M z in (Nm)					M y in (Nm)				
	ZS	ZK	ZSF	ZSFF	ZKF	ZS	ZK	ZSF	ZSFF	ZKF	ZS	ZK	ZSF	ZSFF	ZKF
18	1	0,4	3,5	5,2	1,8	3	1,7	6	9	1,8	3	1,7	6	9	1,8
25	2	0,7	10	15	4	13	2,7	20	30	4	13	2,7	20	30	4
32	3,5	1	25	37	10	25	5	45	67	10	25	5	45	67	10
40	5,5	2	40	60	16	40	8,5	75	110	16	40	8,5	75	110	16
50	10	3,5	80	120	30	65	13	150	220	30	65	13	150	220	30
63	16	5	110	170	45	100	18	250	370	45	100	18	250	370	45

MAXIMUM PERMISSIBLE FORCE "Fz" (as a function of the distance "L" between supports and of the deflection request)

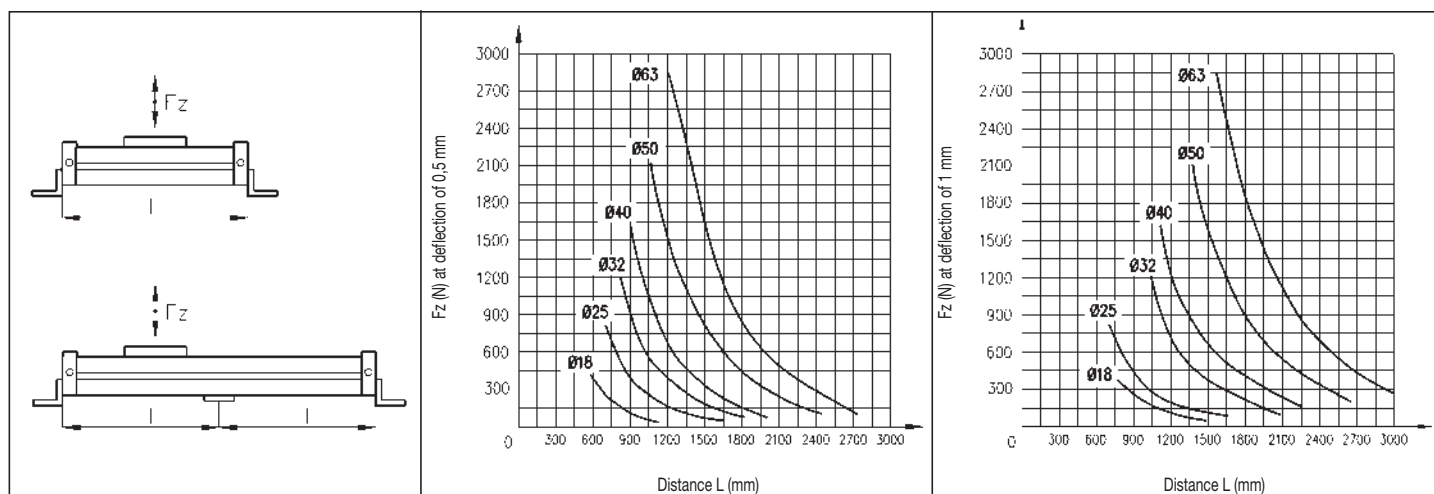

ZS BASIC CYLINDER WITH STANDARD YOKE

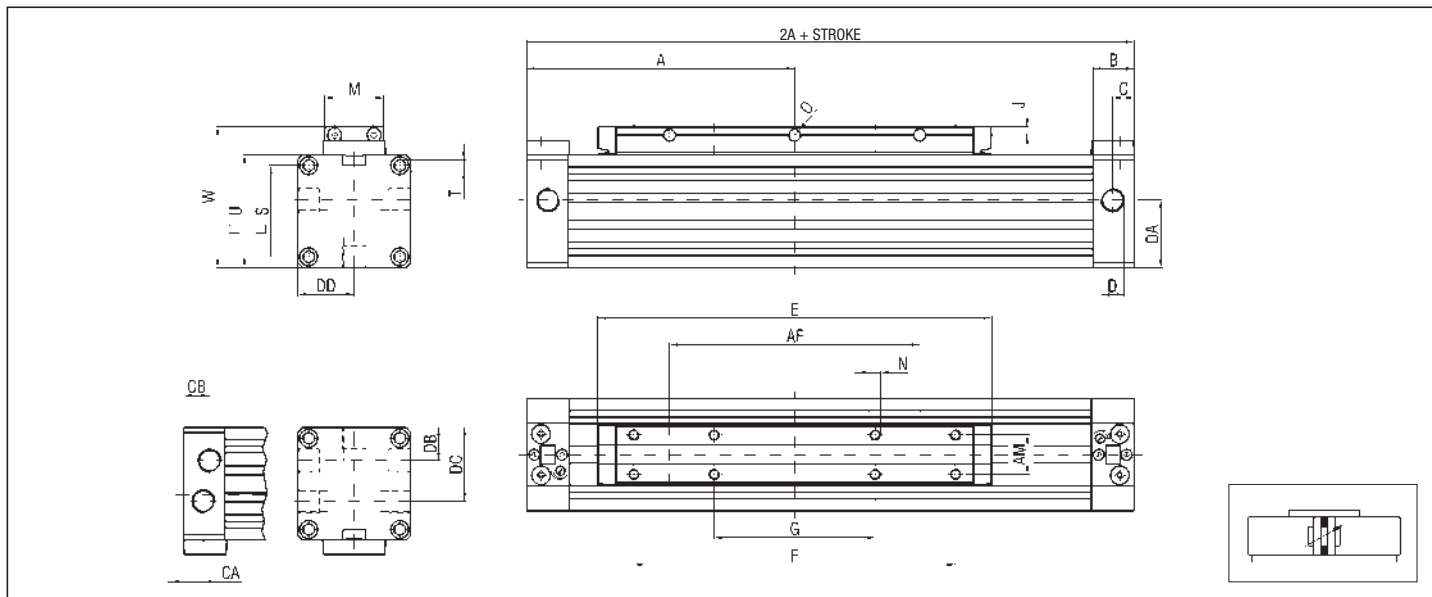

DIMENSIONS AND WEIGHTS ZS BASIC CYLINDER

Ø	A	AF	AM	B	C	CA	CB	D	DA	DB	DC	DD	E	F	G	J	M	N	O	S	T	U	W	WEIGHT (g)	INCR. (g) x10 mm
18	80	50	10	16,5	6,5	-	-	M5	17,5	-	-	15	103	75	-	3	15,5	M3x6	3,5	23,5	M3x7	30	39	300	15
25	100	70	13	20	8,5	7	13	G1/8	25,5	14	28	21	131	100	50	3,5	20	M4x7	4,5	33	M4x9	42	53	600	26
32	120	100	16	20	8,5	7	13	G1/8	32	17,5	34,5	26	171	140	70	4,5	25	M5x9	5,5	41	M5x10	52	65	1100	36
40	150	140	22	24	11	9,5	14,5	G1/4	37,5	20	42	31,5	220	180	90	5	33	M6x10	7	51	M6x12	63	79	1800	48
50	180	180	29	24	11	9,5	14,5	G1/4	47,5	26	52	39	280	220	110	6,5	42	M8x12,5	7	63	M8x12	78	96	3200	74
63	215	230	40	30	14,5	11	18,5	G3/8	59,5	30	62	46,5	333	280	140	8	54	M8x15	9	78	M8x12	93	113,5	5600	100

ZK BASIC CYLINDER WITH SHORT YOKE

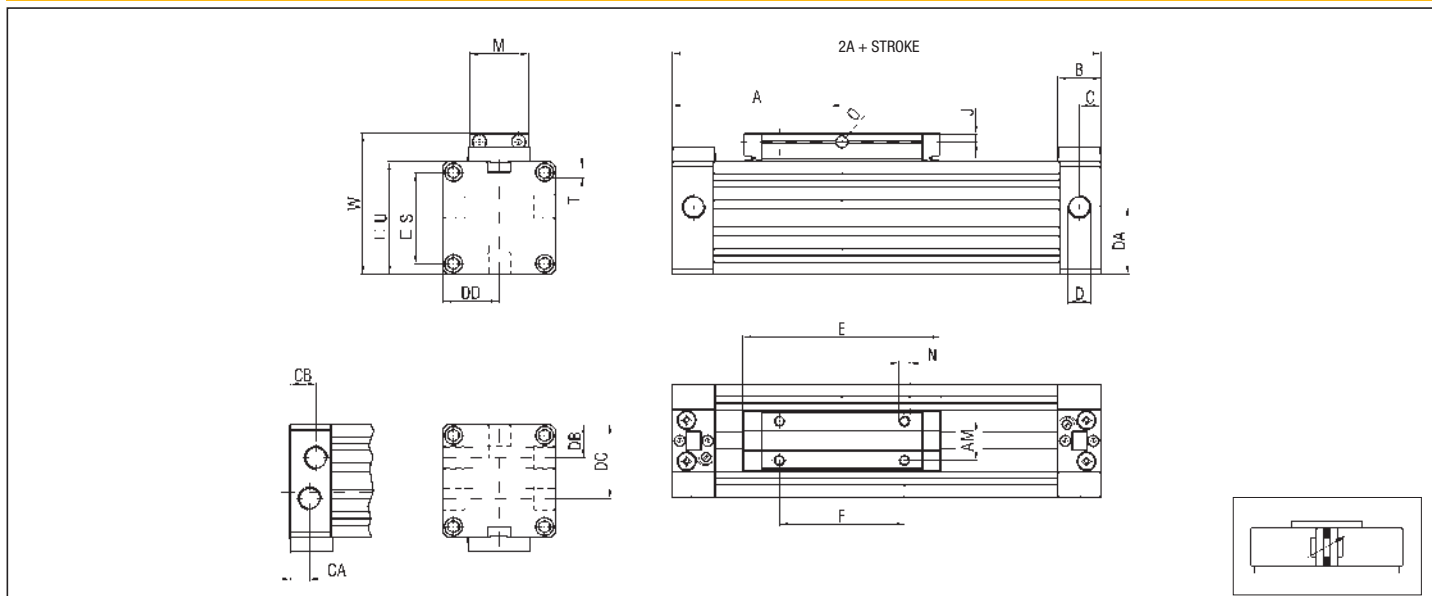

DIMENSIONS AND WEIGHTS ZK BASIC CYLINDER

Ø	A	AM	B	C	CA	CB	D	DA	DB	DC	DD	E	F	J	M	N	O	S	T	U	W	WEIGHT (g)	INCR. (g) x10 mm
18	57,5	10	16,5	6,5	-	-	M5	17,5	-	-	15	58	30	3	15,5	M3x6	3,5	23,5	M3x7	30	39	200	15
25	67,5	13	20	8,5	7	13	G1/8	25,5	14	28	21	66	35	3,5	20	M4x7	4,5	33	M4x9	42	53	400	26
32	77,5	16	20	8,5	7	13	G1/8	32	17,5	34,5	26	86	55	4,5	25	M5x9	5,5	41	M5x10	52	65	700	36
40	95	22	24	11	9,5	14,5	G1/4	37,5	20	42	31,5	110	70	5	33	M6x10	7	51	M6x12	63	79	1200	48
50	105	29	24	11	9,5	14,5	G1/4	47,5	26	52	39	130	70	6,5	42	M8x12,5	7	63	M8x12	78	96	2000	74
63	125	40	30	14,5	11	18,5	G3/8	59,5	30	62	46,5	153	100	8	54	M8x15	9	78	M8x12	93	113,5	3200	100

1

ZSF BASIC CYLINDER WITH STANDARD YOKE AND SINGLE GUIDE

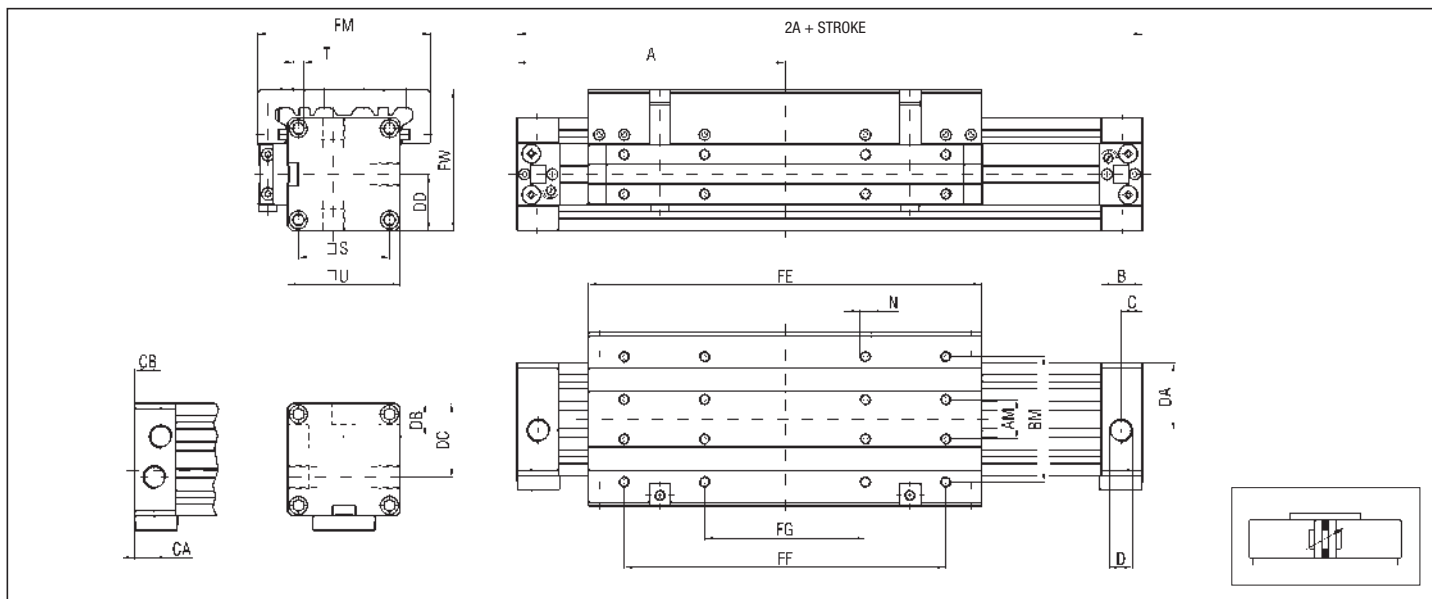

DIMENSIONS AND WEIGHTS ZSF BASIC CYLINDER

Ø	A	AM	B	BM	C	CA	CB	D	DA	DB	DC	DD	FE	FF	FG	FM	FW	N	S	T	U	WEIGHT (g)	INCR. (g) x10 mm
18	80	10	16,5	35	6,5	-	-	M5	17,5	-	-	15	103	75	-	50	39	M4x7,5	23,5	M3x7	30	400	15
25	100	13	20	45	8,5	7	13	G1/8	25,5	14	28	21	131	100	50	66	53	M4x8	33	M4x9	42	900	26
32	120	16	20	55	8,5	7	13	G1/8	32	17,5	34,5	26	171	140	70	80	65	M5x10	41	M5x10	52	1500	36
40	150	22	24	70	11	9,5	14,5	G1/4	37,5	20	42	31,5	220	180	90	97	79	M6x12	51	M6x12	63	2800	48
50	180	29	24	85	11	9,5	14,5	G1/4	47,5	26	52	39	280	220	110	116	96	M8x16	63	M8x12	78	4900	74
63	215	40	30	105	14,5	11	18,5	G3/8	59,5	30	62	46,5	333	280	140	136	113,5	M8x16	78	M8x12	93	8000	100

ZSFF BASIC CYLINDER WITH STANDARD YOKE AND DOUBLE GUIDE

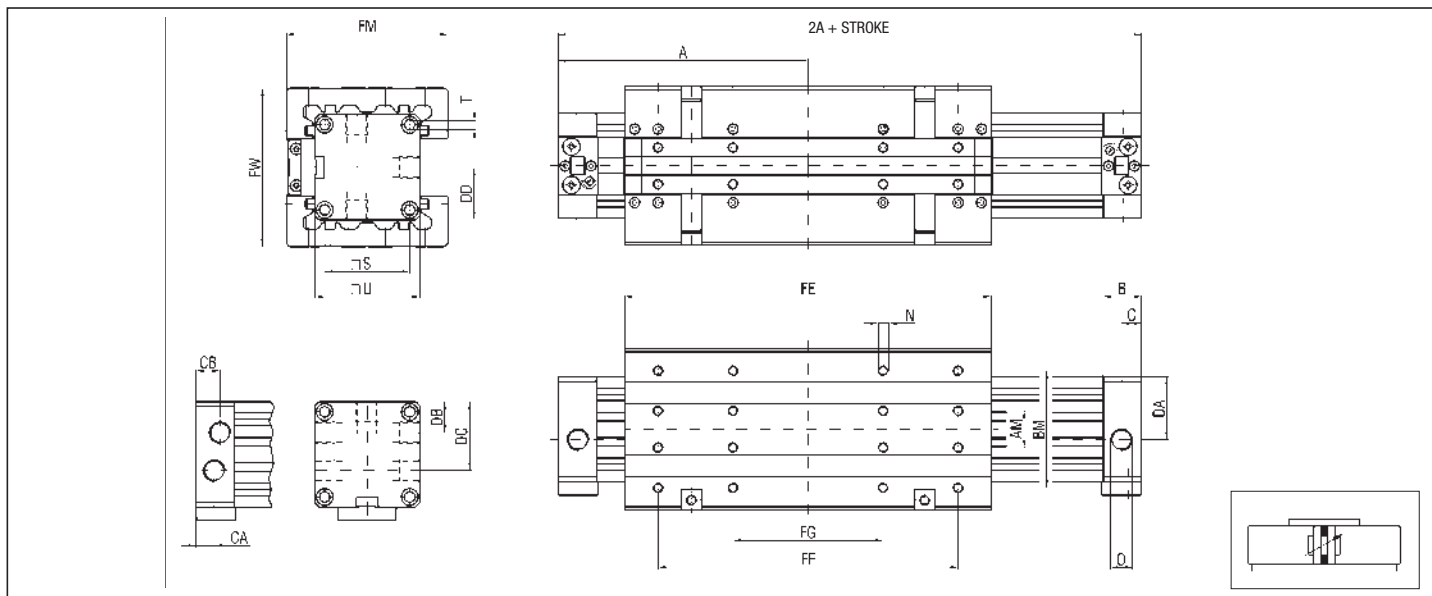

DIMENSIONS AND WEIGHTS ZSFF BASIC CYLINDER

Ø	A	AM	B	BM	C	CA	CB	D	DA	DB	DC	DD	FE	FF	FG	FM	FW	N	S	T	U	WEIGHT (g)	INCR. (g) x10 mm
18	80	10	16,5	35	6,5	-	-	M5	17,5	-	-	15	103	75	-	50	50	M4x7,5	23,5	M3x7	30	500	15
25	100	13	20	45	8,5	7	13	G1/8	25,5	14	28	21	131	100	50	66	64	M4x8	33	M4x9	42	1200	26
32	120	16	20	55	8,5	7	13	G1/8	32	17,5	34,5	26	171	140	70	80	78	M5x10	41	M5x10	52	1900	36
40	150	22	24	70	11	9,5	14,5	G1/4	37,5	20	42	31,5	220	180	90	97	95	M6x12	51	M6x12	63	3800	48
50	180	29	24	85	11	9,5	14,5	G1/4	47,5	26	52	39	280	220	110	116	114	M8x16	63	M8x12	78	6600	74
63	215	40	30	105	14,5	11	18,5	G3/8	59,5	30	62	46,5	333	280	140	136	134	M8x16	78	M8x12	93	10400	100

ZKF BASIC CYLINDER WITH SHORT YOKE AND SINGLE GUIDE

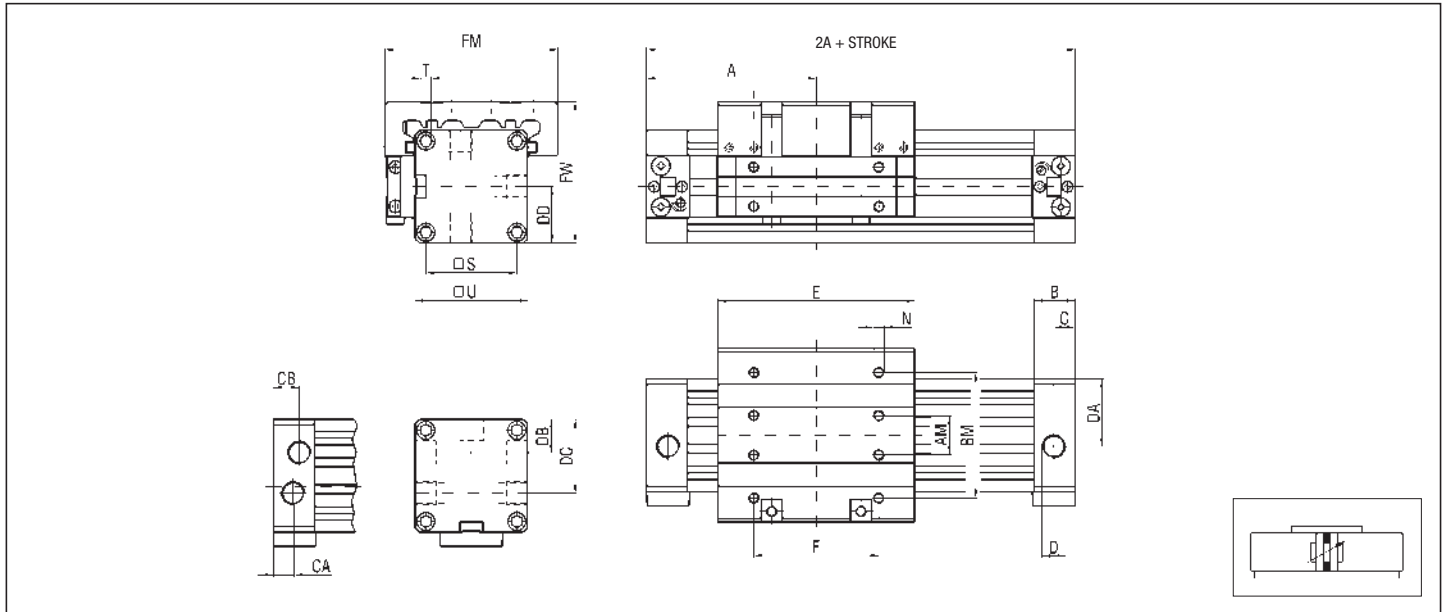

DIMENSIONS AND WEIGHTS ZKF BASIC CYLINDER

Ø	A	AM	B	BM	C	CA	CB	D	DA	DB	DC	DD	E	F	FM	FW	N	S	T	U	WEIGHT (g)	INCR. (g) x10 mm
18	57,5	10	16,5	35	6,5	-	-	M5	17,5	-	-	15	58	30	50	39	M4x7,5	23,5	M3x7	30	300	15
25	67,5	13	20	45	8,5	7	13	G1/8	25,5	14	28	21	66	35	66	53	M4x8	33	M4x9	42	600	26
32	77,5	16	20	55	8,5	7	13	G1/8	32	17,5	34,5	26	86	55	80	65	M5x10	41	M5x10	52	1150	36
40	95	22	24	70	11	9,5	14,5	G1/4	37,5	20	42	31,5	110	70	97	79	M6x12	51	M6x12	63	2000	48
50	105	29	24	85	11	9,5	14,5	G1/4	47,5	26	52	39	130	70	116	96	M8x16	63	M8x12	78	3200	74
63	125	40	30	105	14,5	11	18,5	G3/8	59,5	30	62	46,5	153	100	136	113,5	M8x16	78	M8x12	93	6400	100

FEET (pair) - ALUMINIUM - ZPB Ø

Ø	AA	AB	AC	AD	AE	AH	WEIGHT (g)
18	15	2	10	20	6	2	35
25	18	2	12,5	30	6	2	40
32	20	2,5	13,5	40	7	3	75
40	25	2,5	17,5	50	9	3	115
50	28	3	20	60	9	3	225
63	30	3	21	75	11	4,5	280

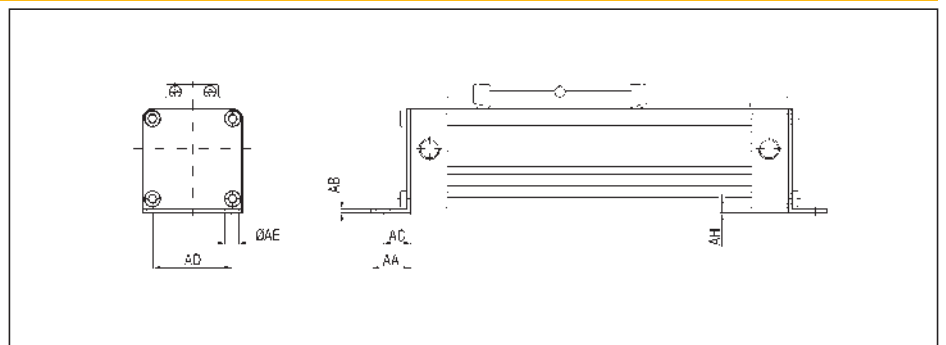

1

MIDDLE SUPPORTS (pair) - ALUMINIUM - ZTI Ø

Ø	AE	AH	BA	BB	BC	BD	BE	BF	WEIGHT (g)
18	6	2	56	46	36,5	23	2,5	8,25	10
25	6	2	70	60	50	28	3,5	11	15
32	7	3	85	73	61,5	33	4	13,8	30
40	9	3	105	90	75	38	4,5	16	45
50	9	3	122	106	91	43	5	19	60
63	11	4,5	144	125	107	48	6	22	80

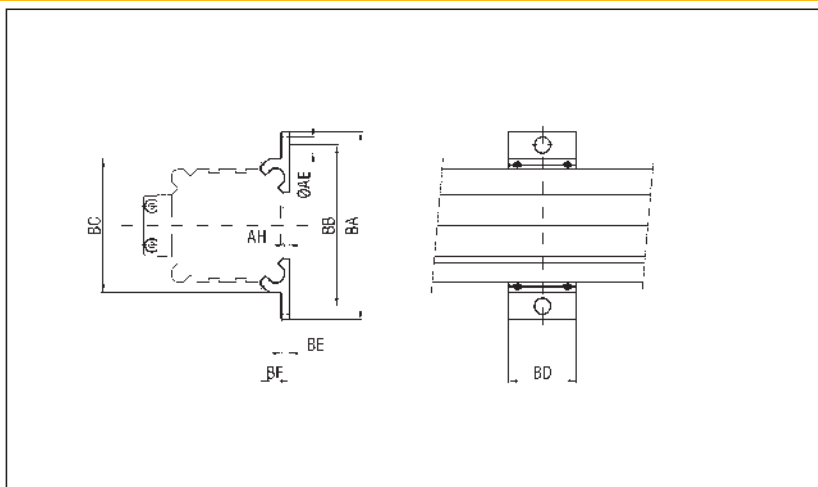

NARROW SWINGING BRIDGE - ALUMINIUM - ZCS Ø

Ø	CA	CB	CC	CD	CE	CF	CG	CK
18	50	25,5	30	9	M5	54	2,5	M4
25	60	30	40	14	M5	70	3	M4
32	70	37	50	16	M6	86	3,5	M5
40	80	47	60	22	M8	107	4,5	M6
50	90	56	70	30	M8	123	4,5	M6
63	100	73	80	40	M10	145,5	5	M8

Ø	CJ	CH	WEIGHT (g)
18	4	4	45
25	4	4	60
32	6	6	115
40	8	8	220
50	8	8	275
63	8	8	470

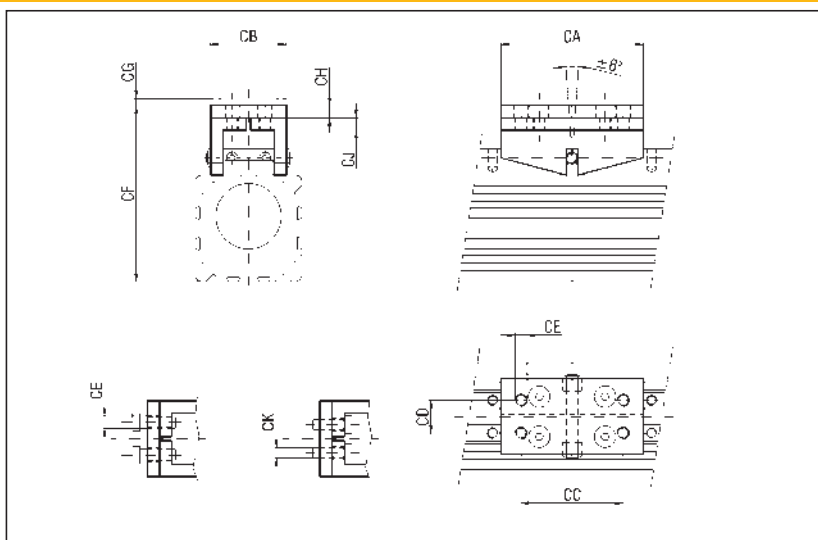

LARGE SWINGING BRIDGE - ALUMINIUM - ZCL Ø

Ø	CA	CB	CC	CD	CE	CF	CG	CK
18	50	41,5	30	34	M5	54	2,5	M4
25	60	50	40	38	M5	70	3	M4
32	70	60	50	48	M6	86	3,5	M5
40	80	80	60	60	M8	107	4,5	M6
50	90	95	70	70	M8	123	4,5	M6
63	100	120	80	80	M10	145,5	5	M8

Ø	CJ	CH	WEIGHT (g)
18	4	4	50
25	4	4	80
32	6	6	145
40	8	8	275
50	8	8	350
63	8	8	575

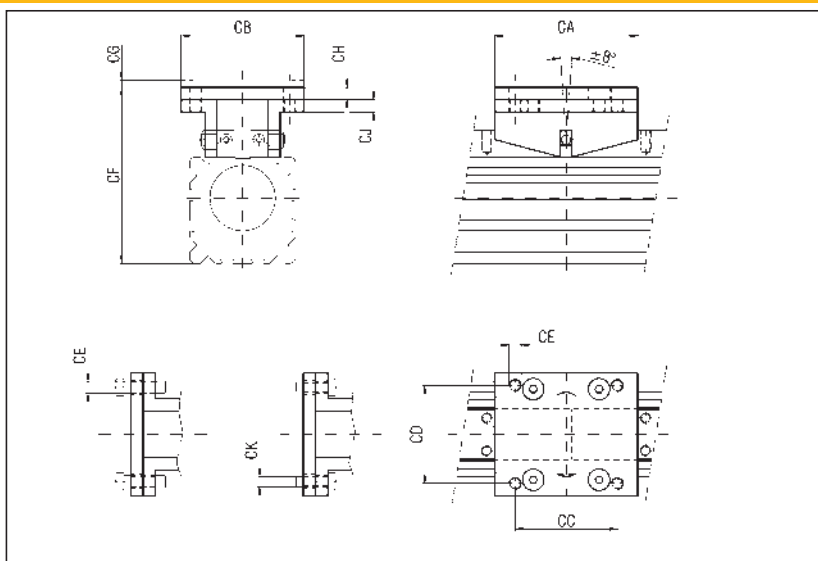

DESCRIPTION

Hydraulic regulators series “HS” assure a constant speed of pneumatic cylinders during their working cycle. In fact in the control of tools, that during their movements meet different resistances (i.e. violent impacts and vibrations) with the consequent variation of speed due to the use of only pneumatic control, you could obtain coarse finishes of the tooling till reach the breaking of the same tool. The hydraulic speed regulators exploit the oil incompressibility that, passing from a chamber to another one through an externally adjustable flow regulator, manages to uniform the speed and, with the use of control valves, avoids dead times warranting perfectly repeatable stops independently from the applied load. The adjustment can be made during the piston rod thrust phase, retract phase or both. The stop valve (STOP), mounted in-line on the circuit, and the acceleration valves (SKIP), mounted in-parallel, can be inserted in both the phases. These are poppet valves, two port, pneumatically actuated and therefore they have to be operated to make the STOP valve insert and to cut out the SKIP one.



1

TECHNICAL DATA

Working temperature	0 ÷ +70 °C (-10 °C with dry air)
Fluid	Hydraulic oil (WAIRSOL HS: contact our commercial office for details)
Versions	In-line tank, piston rod thrust adjustment; In-parallel tank, piston rod thrust adjustment; In-parallel tank, piston rod retract adjustment; In-parallel tank, double adjustment
Bore	Ø 40
Standard strokes (mm)	50, 100, 150, 200, 250, 300, 350, 400, 450, 500
Maximum stroke (mm)	1000
Maximum adjustable load	6000 N
Minimum/Maximum permissible speed (mm/min)	Without valves: 60 ÷ 10.000 With valves: 0 ÷ 6.000

MATERIALS

End caps	Anodized aluminium alloy
Cylinder barrel	Drawn steel
Piston rod	C45 chromium-plated steel
Piston	Anodized aluminium alloy
Piston seal	NBR rubber
Piston rod seal	Polyurethane
Tie rods	Steel
Adjusting groups	Nickel-plated brass
Oil lever stick	Anodized aluminium alloy

ORDER KEY

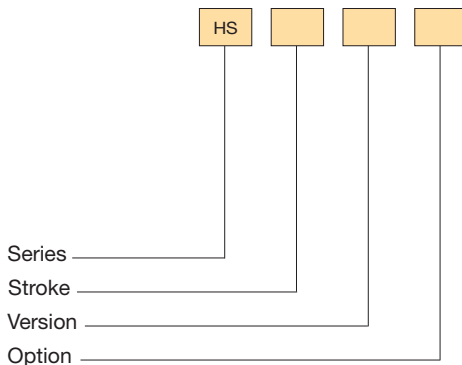

VERSIONS

- LU** In-line tank, piston rod thrust adjustment
- PU** In-parallel tank, piston rod thrust adjustment
- PR** In-parallel tank, piston rod retract adjustment
- PD** In-parallel tank, double adjustment

OPTIONS

- 1** Standard adjustment
- 2** STOP valve adjustment
- 3** SKIP valve adjustment
- 4** SKIP and STOP valves adjustment

ORDER EXAMPLES

Hydraulic regulator HS, 100 mm stroke, in-parallel tank, stop valve thrust adjustment HS100 PU2

Hydraulic regulator HS, 150 mm stroke, in-parallel tank, skip valve double adjustment + cylinder series “CPUI” Ø63, 150 mm stroke, magnetic piston type + fixing plate + connection bridle + nipple + threaded bar, ASSEMBLED:

HS150 PD3, 63/150 CPUI/M,
 HS/PT 63, HS/BR 50/63,
 HS/NP 50/63, HS/BF Ø
 M/HS

ASSEMBLY

“HS”+ cylinders series “X” or “CPUI”	M/HS
--------------------------------------	------

1

IN-LINE TANK-THRUST ADJUSTMENT - HS..LU1

WEIGHT: 2200 g (0 mm-STROKE) + 61 g EVERY 10 mm OF STROKE

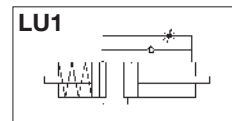
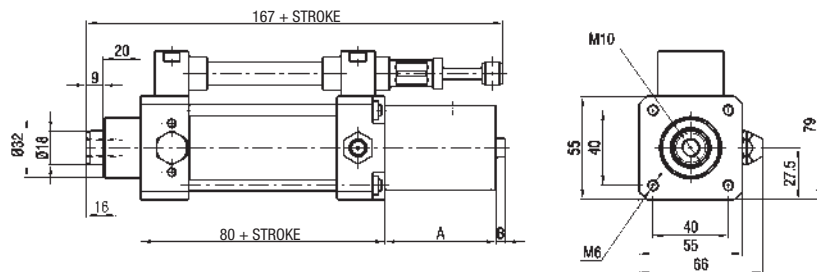

DIMENSIONS WITH IN-LINE TANK-THRUST ADJUSTMENT

STROKES (mm)	A	B (max)
≤ 75	75	25
76 ÷ 150	90	39
151 ÷ 250	142	65
251 ÷ 350	171	87
351 ÷ 500	222	125

IN-LINE TANK-THRUST ADJUSTMENT - HS..LU2 - HS..LU3

WEIGHT LU2: 2700 g (50 mm-STROKE) + 61 g EVERY 10 mm OF STROKE (MIN. STROKE 50 mm)

WEIGHT LU3: 2300 g (0 mm-STROKE) + 61 g EVERY 10 mm OF STROKE (MIN. STROKE 50 mm)

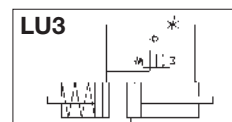
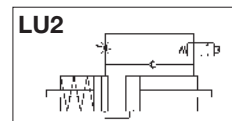
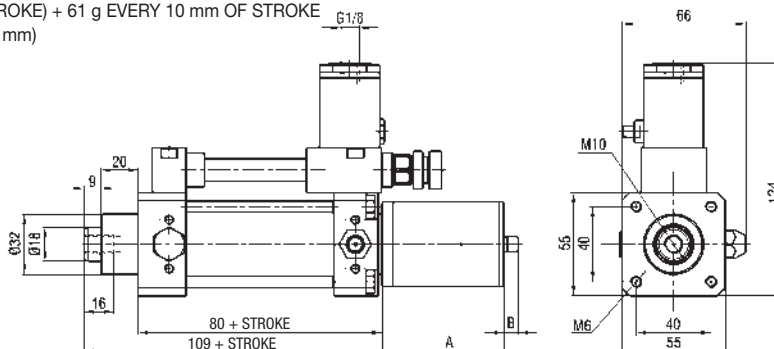

IN-LINE TANK-THRUST ADJUSTMENT - HS..LU4

WEIGHT: 2800 g (50 mm-STROKE) + 61 g EVERY 10 mm OF STROKE (MIN. STROKE 50 mm)

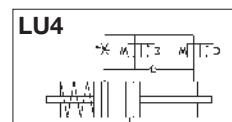
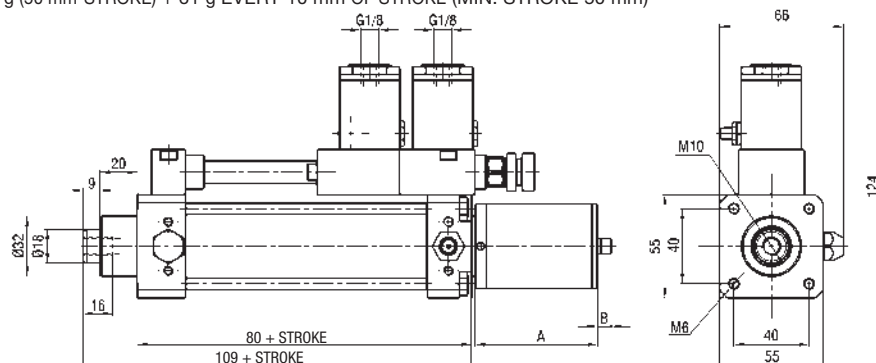

DIMENSIONS WITH IN-LINE TANK-THRUST ADJUSTMENT

STROKES (mm)	A	B (max)
≤ 75	60	25
76 ÷ 150	75	39
151 ÷ 250	127	65
251 ÷ 350	156	87
351 ÷ 500	205	125

IN-PARALLEL TANK-THRUST ADJUSTMENT - HS..PU1

WEIGHT: 2200 g (0 mm-STROKE) + 61 g EVERY 10 mm OF STROKE

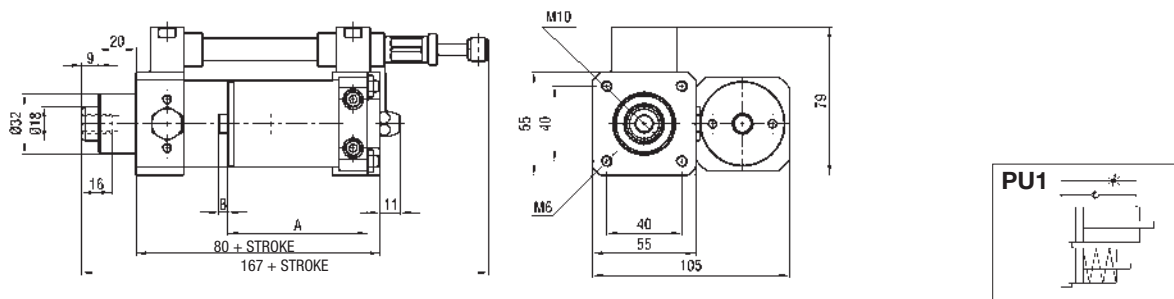

IN-PARALLEL TANK-THRUST ADJUSTMENT - HS..PU2 - HS..PU3

WEIGHT PU2: 2700 g (50 mm-STROKE) + 61 g EVERY 10 mm OF STROKE (MIN. STROKE 50 mm)
 WEIGHT PU3: 2300 g (0 mm-STROKE) + 61 g EVERY 10 mm OF STROKE (MIN. STROKE 50 mm)

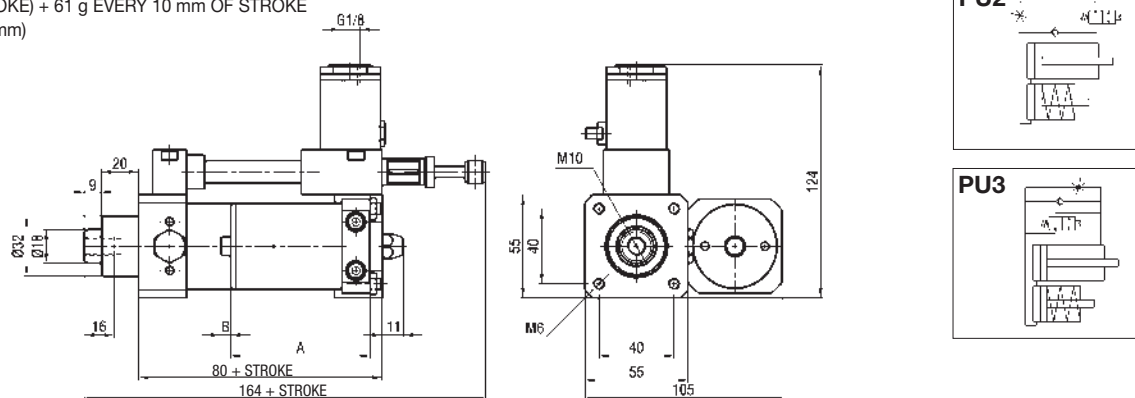

IN-PARALLEL TANK-THRUST ADJUSTMENT - HS..PU4

WEIGHT: 2800 g (50 mm-STROKE) + 61 g EVERY 10 mm OF STROKE (MIN. STROKE 50 mm)

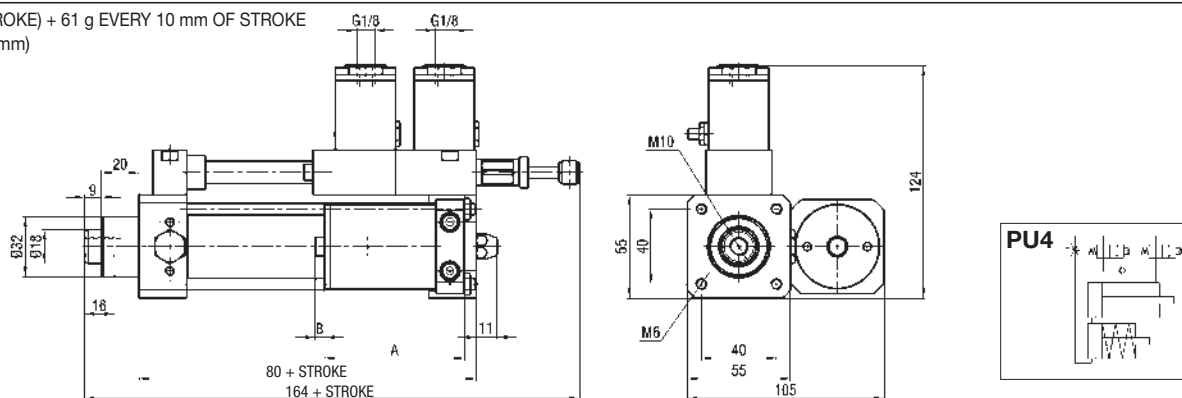

DIMENSIONS WITH IN-PARALLEL TANK-THRUST ADJUSTMENT

STROKES (mm)	A	B (max)
≤ 75	75	25
76 ÷ 150	90	39
151 ÷ 250	142	65
251 ÷ 350	171	87
351 ÷ 500	222	125

1

IN-PARALLEL TANK-RETRACT ADJUSTMENT - HS..PR1

WEIGHT: 2200 g (0 mm-STROKE) + 61 g EVERY 10 mm OF STROKE

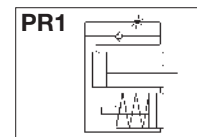
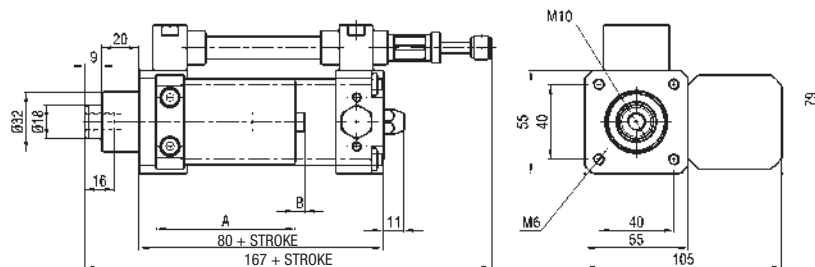

IN-PARALLEL TANK-RETRACT ADJUSTMENT - HS..PR2 - HS..PR3

WEIGHT PR2: 2700 g (50 mm-STROKE) + 61 g EVERY 10 mm OF STROKE (MIN. STROKE 50 mm)
WEIGHT PR3: 2300 g (0 mm-STROKE) + 61 g EVERY 10 mm OF STROKE (MIN. STROKE 50 mm)

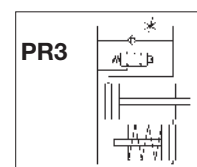
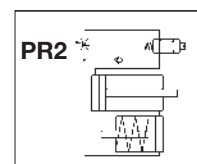
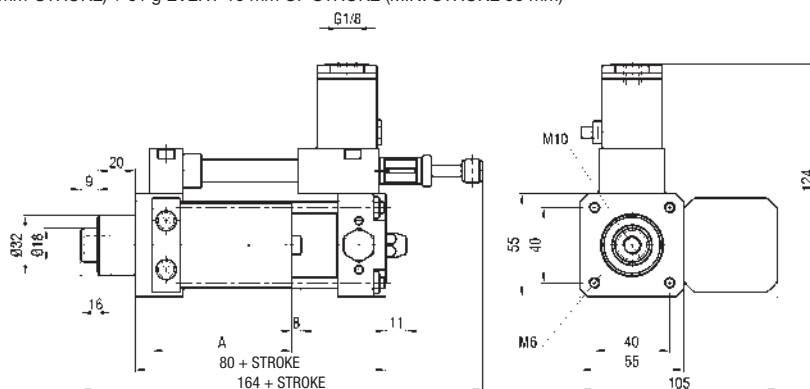

IN-PARALLEL TANK-RETRACT ADJUSTMENT - HS..PR4

WEIGHT: 2800 g (50 mm-STROKE) + 61 g EVERY 10 mm OF STROKE (MIN. STROKE 50 mm)

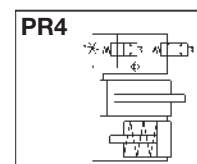
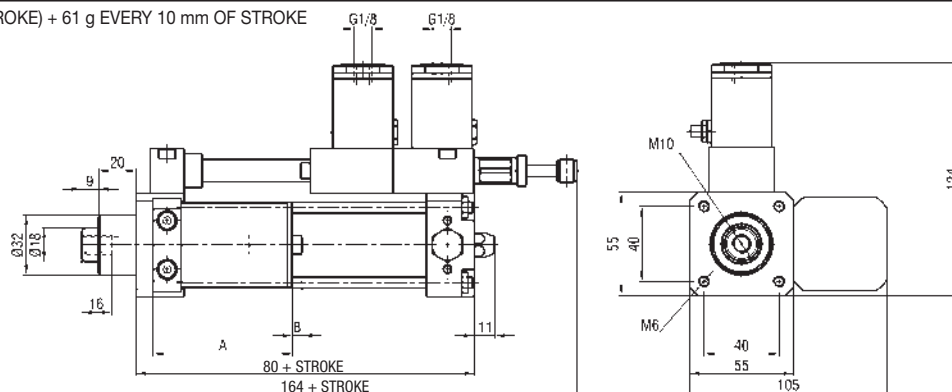

DIMENSIONS WITH IN-PARALLEL TANK-RETRACT ADJUSTMENT

STROKES (mm)	A	B (max)
≤ 75	75	25
76 ÷ 150	90	39
151 ÷ 250	142	65
251 ÷ 350	171	87
351 ÷ 500	222	125

IN-PARALLEL TANK-DOUBLE ADJUSTMENT HS..PD1

WEIGHT: 2900 g (50 mm-STROKE) + 61 g EVERY 10 mm OF STROKE
(MIN. STROKE 50 mm)

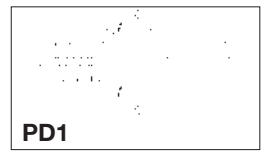
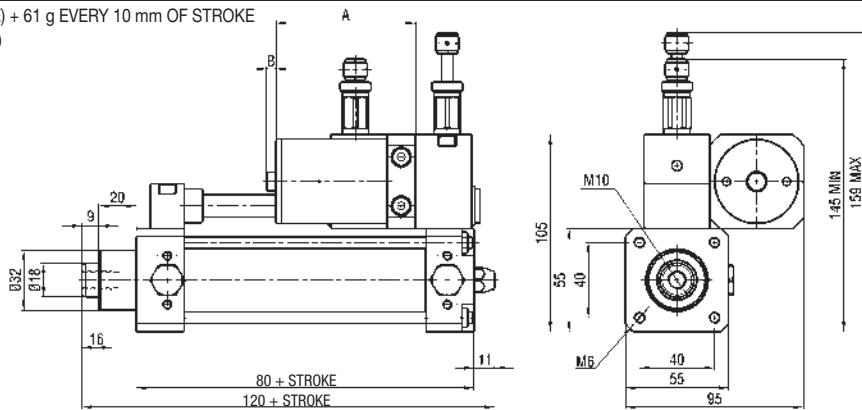

IN-PARALLEL TANK-DOUBLE ADJUSTMENT HS..PD2 - HS..PD3

WEIGHT PD2: 4100 g (150 mm-STROKE)
+ 61 g EVERY 10 mm OF STROKE
(MIN. STROKE 150 mm)
WEIGHT PD3: 3100 g (50 mm-STROKE)
+ 61 g EVERY 10 mm OF STROKE
(MIN. STROKE 50 mm)

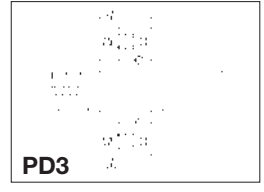
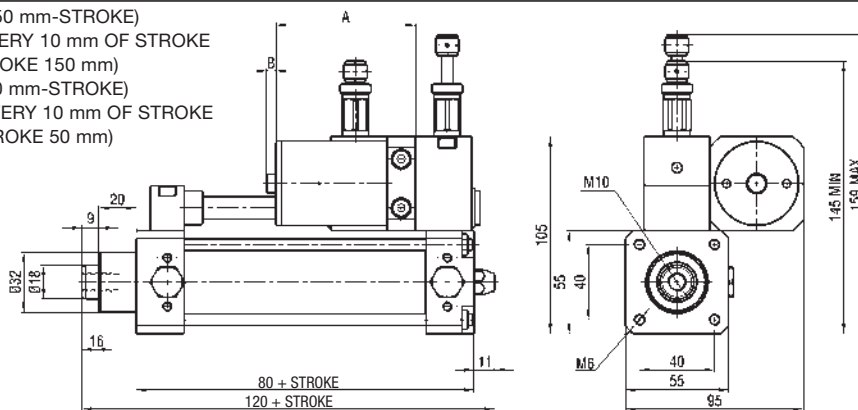

DIMENSIONS WITH IN-PARALLEL TANK-DOUBLE ADJUSTMENT

STROKES (mm)	A	B (max)
50 ÷ 75	75	25
76 ÷ 150	90	39
151 ÷ 250	142	65

STROKES (mm)	A	B (max)
251 ÷ 350	171	87
351 ÷ 500	222	125

IN-PARALLEL TANK-DOUBLE ADJUSTMENT HS..PD4

WEIGHT: 4300 g (150 mm-STROKE)
+ 61 g EVERY 10 mm OF STROKE
(MIN. STROKE 150 mm)

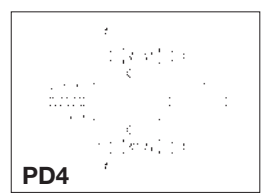
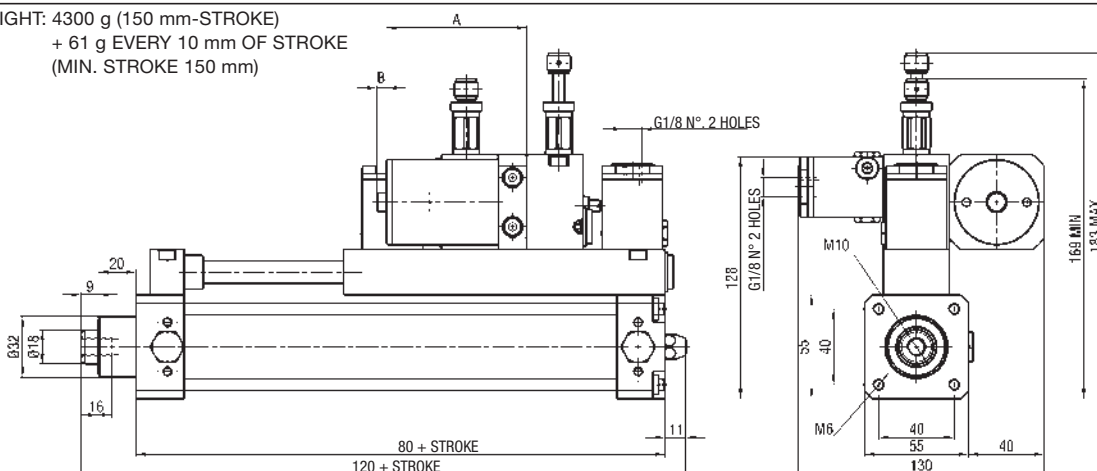

DIMENSIONS WITH IN-PARALLEL TANK-DOUBLE ADJUSTMENT

STROKES (mm)	A	B (max)
150 ÷ 250	142	65
251 ÷ 350	171	87
351 ÷ 500	222	125

1

FIXING PLATE HYDRAULIC REGULATOR/CYLINDERS SERIES "X" and "CPUI" - HS/PT Ø

Ø	B	DA	DB	DC	HA	LD	LF
40	35	32	6,5	6,5	55	111	56,5
50	40	32	6,5	8,5	65	122	62
63	45	32	6,5	8,5	75	132	67
80	45	32	6,5	10,5	95	152	77
100	55	32	6,5	10,5	115	171	86,5

Ø	LG	LH	LI	TG	WEIGHT (g)
40	27	40	10	38	315
50	32,5	40	10	46,5	430
63	37,5	40	12	56,5	666
80	47,5	40	12	72	1080
100	57	40	15	89	1879

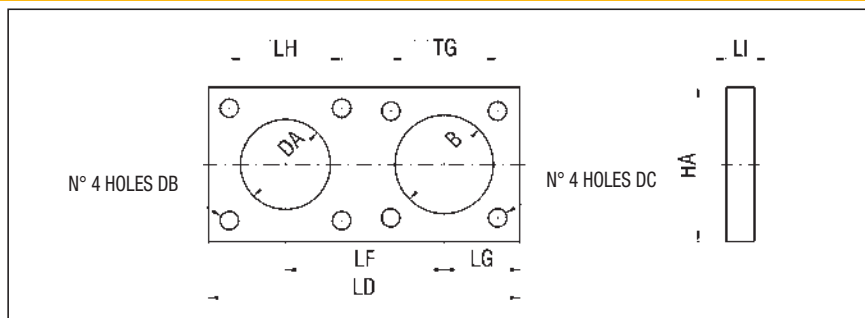

CONNECTION BRIDLE HYDRAULIC REGULATOR/CYLINDERS SERIES "X" and "CPUI" PISTON RODS - HS/BR Ø

Ø	HB	HC	HD	KK	LJ	LK	LL
40	80	25	25	M12x1,25	40	12	20
50 - 63	90	-	-	M16x1,5	40	12	15
80-100	117	-	-	M20x1,5	50	12	20

Ø	LN	LM	TA	TB	WEIGHT (g)
40	8	5	12	56	351
50 - 63	-	-	11,5	62	369
80-100	-	-	18	77	818

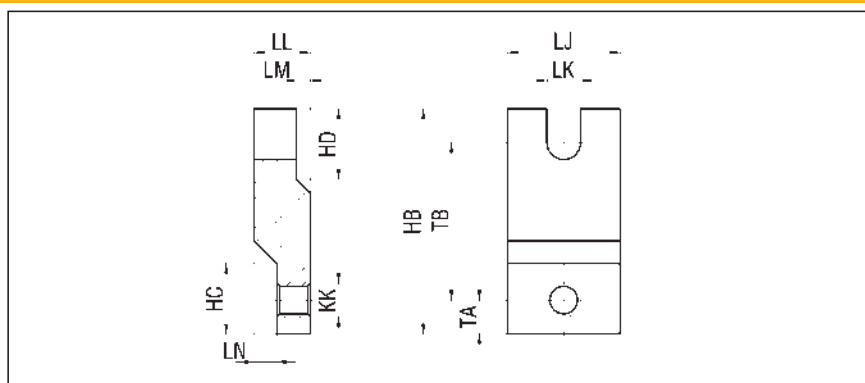

CYLINDERS SERIES "X" and "CPUI" RESTORATION THREAD NIPPLE- HS/NP Ø

Ø	AM	CH	KK	LO	PA	WEIGHT (g)
40	24	19	M12x1,25	47	14	59
50 - 63	32	24	M16x1,5	65	19	131
80-100	40	30	M20x1,5	78	24	245

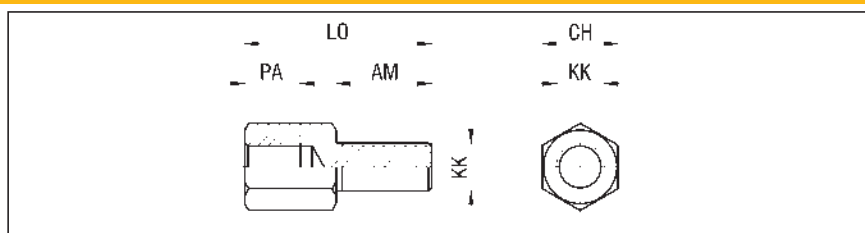

THREADED BAR - HS/BF Ø

Ø	LP	WEIGHT (g)
40	6	166
50 ÷ 100	8	178

P.S.: THREADED BAR IS SUPPLIED WITH 5 NUTS AND 2 WASHERS

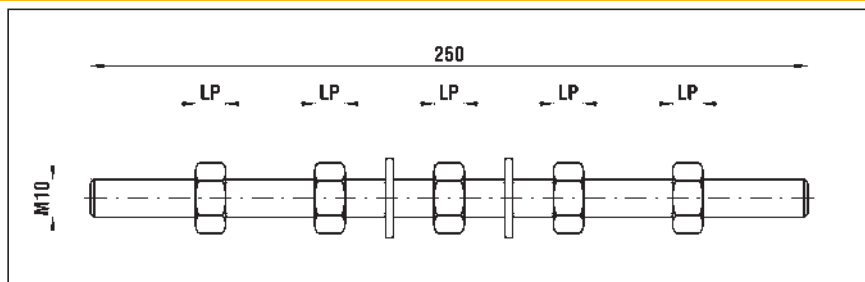

FIXING PLATE HYDRAULIC REGULATOR/CYLINDERS SERIES "X" and "CPUI"

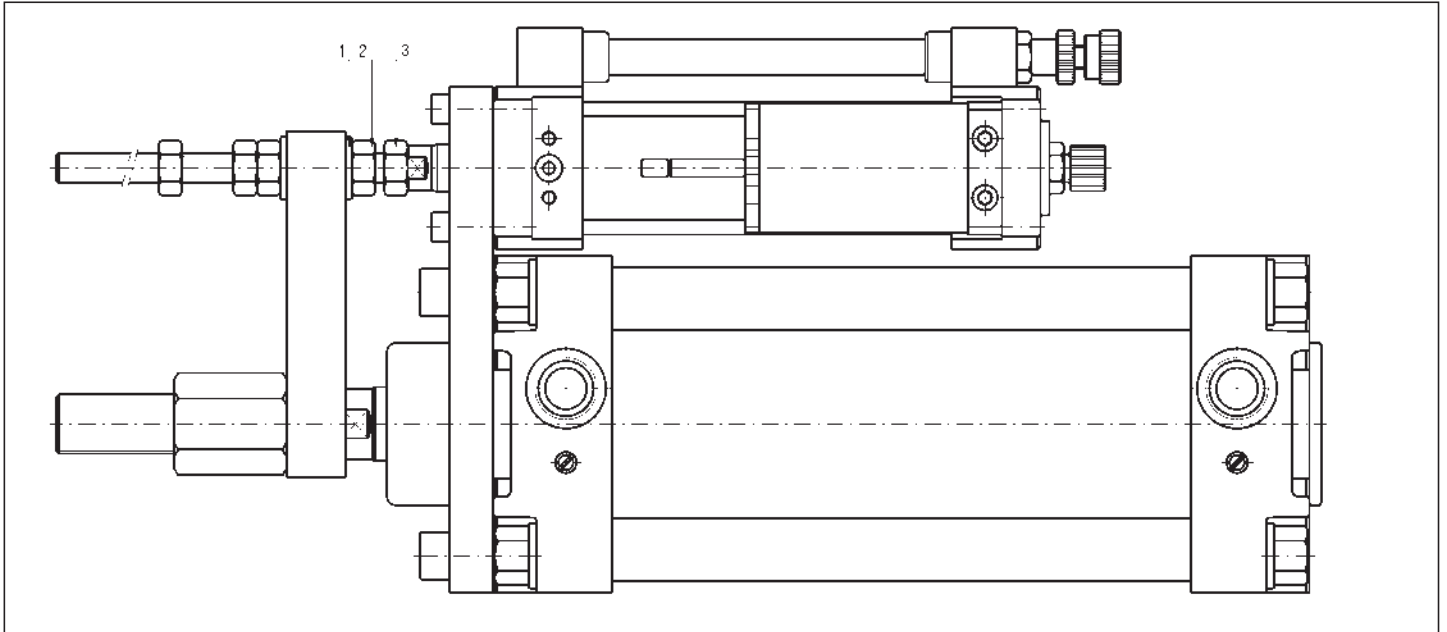

Ø	1	2	3
40 ÷ 63	-	X	-
80	-	X	X
100	X	X	X

P.S.: DO NOT TIGHTEN THE BRIDLE - THREADED BAR COUPLING

REINSTATEMENT PROCEDURE OF THE OIL LEVEL

HYDRAULIC SPEED REGULATORS ARE CLOSED CIRCUIT SYSTEMS SUPPLIED WITH A TANK FOR THE COMPENSATION OF THE ROD VOLUME. THIS TANK IS DESIGNED TO FACE LITTLE FLUID LOSSES DURING THE WORKING. IN THE EVENIENCE THAT DURING THE WORKING THE LEAKAGE OF OIL OVERCOME THE QUANTITY OF OIL IN EXCESS IN THE TANK, THE REGULATOR MUST BE REFILLED. THIS OPERATION MUST BE DONE WHEN THE INDICATOR NOTCH SITUATED ON THE DIP-STICK IN THE COMPENSATOR TANK IS NO MORE VISIBLE WHEN THE MAIN ROD IS COMPLETELY EXTENDED. TO REFILL THE HYDRAULIC SPEED REGULATOR USE A STANDARD GREASING SYRINGE, THAT CAN BE EASILY FOUND IN THE MARKET. THIS SYRINGE HAS TO BE CHARGED WITH "WAIRSOL HS" OIL.

REFILLING OPERATION:

- 1) PUT THE HYDRAULIC REGULATOR IN VERTICAL POSITION WITH THE FILLING VALVE, SITUATED ON THE REAR END CAP, THAT HAS TO BE HIGH-FACING.
- 2) EXTEND COMPLETELY THE HYDRAULIC REGULATOR PISTON ROD.
- 3) APPLY THE SYRINGE, FILLED WITH OIL, TO THE CONICAL SLOT OF THE FILLING VALVE ABOVE MENTIONED.
- 4) PUMP THE OIL IN THE REGULATOR WITH THE SYRINGE PAYING ATTENTION THAT THE SAME SHOULDN'T GO COMPLETELY EMPTY DURING THE RECHARGE (IF THIS OCCURS, STOP AND TOPPING UP THE SYRINGE).
- 5) CHARGE TILL THE MINIMUM NOTCH DOESN'T EXCEED THE LEVEL OF THE COMPENSATOR DIP-STICK PLUG OF $5 \div 8$ mm.
- 6) OPERATE MORE TIMES THE REGULATOR MAIN PISTON ROD, TAKING CARE OF REGULATING THE CUSHIONINGS TO OBTAIN THE MAXIMUM SPEED.
- 7) WITH THE PISTON ROD COMPLETELY RETRACTED AND WITH THE CYLINDER ALWAYS IN VERTICAL POSITION, OPERATE THE CLOSING MUSHROOM OF THE FILLING VALVE WITH A SPIKY TOOL SO THAT POSSIBLE AIR BUBBLES CAN BLEED.
- 8) REPEAT THE OPERATIONS FROM POINT No. 2 TO POINT No. 7 TILL THE AIR IN THE CIRCUIT WILL BE COMPLETELY ELIMINATED.

DESCRIPTION

Rotary cylinders series "WR" are fit to transform the piston straightaway motion into rotative motion by means of the coupling between rack and pinion. In the standard version, rotary cylinders series "WR" can be supplied with magnetic sensors and with rotation angle adjustment.



TECHNICAL DATA

Operating pressure	1 ± 10 bar
Working temperature	0 ÷ +80 °C (-20 °C with dry air)
Fluid	Filtered, unlubricated or continuous lubricated compressed air
Versions	Male pinion Female pinion
Bore	Ø 32, 40, 50, 63, 80, 100, 125
Port size	Ø 32 = G 1/8 Ø 40 - 50 = G 1/4 Ø 63 - 80 = G 3/8 Ø 100 - 125 = G 1/2
Standard rotation	90°, 180°, 270°; 360°
Rotation angle adjustment	± 5°

MATERIALS

End caps	Aluminium alloy, cataphoresis-treated
Cylinder barrel	Extruded profile, 20 µm anodized aluminium alloy
Central body	Anodized aluminium alloy
Pinion bearing	Ø 32: bronze-teflon bearings Ø 40 ÷ 125: ball bearings
Rack	Normalized steel, square section
Rack guide shoe	Acetal resin
Decelerators ogives	Aluminium alloy
Piston	NBR rubber block with magnet
Seals	NBR rubber

ORDER KEY

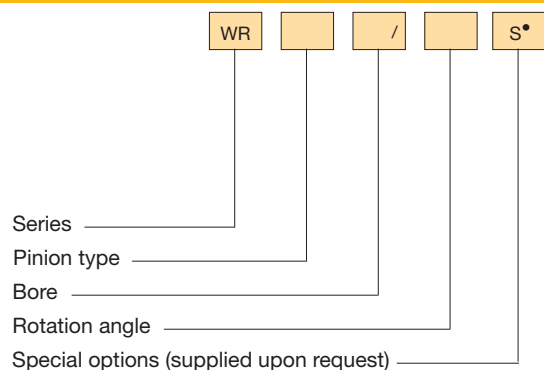

P.S.: Magnetic sensors FM 100 - FM 157 - FM 158 (see chapter magnetic sensors from page 1.93)
• See technical data on page 0.12

PINION TYPE

M Male pinion F Female pinion

ROTATION ANGLE

90°, 180°, 270°, 360°

TECHNICAL SPECIFICATIONS

Following table shows the torques of different rotary cylinders sizes, at the pressure of 1 bar.

This value has to be multiplied for the utilization bars to set the effective torque.

Ø	32	40	50	63	80	100	125
Torque at 1 bar (Nm)	1,73	3,08	5,4	10,5	21,8	35,3	71
Max. axial load F1 with F=0 (N)	100	100	120	120	200	250	300

SPARE PARTS

SEALS KIT	
NBR	Ø/SG/WR

WR ROTARY CYLINDER

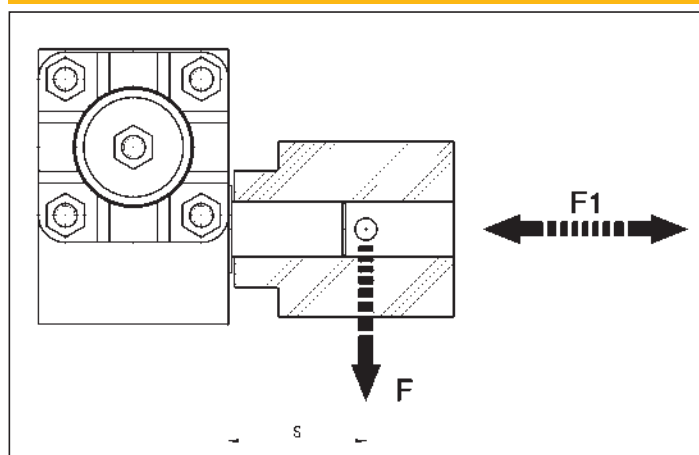

MAXIMUM PERMISSIBLE TRANSVERSE FORCE

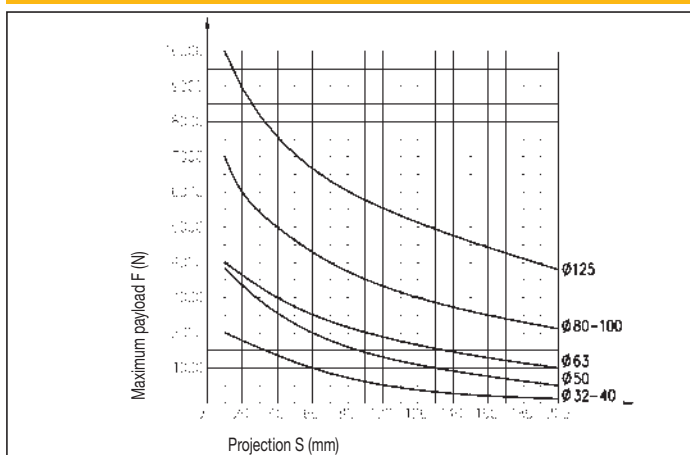

WR ROTARY CYLINDER

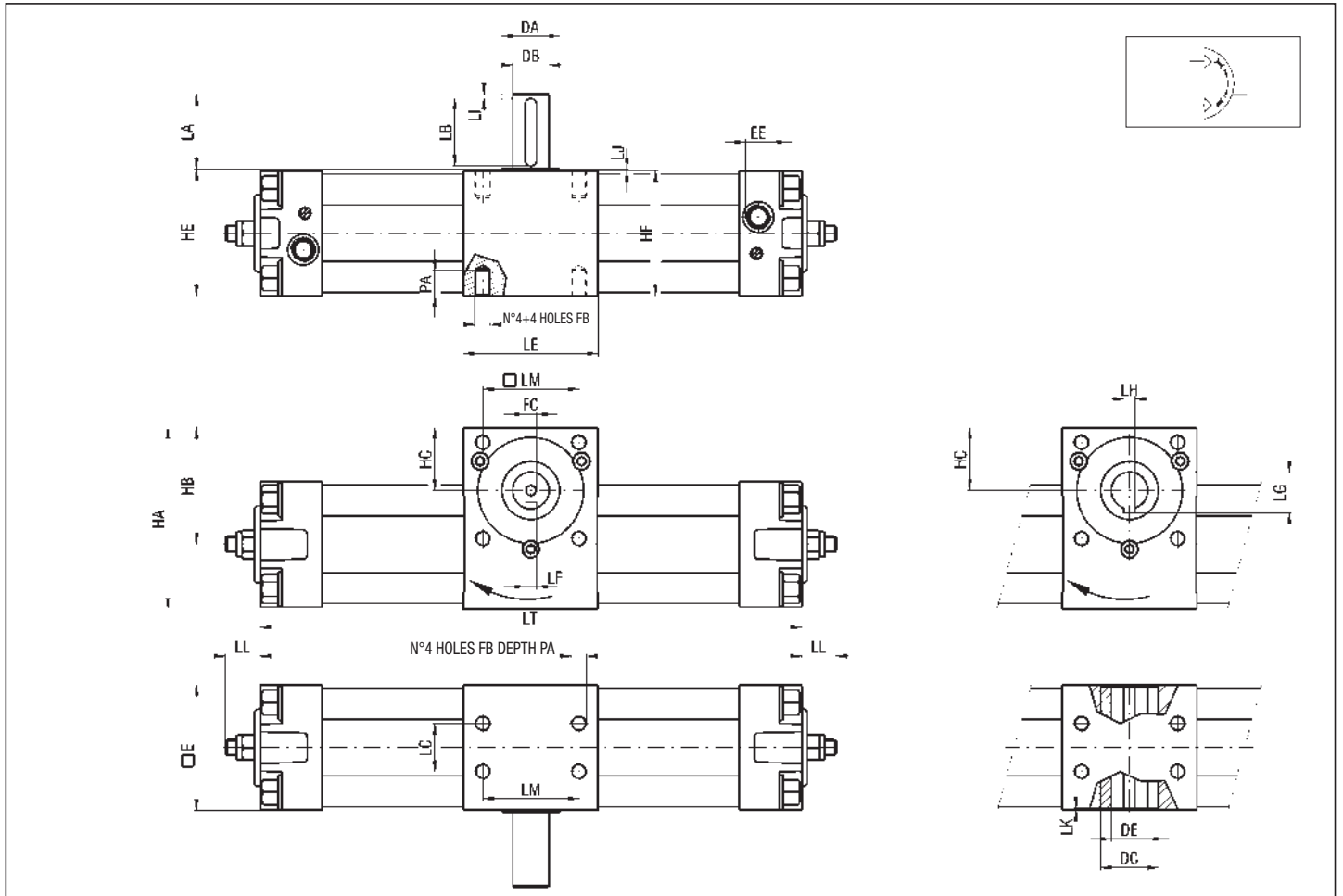

DIMENSIONS AND WEIGHTS

Ø	DA	DB g6	DC	DE H7	E	EE	FB	FC	HA	HB	HC	HE	HF	LA
32	25	14	25	14	47	G 1/8	M6	M5	71,5	46,5	25	51	50	30
40	25	14	25	14	54	G 1/4	M6	M5	82	54,5	30	61	60	30
50	30	19	30	19	65	G 1/4	M8	M6	94	60,5	32,5	66	65	40
63	30	24	30	19	75	G 3/8	M8	M8	110	70,8	37	76	75	40
80	45	28	45	24	95	G 3/8	M10	M8	142	93,5	50	100	99	50
100	50	38	50	28	114	G 1/2	M10	M10	156,5	99	54	116	115	50
125	60	38	60	28	140	G 1/2	M12	M10	188	118	60	141	140	50

Ø	LB	LC	LE	LF	LG	LH	LI	LJ	LK	LL		LM	PA
										min	max		
32	25	18	50	5	16,3	5	2,5	1	1	11	17	33	8
40	25	22	60	5	16,3	5	2,5	1	1	11	16	40	9
50	35	25	70	6	21,8	6	2,5	1	1	11	15	50	12
63	35	35	75	8	21,8	6	2,5	1	1	11	19	60	12
80	45	50	99	8	27,3	8	2,5	1	1	11	18	80	15
100	45	60	115	10	31,3	8	2,5	1	1	11	15	80	15
125	45	70	125	10	31,3	8	2,5	1	1	11	35	90	20

Ø	90° ROTATION ANGLE			180° ROTATION ANGLE			270° ROTATION ANGLE			360° ROTATION ANGLE		
	LT	PINION		LT	PINION		LT	PINION		LT	PINION	
		MALE WEIGHT (g)	FEMALE WEIGHT (g)		MALE WEIGHT (g)	FEMALE WEIGHT (g)		MALE WEIGHT (g)	FEMALE WEIGHT (g)		MALE WEIGHT (g)	FEMALE WEIGHT (g)
32	227,5	1300	1200	274,5	1420	1320	321,5	1540	1440	368,5	1660	1560
40	269	2010	1900	326	2210	2900	382,5	2390	2280	439	2580	2470
50	282	3070	2840	344,5	3340	3110	407,5	3610	3380	470	3880	3650
63	348	4990	4640	422,5	5500	5170	497	6010	5700	571,5	6520	6230
80	404	9840	9220	503	10840	10230	602	11840	11240	701	12840	12250
100	428	13650	12680	534,5	14860	13870	641,5	16070	15060	748	17280	16250
125	519	23370	22220	651	25720	24520	783	28070	26820	915	30420	29120

DESCRIPTION

Piston rod attachments, produced according to standards that regulate cylinders manufacturing, allow the cylinder piston rod to couple with the corresponding system that has to be enlivened.



FEMALE PISTON ROD CLEVIS WITH CLIPS TO ISO 8140 STEEL - M4 ÷ M20 X 1,5

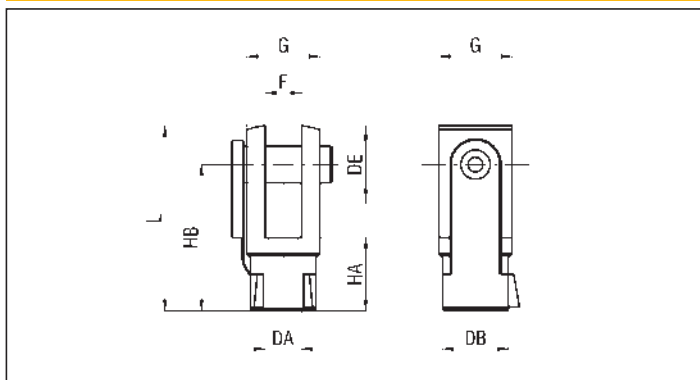

FEMALE PISTON ROD CLEVIS WITH PIN AND SNAP RING TO ISO 8140 - STEEL - M4 ÷ M36 X 2

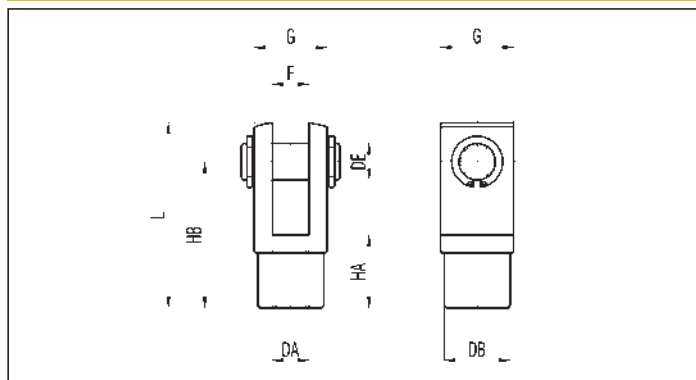

DIMENSIONS AND WEIGHTS

DA	DB	DE	F B12	G	HA	HB	L	WEIGHT (g)	CYLINDER SERIES and Ø					TYPE		
									U-UP	P-UP	BU7	CPU-X	CPUI	WITH CLIPS	WITH CLIPS	
M4	8	4	4	8	8	16	21	10	8-10						FF4	-
M6	10	6	6	12	12	24	31	18	12-16						FF6	FFP6*
M8	14	8	8	16	16	32	42	42	20						FF8	FFP8*
M10x1,25	18	10	10	20	20	40	52	90	25	32	20÷40	32	32	FF10x1,25	FFP10x1,25*	
M12x1,25	20	12	12	24	24	48	62	130		40	50-63	40	40	FF10x1,25	FFP12x1,25*	
M16x1,5	26	16	16	32	32	64	83	330		50-63	80	50-63	50-63	FF16x1,5	FFP16x1,5*	
M20x1,5	34	20	20	40	40	80	105	650			100	80-100	80-100	FF20x1,5	FFP20x1,5*	
M27x2	48	30	30	55	54	110	148	2100					125	-	FFP27x2	
M36x2	60	35	35	70	72	144	188	3900					160-200	-	FFP36x2	

* AISI 303 STAINLESS STEEL (SUPPLIED UPON REQUEST)

SELF-LUBRICATING PISTON ROD EYE TO DIN ISO 12240 STANDARD - STEEL

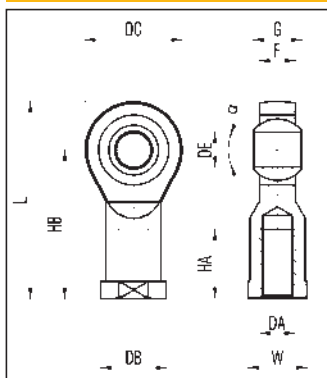

DIMENSIONS AND WEIGHTS

DA	DB	DC	DE H7	F	G	HA	HB	L	W	α	WEIGHT (g)	CYLINDER SERIES and Ø					TYPE
												U-UP	P-UP	BU7	CPU-X	CPUI	
M4	11	18	5	6	8	10	27	36	9	13	18	8-10					FF4/SS*
M6	13	20	6	6,75	9	12	30	40	11	13	26	12-16					FF6/SS*
M8	16	24	8	9	12	16	36	48	14	14	46	20					FF8/SS*
M10x1,25	19	28	10	10,5	14	20	43	57	17	13	76	25	32	20÷40	32	32	FF10x1,25/SS*
M12x1,25	22	32	12	12	16	22	50	66	19	13	110		40	50-63	40	40	FF12x1,25/SS*
M16x1,5	27	42	16	15	21	28	64	85	22	15	220		50-63	80	50-63	50-63	FF16x1,25/SS*
M20x1,5	34	50	20	18	25	33	77	102	30	14	409			100	80-100	80-100	FF16x1,25/SS*
M27x2	50	70	30	25	37	51	110	145	41	17	1200					125	FF27x2/SS
M36x2	58	80	35	28	43	56	125	165	50	16	1600					160-200	FF36x2/SS

* AISI 303 STAINLESS STEEL (SUPPLIED UPON REQUEST)

SELF-ALIGNING ROD COUPLER - GALVANIZED STEEL

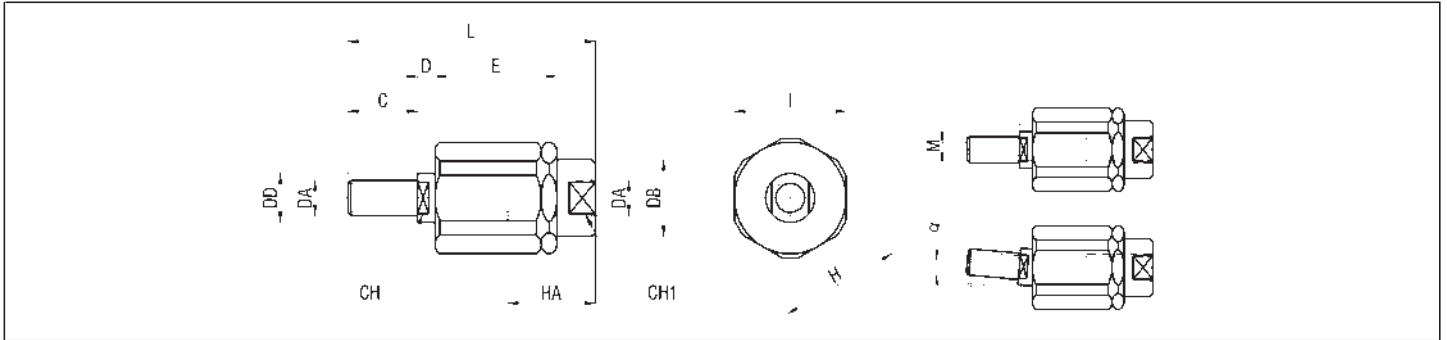

DIMENSIONS AND WEIGHTS

DA	C	CH	CH1	D	DB	DD	E	H	HA	I	L	M	α	WEIGHT (g)	CYLINDER SERIES and Ø					TYPE	
															U-UP	P-UP	BU7	CPU-X	CPUI		
M6	10	5	7	3,5	8,5	6	17,5	14,5	10	13	35	1	10	25	12-16						FF6/SA
M8	20	7	11	4	12,5	8	28,5	19	20	17	57	2	10	60	20						FF8/SA
M10x1,25	20	12	19	5	22	14	35	32	20	30	71	2	10	220	25	32	20÷40	32	32		FF10x1,25/SA
M12x1,25	24	12	19	5	22	14	35	32	20	30	75	2	10	230		40	50-63	40	40		FF12x1,25/SA
M16x1,5	32	20	30	8	32	22	54	45	32	41	103	2	10	660		50-63	80	50-63	50-63		FF16x1,5/SA
M20x1,5	40	20	30	8	32	22	54	45	40	41	119	2	10	700			100	80-100	80-100		FF20x1,5/SA
M27X2	54	24	54	10	57	32	60	70	40	65	147	2	8	1000					125		FF27x2/SA

FEMALE PISTON ROD CLEVIS WITH CLIPS TO DIN 71752 STANDARD - STEEL

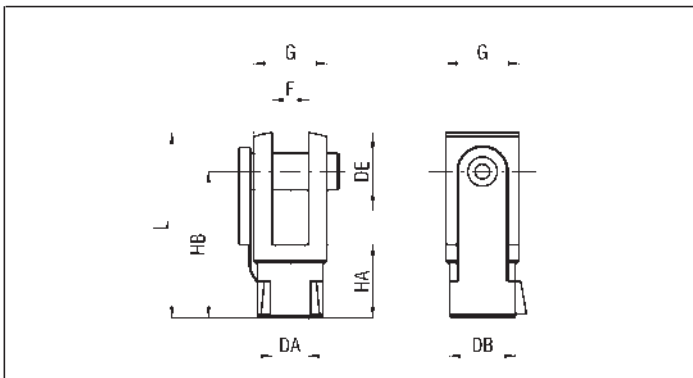

DIMENSIONS AND WEIGHTS

DA	DB	DE	F B12	G	HA	HB	L	WEIGHT (g)	CYLINDER SERIES HB	TYPE WITH CLIPS
									Ø	
M6	10	6	6	12	12	24	31	18	20	FF6
M8	14	8	8	16	16	32	42	42	27	FF8
M10	18	10	10	20	20	40	52	90	35-40	HB/FF10
M12	20	12	12	24	24	48	62	130	50	HB/FF12
M14	24	14	14	27	28	56	72	230	58	HB/FF14
M16	26	16	16	32	32	64	83	330	70	HB/FF16
M18	26	16	16	32	32	64	83	330	85	HB/FF18
M20	34	20	20	40	40	80	105	650	100	HB/FF20

1

FEMALE PISTON ROD CLEVIS WITH CLIPS
TO ex CNOMO 06 07 14 STANDARD - STEEL - M 10 ÷ M 27 x 2

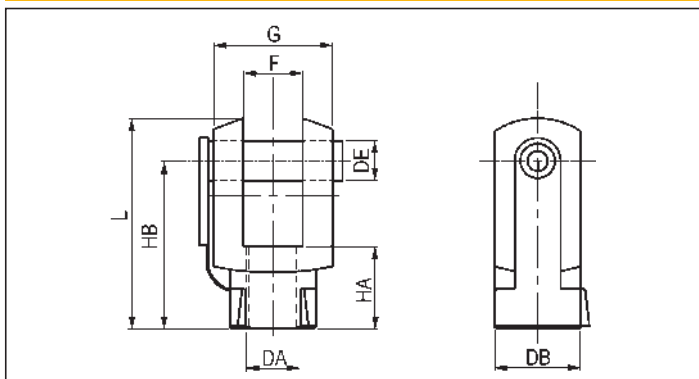

FEMALE PISTON ROD CLEVIS WITH PIN AND SNAP RING
TO ex CNOMO 06 07 14 STANDARD - STEEL - M 10 ÷ M 36 x 2

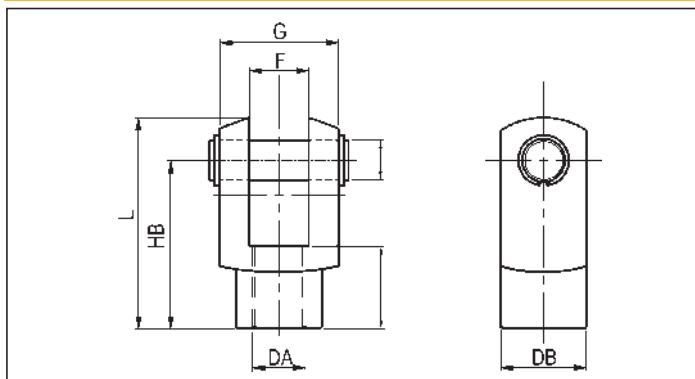

DIMENSIONS AND WEIGHTS

DA	DB	DE	F B12	G	HA	HB	L	WEIGHT (g)	CYLINDER SERIES CX	TYPE	TYPE
									Ø		
M10	18	8	11	22	20	36	45	80	32	CX/FF10	CX/FFP10
M16x1,5	26	12	18	36	26	51	64	210	40-50	CX/FF16x1,5	CX/FFP16x1,5
M20x1,5	34	16	22	45	30	63	80	440	63-80	CX/FF20x1,5	CX/FFP20x1,5
M27x2	42	20	30	63	45	85	105	910	100-125	CX/FF27x2	CX/FFP27x2
M36x2	50	25	40	80	75	115	140	1800	160-200	-	CX/FFP36x2

MALE PISTON ROD CLEVIS TO ex CNOMO 06 07 15 STANDARD - STEEL

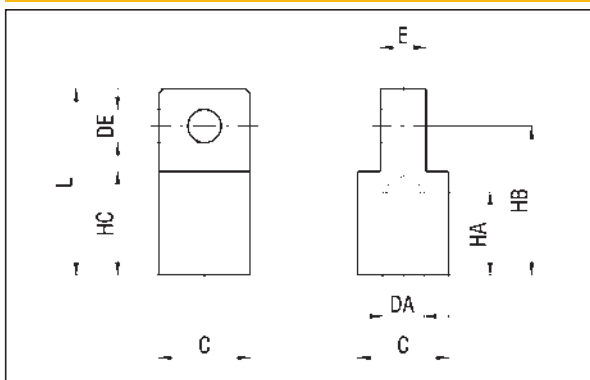

DIMENSIONS AND WEIGHTS

C	DA	DE H8	E f8	HA	HB H13	HC	L	WEIGHT (g)	CYLINDER SERIES CX	TYPE
									Ø	
22	M10	8	11	20	36	25	45	30	32	CX/FM10
32	M16x1,5	12	18	30	51	34	64	100	40-50	CX/FM16x1,5
36	M20x1,5	16	22	36	63	41	80	140	63-80	CX/FM20x1,5
45	M27x2	20	30	50	85	58	105	320	100-125	CX/FM27x2
63	M36x2	25	40	70	115	81	140	870	160-200	CX/FM36x2

ROD NUT

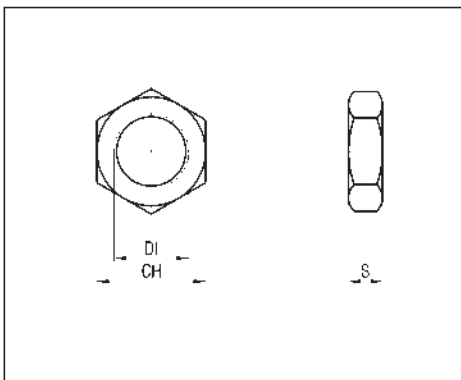

DIMENSIONS AND WEIGHTS

DI	CH	S	WEIGHT (g)	CYLINDER SERIES and Ø							TYPE STEEL	TYPE STAINLESS STEEL	
				U-UP	P-UP	BU7	CX	CPU-X	CPU1	B+NIPPLE			
M4	7	3	0,8	8-10								DST4	DSTI4
M6	10	4	1,48	12-16							12-16	DST6	DSTI6
M8	13	5	4	20							20-25	DST8	DSTI8
M10x1,25	17	6	8,6	25	32	20÷40					32-40	DST10x1,25	DSTI10x1,25
M10	17	6	8,6				32					DST10	DSTI10
M12x1,25	19	7	12,1		40	50-63					50-63	DST12x1,25	DSTI12x1,25
M16x1,5	24	8	20,1		50-63	80	40-50	50-63	50-63	50-63	G50÷80	DST16x1,5	UPDT16
M20x1,5	30	9	36,3			100	63-80	80-100	80-100	100		DST20x1,5	DSTI20x1,5
M27x2	41	12	90				100-125			125		DST27x2	DSTI27x2
M36x2	55	15	190				160-200			160-200		DST36x2	DSTI36x2