

High Speed Proportional Regulator

QKL- HS0、HS1、HS2



QKL-HS1. QKL-HS2 are 3-way electronic pressure regulators. It consists of proportional solenoid, pressure transducer, intelligent electronics, and a refined spool. It features high flow rate, extremely fast pressure switching time, high accuracy, and compatible with oxygen and hydrogen gas. Using the powerful in-house software, the control parameter can be customized that allows user to build unique pressure profile. It is available with analogue and digital command signal.

Ordering Code

QKL - □ - □ - □ - □

Type

HS0	Internal Feedback	G 1/4" G 3/8"
HS1	Internal Feedback	PT 1/4"
HS2	Internal Feedback	PT 1/2"

Input Signal

*E	0 - 10 V
A	4 - 20 mA
R	RS485 Modbus

Monitor Output

C	0 - 10 V
A	4 - 20 mA
R	RS485 Modbus

Body Material

A	Aluminum
B	Brass

*For Command Signal type 0-10V, the minimum driving current is 50mA.

*For cable length >2meter, please select current loop or RS485-modbus input signal.

High Speed Proportional Regulator

QKL- HS0、HS1、HS2



Specifications

Type	QKL-HS0		QKL-HS1		QKL-HS2	
Valve Type	3/2 Directly actuated seating valve					
Materials	Body brass or Aluminum, Mandrel stainless steel					
Seals	FKM					
Wetted Materials	Aluminum, Brass, Stainless steel, Viton(oxygen gas compatible), FFKM					
Mounting Bracket Material	Galvanized Steel					
Port	G 1/4"	G3/8"	PT 1/4"		PT 1/2"	
Output Pressure(bar)	0-10	*0-30	*0 – 30			
**Suggesting Supply Pressure Max(bar)	1.2 Times Output Pressure					
Power Supply	DC24V ±10% (≤40W)					
Input Signal	0-10V / 4-20mA/ RS485					
Monitor Output	0-10V / 4-20mA / RS485					
Flow Rate (ANR) NI/min	1600 @10 bar	6000 @30 bar	4,800 @30 bar		11,000 @30 bar	
Medium	Harmless gases, air, free of oil, condensate-free, hydrogen gas, oxygen(adiabatic compressor test performed)					
Recommended Filter	50 μm					
Mounting Position	Magnet must not face downwards					
IP Degree of protection	IP 54					
Weight	1 kg(Body Aluminum)		1.2 kg(Body Aluminum)		2 kg(Body Aluminum)	
Ambient Temperature	0 – 60 °C	Hysteresis			< 0.1 % FS	
Temperature of medium	0 – 60 °C	Response Sensitivity			< 0.1 % FS	
Operating Temperature	0 – 60 °C	Linearity			< 0.1 % FS	
Temperature Drift	< 1 % / 10K	Repeatability			< 0.1 % FS	
Long-term Drift	< 1 % FS/年 Year					

* Please contact us for customized pressure range.

** If the supply pressure would higher than we suggested, please contact with our sales for the the most suitable operation.

High Speed Proportional Regulator

QKL- HS0、HS1、HS2



Overall Dimension

QKL-HS0(10bar)

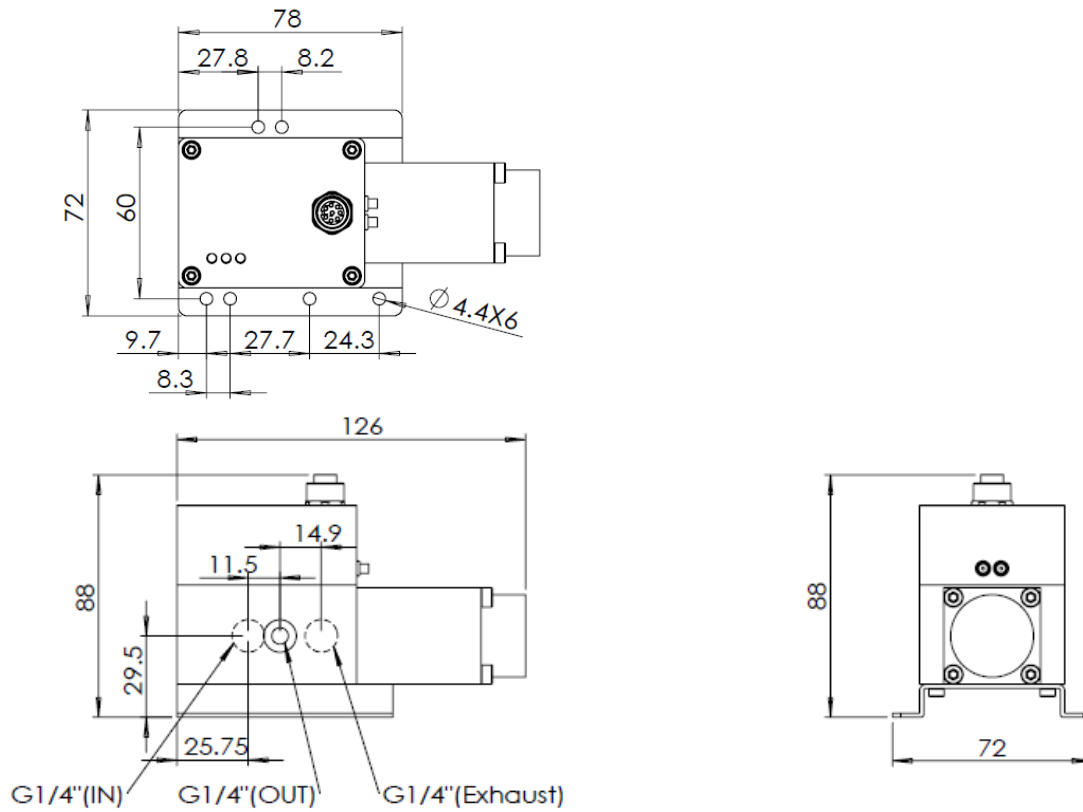

QKL-HS0(30bar)

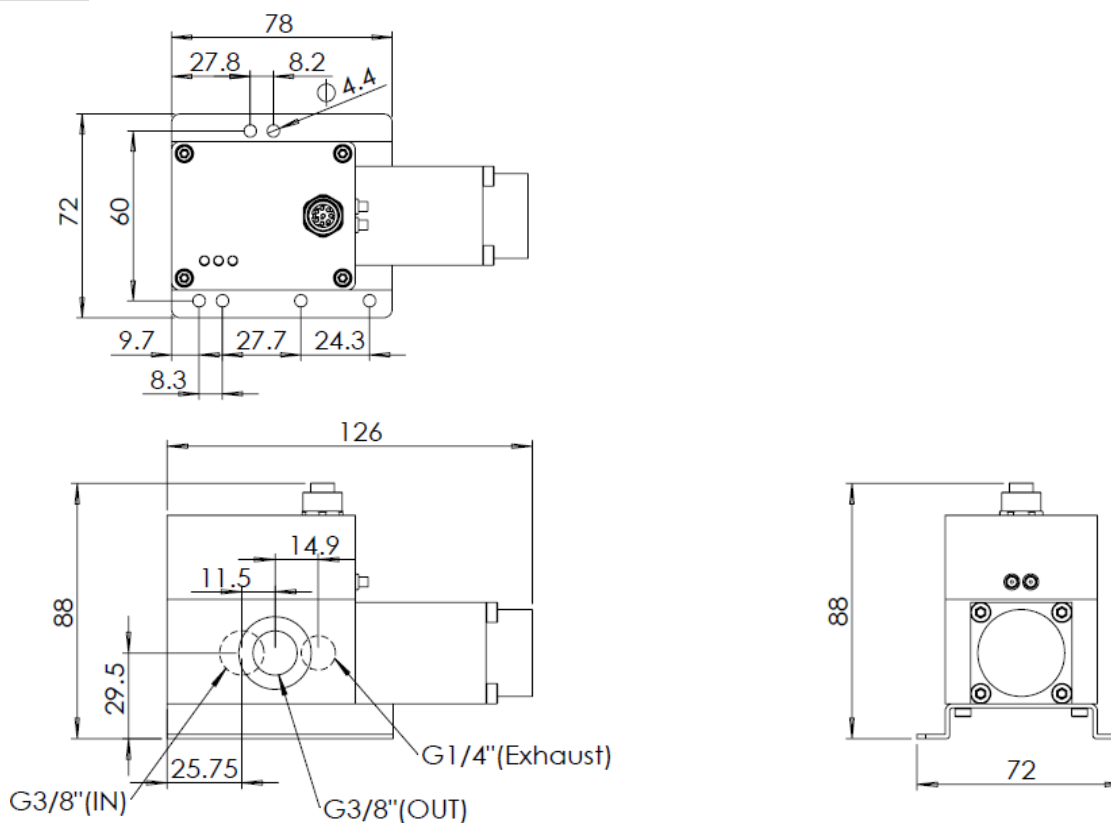

High Speed Proportional Regulator

QKL- HS0、HS1、HS2



Overall Dimension

QKL-HS1

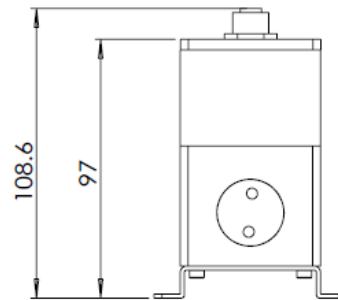
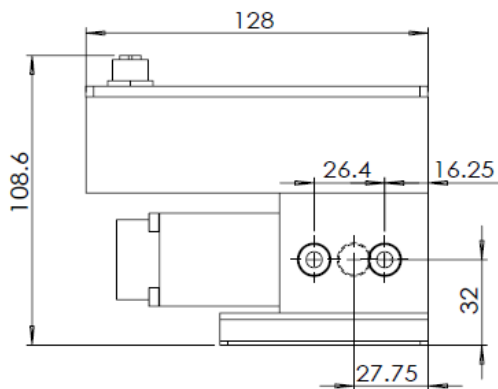
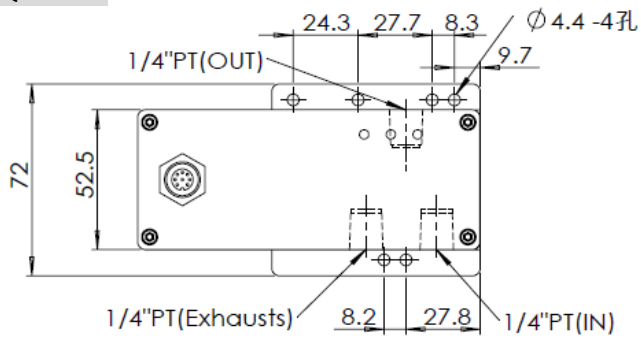

QKL-HS2

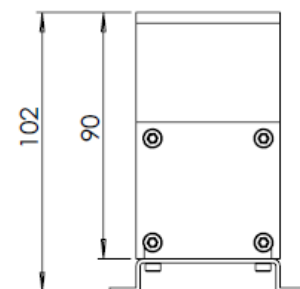
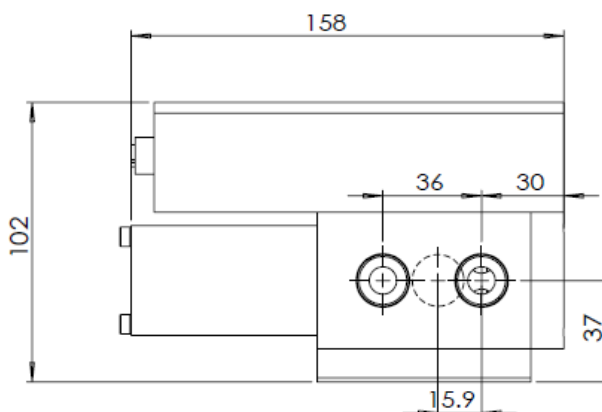
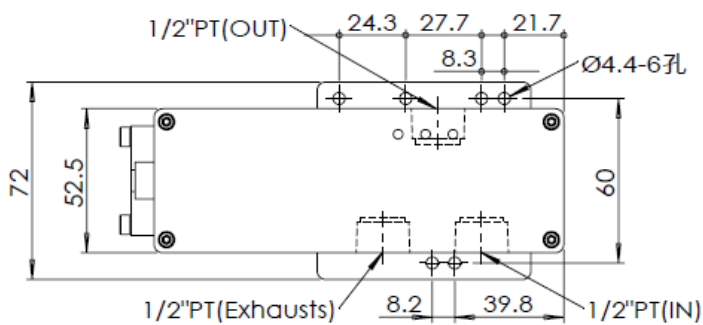

High Speed Proportional Regulator

QKL- HS0、HS1、HS2



Indicator LED Status

	<p>Power Supplying Light: LED on is power DC 24V normally supplied.</p>
	<p>Pressure Light: LED on means setting pressure reach the set value.</p>
	<p>Error Light :</p> <ol style="list-style-type: none"> LED flashing slowly(only available for QKL-HS1 and -HS2 series) -The supply voltage exceed DC30V or lower than DC20V. LED flashing fast(only available for QKL-HS1 and -HS2 series) -The temperature of valve body is over 70°C. LED stays on - Air pressure inlet is not supplied or insufficient.

Wiring Description

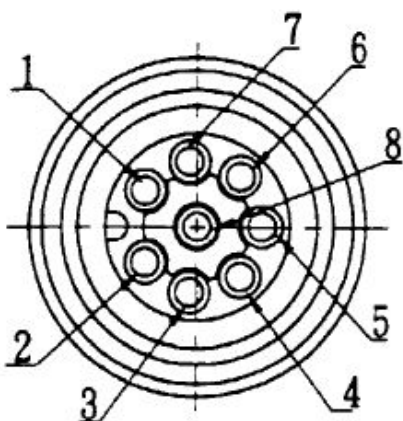

The wiring diagram shows from top view.

No.	Color	Function
1	Blue	24V DC Power (-)
2	Brown	24V DC Power (+)
3	Black	Monitor output (+)
4	White	0-10 V Command (+) 4-20 mA Command (+)
5	Gray	RS485(D-)
7	Purple	0-10 V Command (-) 4-20 mA Command (-) Monitor output (-)
8	Red	RS485(D+)

Warning: Do not rotate the connection socket when connected, to avoid damage to the internal sensor.

High Speed Proportional Regulator

QKL- HS0、HS1、HS2



Product Precautions



Read the operating manual carefully before installing and operating the product

Ignoring the safety instructions in the operating manual may result in malfunction of the product or a serious risk for the operator.



Connection, installation, operation, maintenance and dismantling of the product may only be carried out by qualified personnel



Pressurized systems

1. Pressure lines and screw connections must be adequately designed for the input pressure and output pressure of the valve.
2. Ensure that the pressure lines are connected properly to the input and output, before pressurizing the system.
3. Turn off the pressure supply, release the residual pressure, and remove all pressure connections before replacing or maintenance of the valve.



Danger of explosion

1. Do not operate the valve in rooms with flammable gases, steams or dust.
2. Do not use the control valve for the pressure control of flammable or explosive gases.



Risk of damage to the valve electronics

To avoid damages to the valve, please comply with the following notes:

1. Overvoltage may damage the electronics. Before turning on the valve, check the electrical connections and the supplied voltages carefully. Pay attention to the specified supply voltage range.
2. Lay the wires of the communication system and I/O device separately from power lines and servo motor cables.
3. Make sure the cables are adequately insulated. Use only cables that are suitable for the power consumption and ambient conditions of the valve.
4. Avoid repeatedly bending or stretching the cables or damaging the valve's housing.



Operating pressures greater than 10 bar of the stated pressure range may cause permanent damage to the sensor of the valve

Operate the valve only in the permissible pressure range, as specified in the technical specifications.



Electronic discharge may damage sensitive microelectronic components

1. Do not touch the electrical connections of the valve without sufficient electrostatic discharge (ESD) protection.
2. Follow the ESD protection instructions before opening the housing of the electronics.



The following conditions must be met for EMC compliance operation

1. Connect the shield connection, the plug and the equipment cabinet to ground accordingly.
2. Connect the valve body and the housing to the protective earth conductor (equipment grounding conductor).



Risk of damage to the valve

High Speed Proportional Regulator

QKL- HS0、HS1、HS2



To avoid damages to the valve please comply with the following notes:

1. In built-in position the valve magnet must not face downwards.
2. Tighten the connection between pressure lines and the valve correctly, otherwise resulting chips may damage the valve.
3. Pay attention to strong magnetic fields in order to avoid malfunctions.
4. Make sure that the pressure supply system is at least equipped with 50 µm filters.
5. Fluids containing condensate may cause malfunctions of the valve. Make sure that the pressure supply system is equipped with an air dryer, after cooler and an oil and water extractor.



Excessive heating of the magnet, due to the input pressure being less than or equal to the given set value or if the valve is operated without input pressure, may cause a decreasing accuracy of the sensor system and a shortened lifetime of the electronic components

1. Make sure that the valve is always pressurized with at least 1 bar more input pressure than the set value.
2. Switch on the input pressure first then enable the set value. Do not turn the input pressure on and off while the set value is activated.
3. Always switch off the set value before switching off the input pressure.



NOTICE

Warranty void if any label or serial number is changed, made illegible or removed.



NOTICE

Do not run control cables next to high-voltage lines, servo-motor cables, inverters...etc.



NOTICE

Technical data are subject to changes without further notice. Design may vary from the actual product.