

Series UM

General features - Direct acting solenoid valves side 15 mm.....	page	2.3
Accessories: bases	page	2.4

Series UL

General features - Direct acting solenoid valves side 32 mm	page	2.5
Accessories: bases	page	2.7

Series C/

General features - Direct acting solenoid valves with sleeve Ø 9 mm.....	page	2.9
Accessories: bases	page	2.11-12

Series USB - USBG

General features - Coils for solenoid valves	page	2.14
--	------	------

Series MEK192/N - USR102/N9 - ULR1B

General features - Connectors for solenoid valves	page	2.15
---	------	------

Series MEV

General features	page	2.16
Spool compact valves pilot and solenoid actuated 5 port - G 1/8	page	2.17
Spool compact valves solenoid actuated for single use or multi-pin plug connector 5 port - G 1/8	page	2.20
Accessories: bases G 1/8	page	2.21
Spool compact valves to VDMA 24563 standard pilot and solenoid actuated 5 port size 02	page	2.22
Spool compact valves to VDMA 24563 standard solenoid actuated for single use or multi-pin plug connector 5 port size 02	page	2.25
Accessories: single and manifold bases to VDMA 24563 standard size 02	page	2.26
Accessories: multi-pin connection with solenoid valves versions MEVX 8 and MEVX 18.....	page	2.28
Assembling examples: multi-pin connection with solenoid valves versions MEVX 8 and MEVX 18	page	2.30

Series MEK

General features	page	2.32
Spool compact valves pilot and solenoid actuated 5 port - G 1/8	page	2.33
Accessories: bases G 1/8	page	2.36
Spool compact valves pilot and solenoid actuated 5 port - G 1/4	page	2.37
Accessories: bases G 1/4	page	2.42

Series EK

General features	page	2.43
Spool valves pilot and solenoid actuated 3 and 5 port - G 1/8	page	2.44
Accessories: bases and supply rail for valves G 1/8.....	page	2.48
Spool valves pilot and solenoid actuated 3 and 5 port - G 1/4	page	2.49
Spool valves pilot actuated 5 port, "Namur" port pattern - G 1/4	page	2.51
Spool valves solenoid actuated 3 and 5 port - G 1/4	page	2.52
Spool valves solenoid actuated 5 port, "Namur" port pattern - G 1/4	page	2.54
Accessories: bases and supply rail for valves G 1/4	page	2.55
Spool valves pilot and solenoid actuated 3 and 5 port - G 1/2	page	2.56
90° Solenoid actuated valves - Mounting bracket for solenoid valves series EK with cylinders series CPU1.....	page	2.59

Series UK

General features	page	2.60
Poppet valves pilot and solenoid actuated 2, 3 and 5 port - G 1/8.....	page	2.62
Accessories: bases G 1/8	page	2.65
Poppet valves pilot and solenoid actuated 2, 3 and 5 port - G 1/4.....	page	2.66
Accessories: bases G 1/4	page	2.68
Poppet valves pilot and solenoid actuated 2, 3 and 5 port - G 1/2.....	page	2.69
Accessories: bases G 1/2	page	2.71
Poppet valves pilot and solenoid actuated 2, 3 and 5 port - G 1	page	2.72

Series UDS ISO

General features	page	2.74
Valves to ISO 5599/1 standard pilot and solenoid actuated size 1	page	2.75
Valves to ISO 5599/1 standard pilot and solenoid actuated size 2	page	2.77
Valves to ISO 5599/1 standard pilot and solenoid actuated size 3.....	page	2.79
Accessories: bases to ISO 5599/1 standard sizes 1 - 2 - 3.....	page	2.81

Series UDS CETOP

General features	page	2.86
Valves to ex CETOP RP 32 P standard pilot and solenoid actuated size 05 - 12 - 35	page	2.87
Accessories: bases to ex CETOP RP 32 P standard sizes 05 - 12 - 35	page	2.89

Series W

General features - Solenoid valves for media - G 1/8 ÷ G 2	page	2.91
Accessories: coils type WE.....	page	2.93

Series EV

General features - Vacuum valves solenoid (pilot assisted) actuated - G 1/8 ÷ G 2	page	2.94
---	------	------

Series VM

General features - Vacuum generators - G 1/8 ÷ G 1	page	2.96
--	------	------

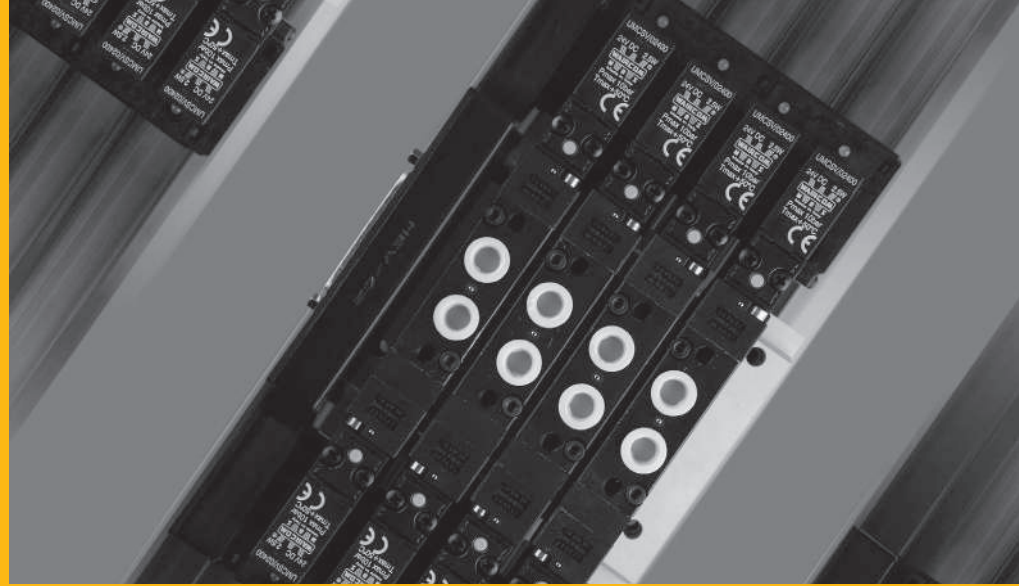

Waircom valves and solenoid valves: overview

Waircom valves and solenoid valves have been created according to different production philosophies in order to adapt to the different contexts in which they could be used. Thus, together with the historical poppet valves, have been manufactured throughout the ages different families of valves with spool construction, to be used individually, in manifold mounting or with multi-pin plug connector.

Even some series of this chapter comply with the international reference standards, and beside these, as usual we present a range of valves completely designed by ourselves, in according to the market needs. It's important to remember that some series of this valves can create the vacuum or work with this fluid, so that we can cover another share of the industrial market. Finally, even for the items belonging to this family exist some accessories like bases, coils, connectors and cables.

DESCRIPTION

The direct acting solenoid valves series "UM" are produced in conformity with the Directives EC 89/336, EC 92/31, EC 93/68, EC 73/23 in the 3/2 N.O. and 3/2 N.C. pneumatic functions. They are used as power valves if mounted on single and multi-station base, or as control valves if mounted, in the 3/2 pneumatic function, on body valve series "MEV" (see from page 2.16) and "MEK" (see from page 2.32).

The multi-station bases support both the 3/2 N.O. than the 3/2 N.C. solenoid valves. The wrapping could be rotated of 180° to have an opposite electric connection respect the manual override.

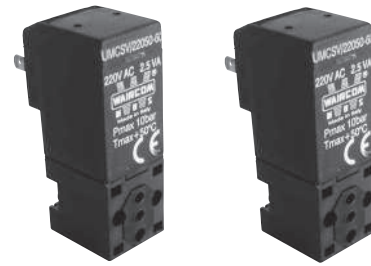

2

TECHNICAL DATA

Operatin pressure	0 ÷ 7 bar N.O. 0 ÷ 10 bar N.C.
Working temperature	-5° ÷ +50° C
Fluid	Filtered, unlubricated or continuous lubricated compressed air
Nominal diameter	1.1 mm N.C. - N.O.
Max. operating frequency	≤ 13 Hz
Coil	Integrated in the body
Voltages	DC: 12 - 24 V AC: 24 - 110 - 220 V
Power consumption	DC: 2.3 W AC: 2.8 VA (inrush) - 2.5 VA (holding)
Voltage tolerance	-5% +10%
Protection class	IP 65 with connector MEK 192/N with VDR
Solenoid rating	F (155°C)
Electric connector	MEK192/N - see chapter Connectors on page 2.15

MATERIALS

Core	Stainless steel AISI 430F
Body and manual override	Polyester thermoplastic
Springs	Stainless steel AISI 302
Seals	NBR rubber

FLOW CHART - UM

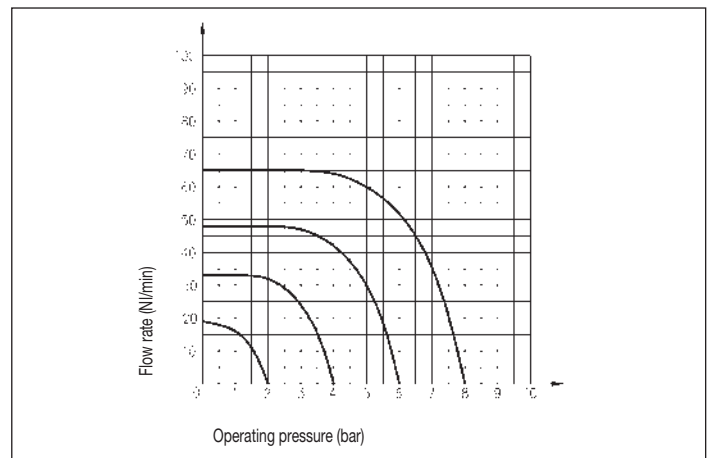

3 PORT WITH INTERFACE

Symbol	Function	Controls		Response time at 6 bar (ms)		Flow rate (Nl/min) at 6 bar ΔP = 1 bar	Manual override	Weight (g)	TYPE*
		Pilot	Return	Pilot	Return				
	3/2 N.O.	Solenoid	Mechanical spring	17	20	26	Monostable push button	40	UMASV/
	3/2 N.C.	Solenoid	Mechanical spring	13	23	30	Monostable push button	40	UMCSV/

* SPECIFY THE VOLTAGE IN THE ORDER
E.G.: UMCSV/02400

02400 = 24 V DC
02450-60 = 24 V AC

11050-60 = 110 V AC
22050-60 = 220 V AC

UMASV - UMCSV

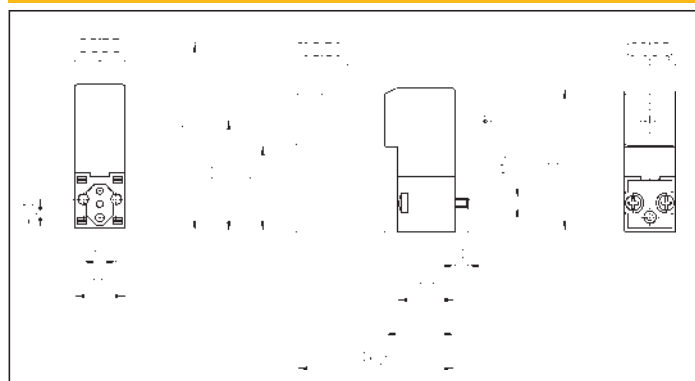

SINGLE BASE M5 - UMP5/1

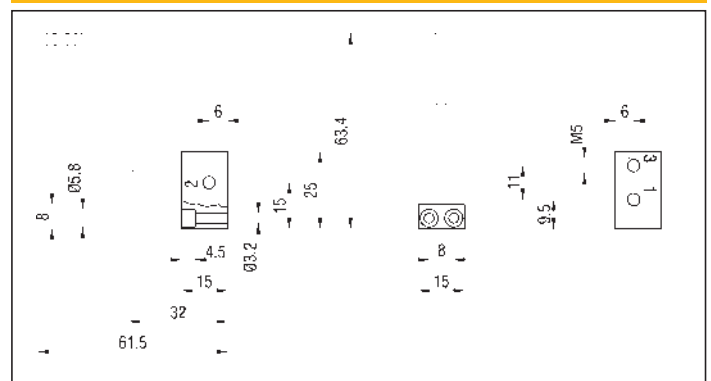

2

MULTI-STATION BASE M5 - UMPM5

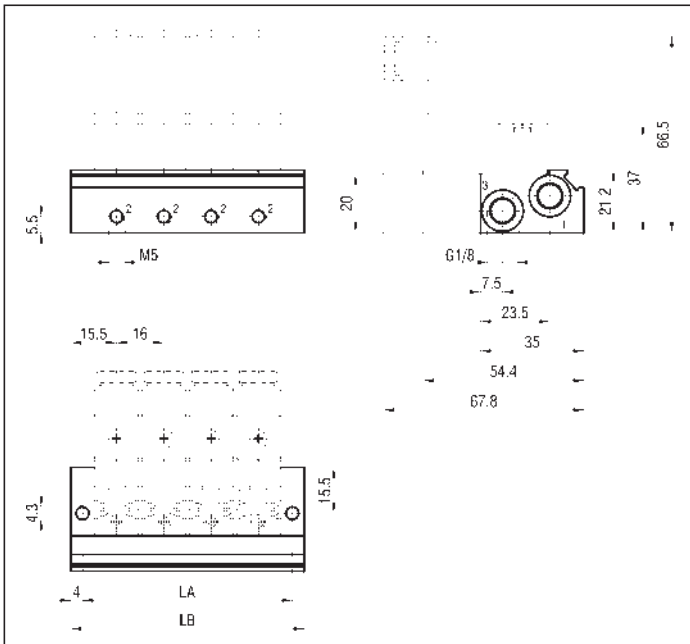

MULTI-STATION BASE WITH CARTRIDGE Ø 4 mm - UMP4-2

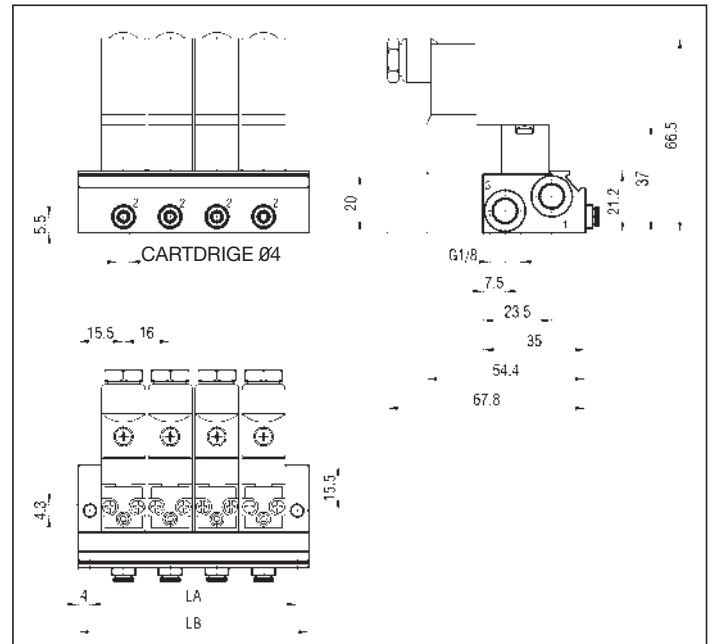

N° of stations	2	3	4	5	6	7	8	9	10
LA	39	55	71	87	103	119	135	151	167
LB	47	63	79	95	111	127	143	159	175
Weight (g)	70	95	120	145	170	195	220	245	270
TYPE	UMPM5/2	UMPM5/3	UMPM5/4	UMPM5/5	UMPM5/6	UMPM5/7	UMPM5/8	UMPM5/9	UMPM5/10
Weight (g)	75	100	125	150	175	200	225	250	275
TYPE	UMP4-2/2	UMP4-2/3	UMP4-2/4	UMP4-2/5	UMP4-2/6	UMP4-2/7	UMP4-2/8	UMP4-2/9	UMP4-2/10

REVERSAL PLATE - KIT/PC/UM

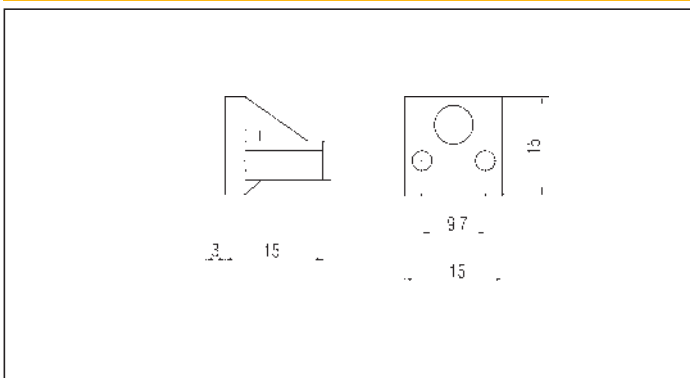

DESCRIPTION

The direct acting solenoid valves series "UL" are produced in conformity with the Directives EC 89/336, EC 92/31, EC 93/68, EC 73/23 in the 3/2 N.O. (with feed from the exhaust "3") and 3/2 N.C. pneumatic functions. The function 2/2 is obtainable closing exhaust "3". Besides are available the versions with ports G 1/8, suitable for single use, and with interface for multi-station base mounting or for mounting on poppet and to ex CETOP RP 32 P (with fixed position) valve bodies.

TECHNICAL DATA

Operating pressure	0 ÷ 10 bar
Working temperature	0 ÷ +50 °C (-20 °C with dry air)
Fluid	Filtered, unlubricated or continuous lubricated compressed air
Nominal diameter	2 mm
Max. operating frequency	≤13 Hz
Coil	Intergrated in the body
Voltages	DC: 24 V AC: 24 - 110 - 220 V
Apparent power	DC: 7 W AC: 17 VA (inrush) - 10 VA (holding)
Voltage tolerance	-15% +15%
Protection class	IP 65
Insulation class	F
Solenoid rating	ED 100%
Electric connector	ULR1B - see chapter Connectors on page 2.15

MATERIALS

Core	IMRE
Body ported G 1/8	Zamak
Body with interface	Glass stiffened polyamide (zamak upon request)
Springs	Stainless steel
Seals	Viton®
Manual override	Acetal resin



2

FLOW CHART - UL

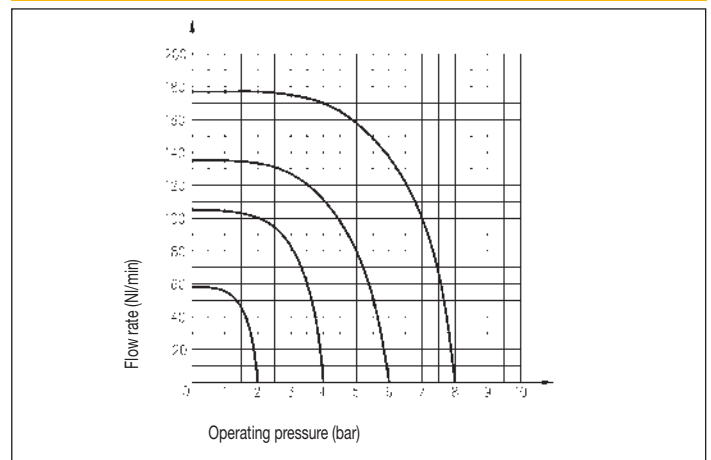

3 PORT G 1/8 SIDE 32 mm

Symbol	Function	Controls		Response time at 6 bar (ms)		Flow rate at 6 bar ΔP = 1 bar (Nl/min)	Manual override	Weight (g)	TYPE*
		Pilot	Return	Pilot	Return				
	3/2 N.O.**	Solenoid	Mechanical spring	15	20	80	-	240	ULARG/R
	3/2 N.C.	Solenoid	Mechanical spring	15	20	80	-	240	ULCRG/R
	3/2 N.O.**	Solenoid	Mechanical spring	15	20	80	Manual bistable	240	ULARV/R
	3/2 N.C.	Solenoid	Mechanical spring	15	20	80	Manual bistable	240	ULCRV/R

* SPECIFY THE VOLTAGE IN THE ORDER
E.G.: ULARG/R02450-60

02400 = 24 V DC 11050-60 = 110 V AC
02450-60 = 24 V AC 22050-60 = 220 V AC

** For version N.O. arrange the connections as indicated:

- 1 = EXHAUST
- 2 = OUTPUT
- 3 = INPUT

2

3 PORT G 1/8

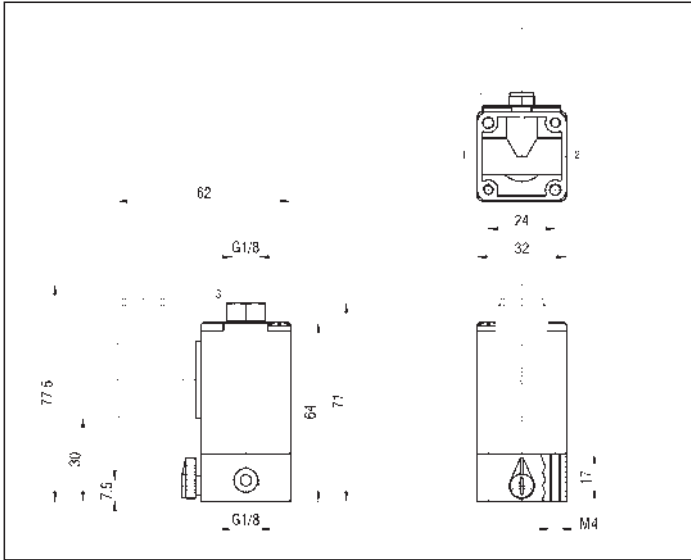

3 PORT WITH INTERFACE FOR MULTI-STATION BASES AND POPPET / ex CETOP VALVES (WITH FIXED POSITION)

Symbol	Function	Controls		Response time at 6 bar (ms)		Flow rate at 6 bar $\Delta P = 1$ bar (NI/min)	Manual override	Weight (g)	TYPE*
		Pilot	Return	Pilot	Return				
	3/2 N.O.	Solenoid	Mechanical spring	15	20	80	-	200	ULASG/R
	3/2 N.C.	Solenoid	Mechanical spring	15	20	80	-	200	ULCSG/R
	3/2 N.O.	Solenoid	Mechanical spring	15	20	80	Manual bistable	200	ULASV/R
	3/2 N.C.	Solenoid	Mechanical spring	15	20	80	Manual bistable	200	ULCSV/R

* SPECIFY THE VOLTAGE IN THE ORDER 02400 = 24 V DC 11050-60 = 110 V AC
 E.G.: ULARG/R02450-60 02450-60 = 24 V AC 22050-60 = 220 V AC

P.S. 1: For body valve in zamak add the letter "A" to the type.
 E.G.: 3/2 N.C. with manual override, body in zamak ULCSV/RA + voltage.
 P.S. 2: For body valve in plastic and universal interface strip change the letter "R" of the type with the letter "U".
 E.G.: 3/2 N.C. with manual override, body in plastic ULCSV/U + voltage.

3 PORT WITH PLASTIC INTERFACE STRIP

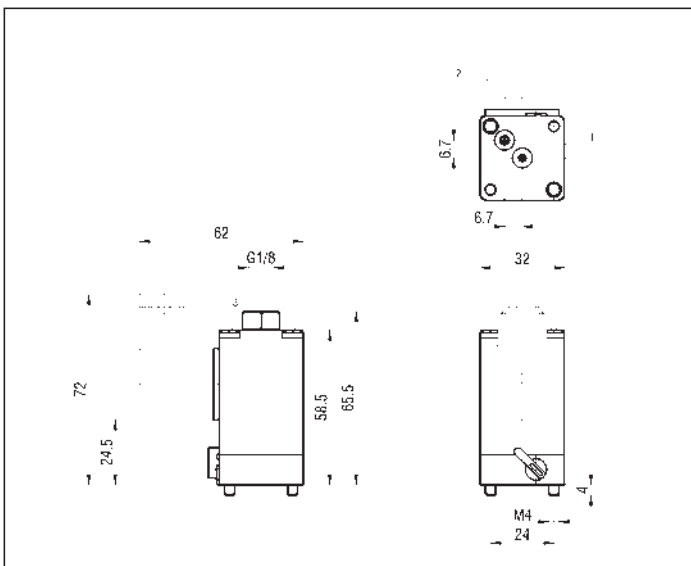

3 PORT WITH ZAMAK INTERFACE STRIP

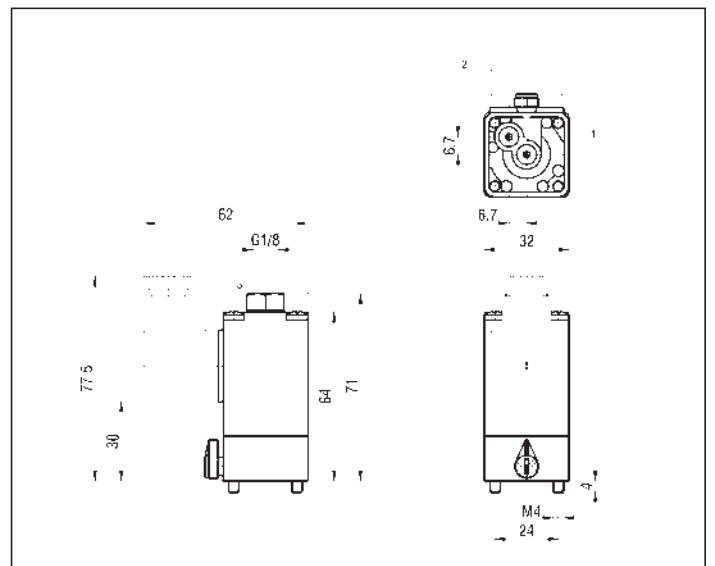

MULTI-STATION BOTTOM PORTED BASE G 1/8 - ULP8B

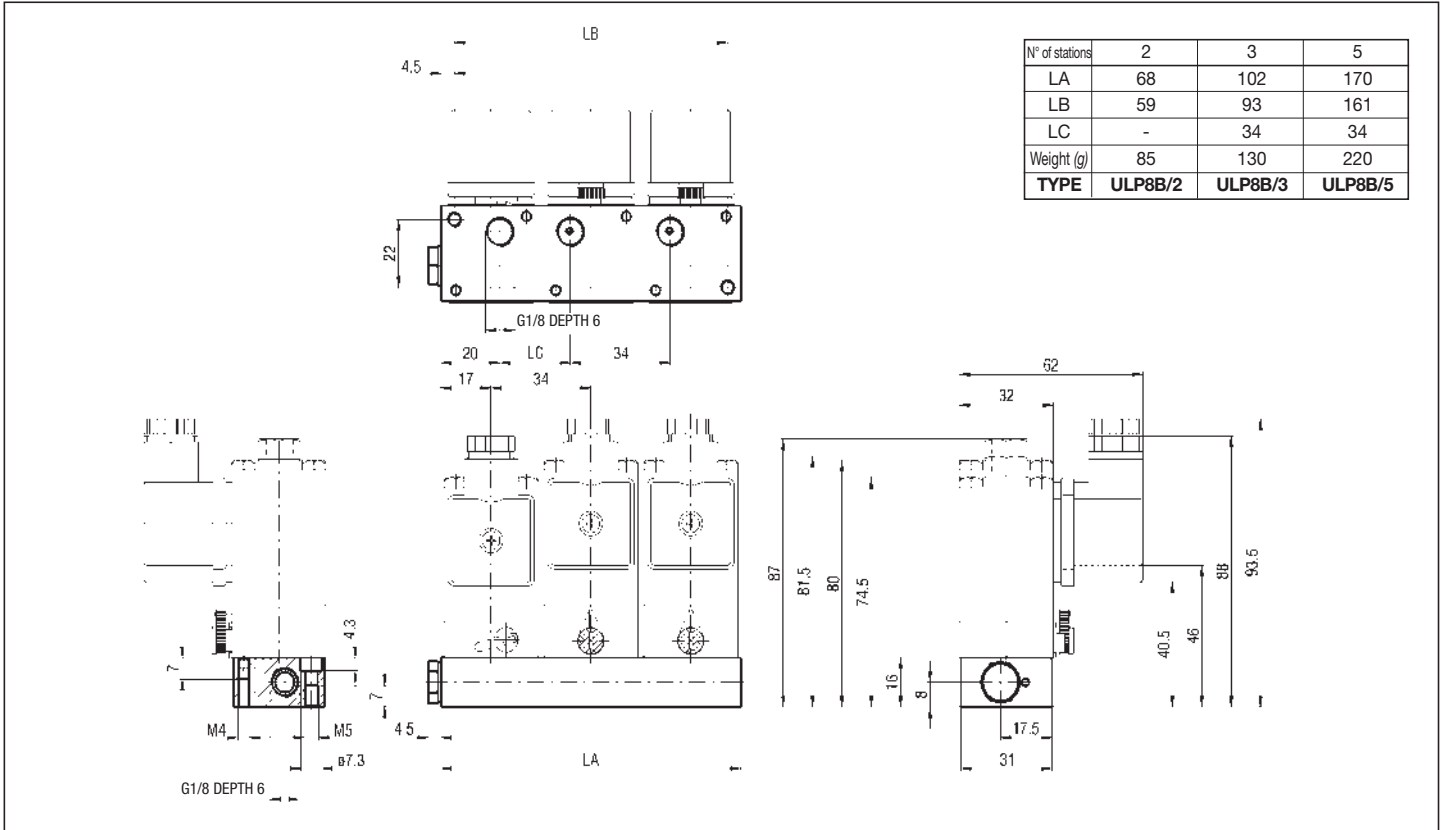

MULTI-STATION SIDE PORTED BASE G 1/8 - ULP8S

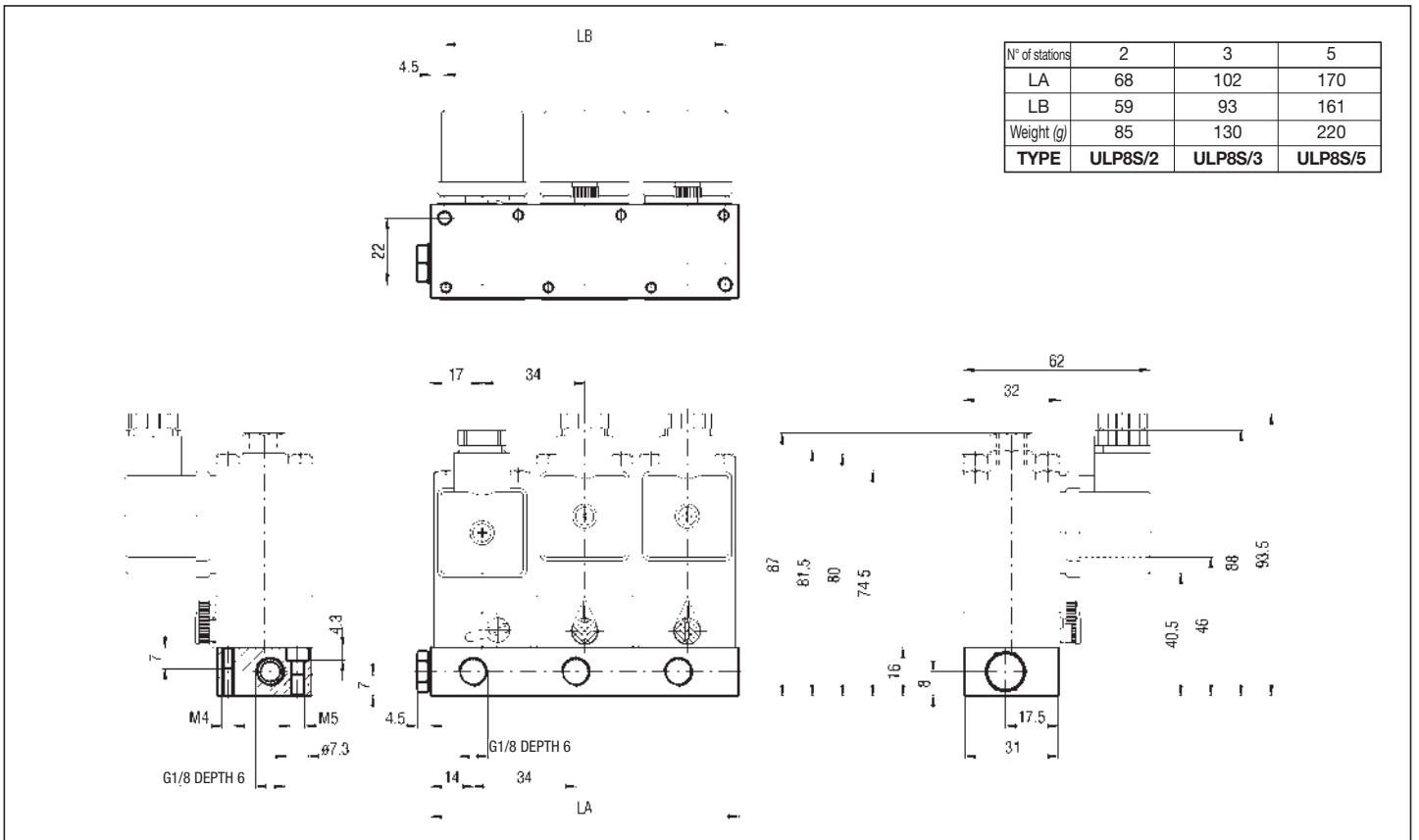

2

SINGLE BASE G 1/8 - XVB

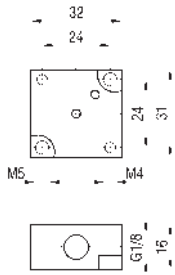

WEIGHT 40 g

BLANKING PLATE - KIT/PC/UL

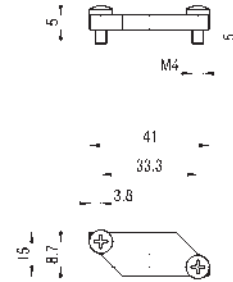

WEIGHT 10 g

EXAMPLE OF BASES ASSEMBLY

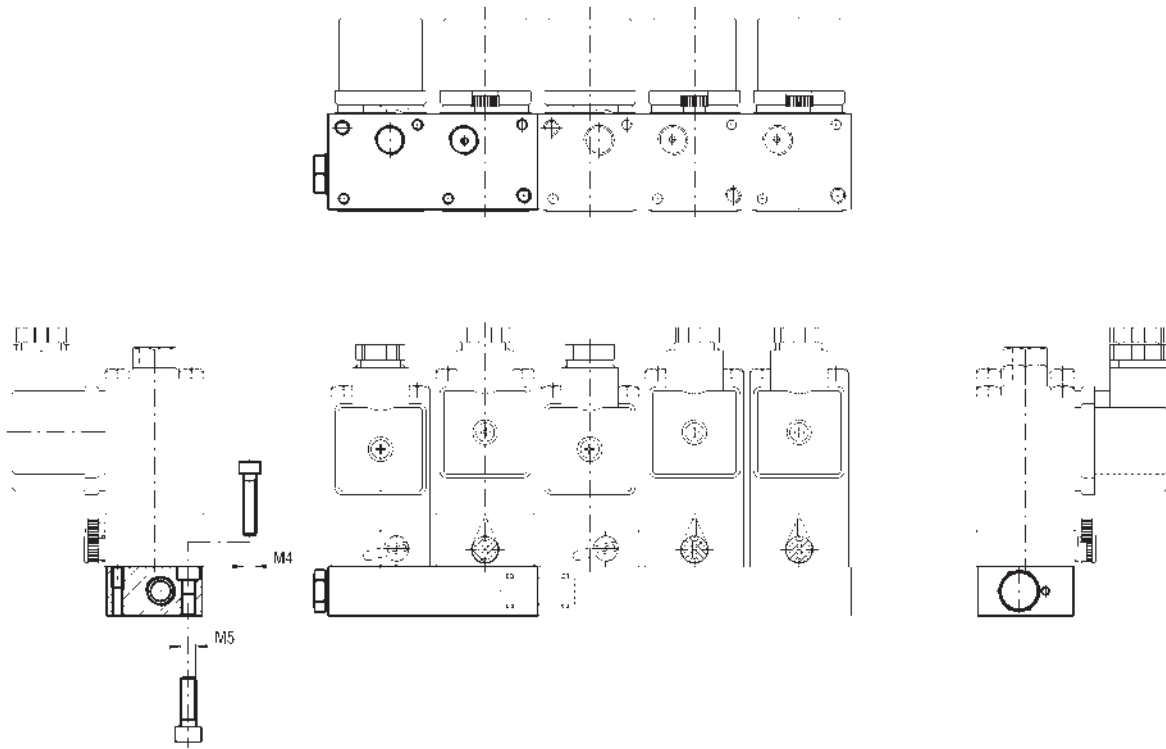

P.S.: The connection nipple is supplied as standard with the multi-station base

Direct acting solenoid valves with sleeve Ø 9 mm

series C/

DESCRIPTION

The direct acting solenoid valves series "C/" are produced in conformity with the Directives EC 89/336, EC 92/31, EC 93/68, EC 73/23 in the 3/2 N.O. and 3/2 N.C. pneumatic functions. Using the same mechanic, it is possible to obtain four standard versions: side 22 mm - body ported, side 22 mm - body with interface, side 30 mm - body with ex CNOMO interface and body with interface for mounting on poppet and ex CETOP (with fixed position and rotatable coil) valves. All the solenoid valves with interface can be mounted on single modular bases. The version side 30 mm with ex CNOMO interface, in the 3/2 N.C. pneumatic function, has two different manual overrides as standard: bistable screwdriver and monostable push button.

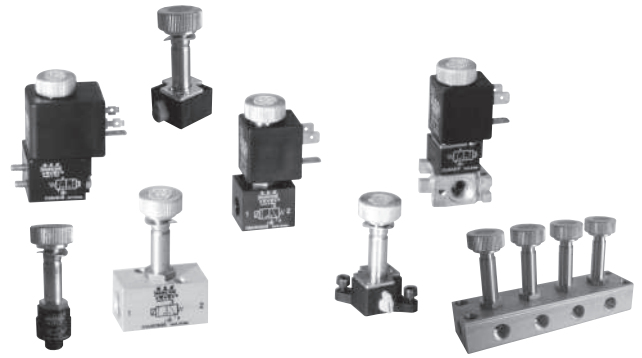

2

TECHNICAL DATA

Operating pressure	0 ÷ 10 bar N.C. 0 ÷ 8 bar N.O.
Working temperature	0 ÷ +50 °C (-20 °C with dry air)
Fluid	Filtered, unlubricated or continuous lubricated compressed air
Sleeve	Ø 9 mm
Nominal diameter	1,1 mm
Max. operating frequency	≤13 Hz
Coils	USB - see chapter Coils on page 2.14 USBG - see chapter Coils on page 2.14
Electric connectors	USR102/N9 - see chapter Connectors on page 2.15 ULR1B - see chapter Connectors on page 2.15

MATERIALS

Core	IMRE
Body ported G 1/8 - G 1/4	Aluminium
Body and manual override	Acetal resin
Springs	Stainless steel
Seals	Viton®

FLOW CHART - C/

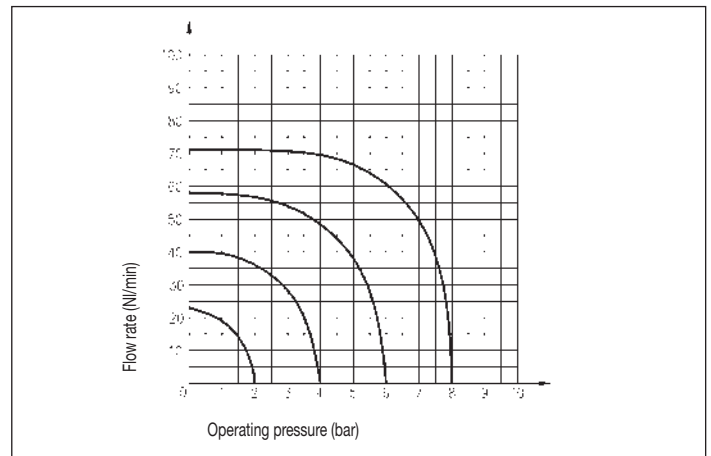

3 PORT G 1/8 - G 1/4 SIDE 22 mm

Symbol	Function	Controls		Response time at 6 bar (ms)		Flow rate at 6 bar ΔP = 1 bar (Nl/min)	Manual override	Size	Weight (g)	TYPE*
		Pilot	Return	Energized	De-energized					
	3/2 N.O.	Solenoid	Mechanical spring	10	20	48	G 1/8	-	46	C8/USASGG
	3/2 N.O.	Solenoid	Mechanical spring	10	20	48	G 1/4	-	46	C4/USASGG
	3/2 N.C.	Solenoid	Mechanical spring	10	20	36	G 1/8	-	65	C8/USCSGG
	3/2 N.C.	Solenoid	Mechanical spring	10	20	36	G 1/4	-	80	C4/USCSGG

* THE TYPES OF THE SOLENOID VALVES DO NOT INCLUDE COILS

2

3 PORT G 1/8

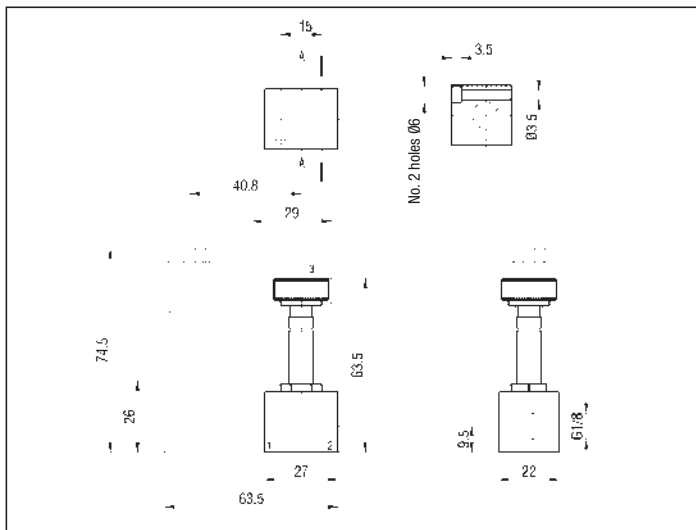

3 PORT G 1/4

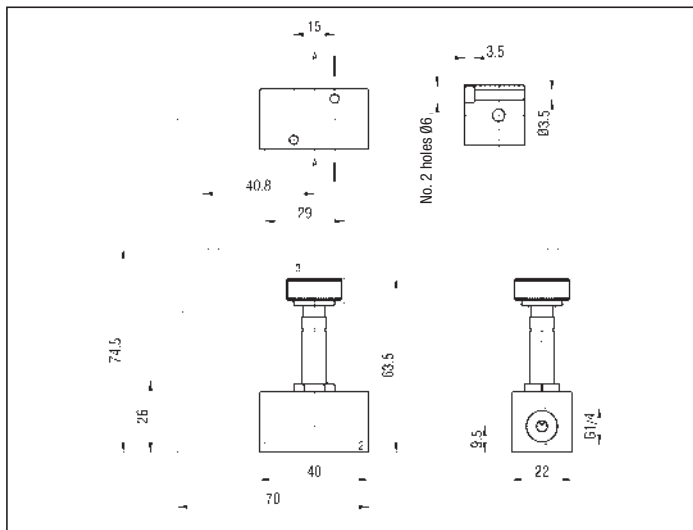

MANIFOLD BASE OF SOLENOID VALVES SIDE PORTED G 1/8 N.C. - C8/USCP AND N.O. - C8/USAP

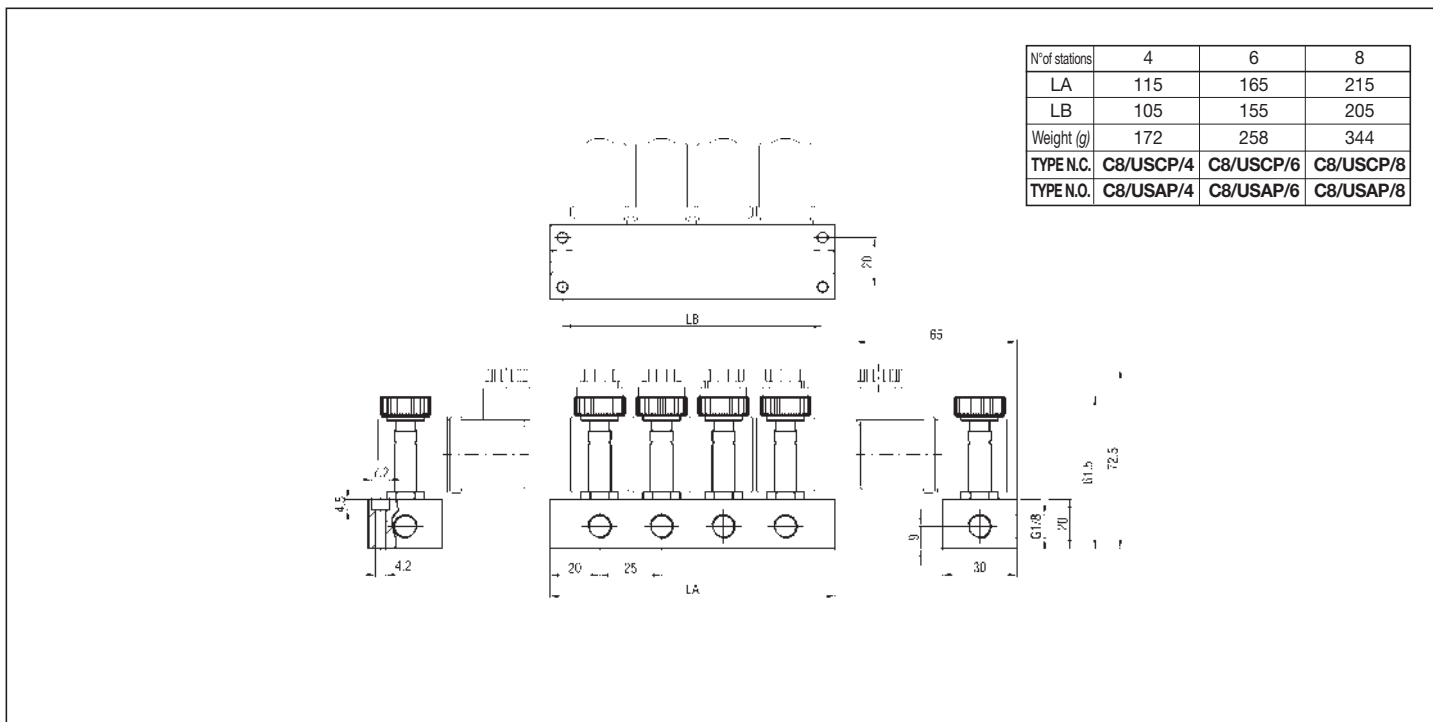

P.S.: MANIFOLD BASES OF SOLENOID VALVES WITH "MIXED" OPERATION (N.O./N.C.) ARE SUPPLIED UPON REQUEST

3 PORT WITH INTERFACE FOR MODULAR BASES AND SPOOL VALVES SIDE 22 mm

Symbol	Function	Controls		Response time at 6 bar (ms)		Flow rate at 6 bar $\Delta P = 1 \text{ bar}$ (l/min)	Manual override	Weight (g)	TYPE*
		Pilot	Return	Energized	De-energized				
	3/2 N.O.	Solenoid	Mechanical spring	10	25	36	Manual monostable	45	C/USASVP
	3/2 N.O.	Solenoid	Mechanical spring	10	25	36	-	30	C/USASGP
	3/2 N.C.	Solenoid	Mechanical spring	10	25	36	Manual monostable	30	C/USCSVP
	3/2 N.C.	Solenoid	Mechanical spring	10	25	36	-	30	C/USCSGP

* THE TYPES OF THE SOLENOID VALVES DO NOT INCLUDE COILS

C/USCSVP

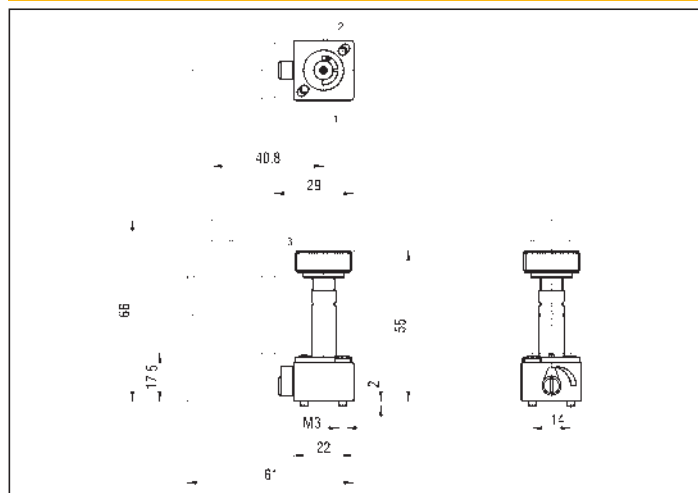

C/USASVP - C/USASGP

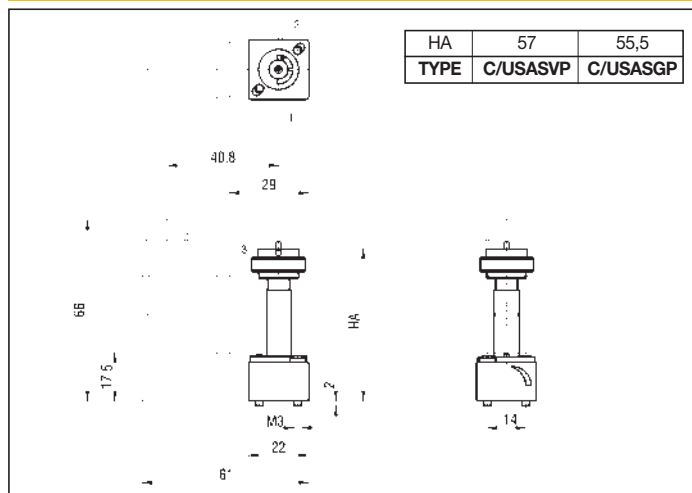

MODULAR BASE SIDE PORTED G 1/8 - ELPP8S

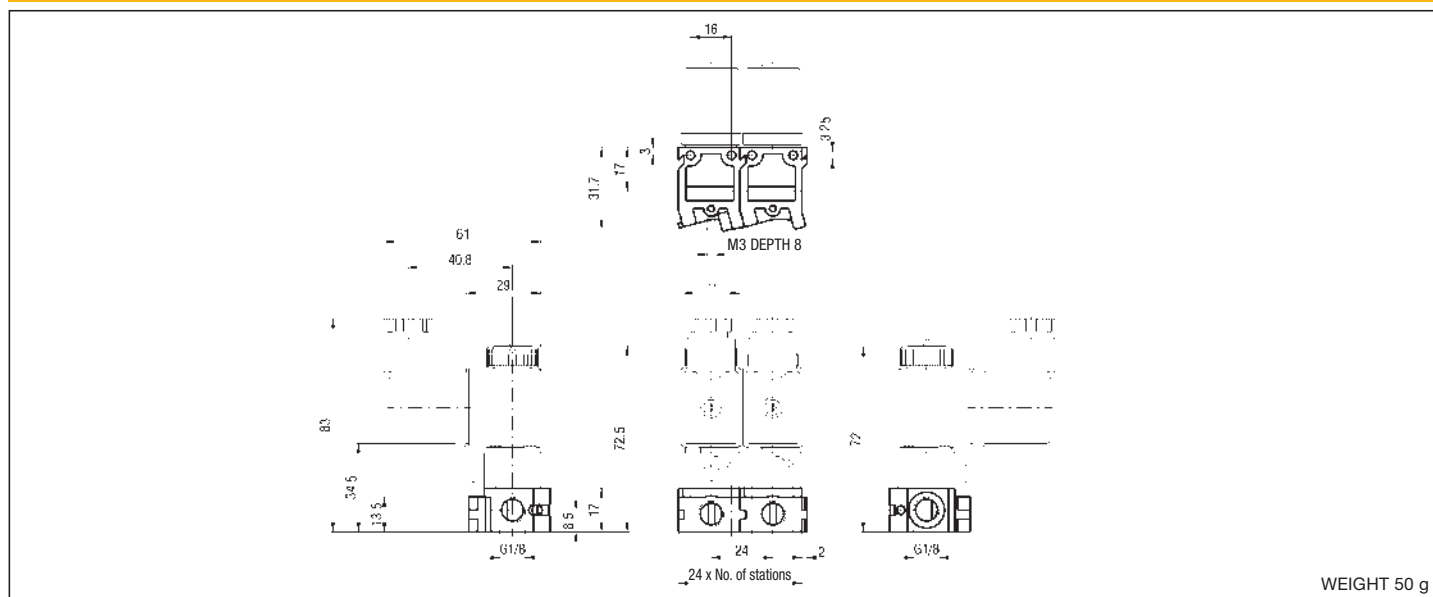

HOW TO ORDER A SOLENOID VALVE COMPLETE OF COIL AND BASE

Example: 3/2 N.C. solenoid valve base mounted (with manual override) + coil 24 V D.C. ELPP8S/P/USB/02400

DESCRIPTION	TYPE
3/2 N.O. + base + coil (with manual override)	ELPP8S/PAV/USB/voltage
3/2 N.O. + base + coil (without manual override)	ELPP8S/PAG/USB/voltage
3/2 N.C. + base + coil (with manual override)	ELPP8S/P/USB/voltage

3 PORT WITH ex CNOMO INTERFACE FOR MODULAR BASES AND VALVES TO ISO 5599/1

Symbol	Function	Controls		Response time at 6 bar (ms)		Flow rate at 6 bar $\Delta P = 1 \text{ bar (l/min)}$	Manual override	Weight (g)	TYPE*
		Pilot	Return	Energized	De-energized				
	3/2 N.O.	Solenoid	Mechanical spring	13	23	36	Manual monostable	60	C/UEASVB
	3/2 N.O.	Solenoid	Mechanical spring	13	23	36	-	45	C/UEASGB
	3/2 N.C.	Solenoid	Mechanical spring	10	25	36	Bistable screw driver slot	45	C/UECSVB
	3/2 N.C.	Solenoid	Mechanical spring	10	25	36	Monostable push button	45	C/UECSPB

* THE TYPES OF THE SOLENOID VALVES DO NOT INCLUDE COILS

C/UECSVB - C/UECSPB

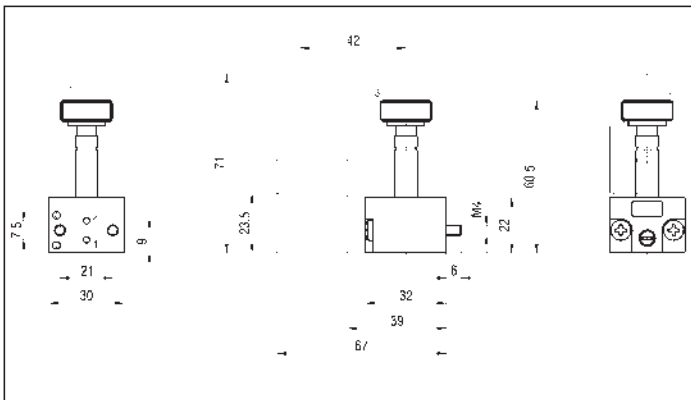

C/UEASVB - C/UEASGB

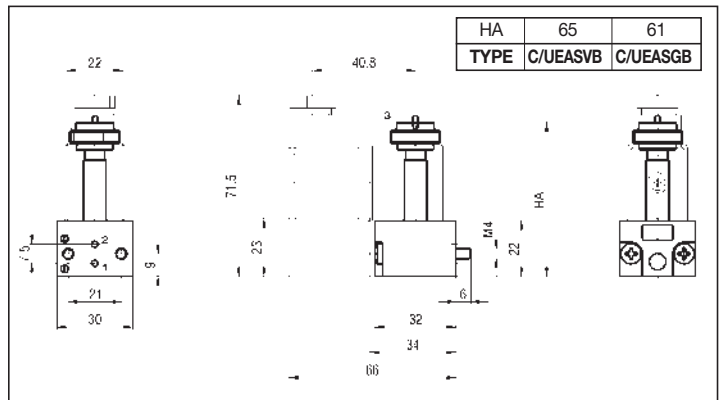

ex CNOMO MODULAR BASE SIDE PORTED G 1/8 - ELPG8S

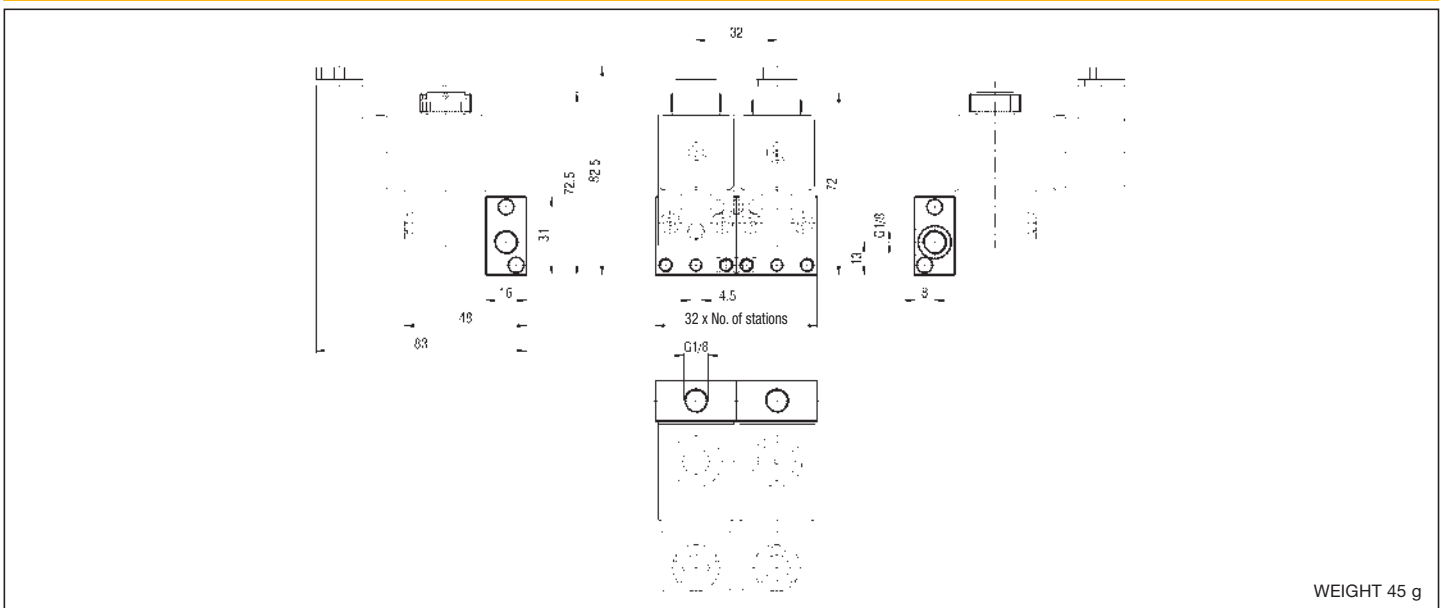

WEIGHT 45 g

HOW TO ORDER A SOLENOID VALVE COMPLETE OF COIL AND BASE

DESCRIPTION	TYPE
3/2 N.O. + base + coil (with manual override)	ELPG8S/BAV/USBG/voltage
3/2 N.O. + base + coil (without manual override)	ELPG8S/BAG/USBG/voltage
3/2 N.C. + base + coil (with manual override)	ELPG8S/B/USBG/voltage
3/2 N.C. + base + coil (with push button manual override)	ELPG8S/BP/USBG/voltage

Example: 3/2 N.O. solenoid valve base mounted (with manual override) + coil 24 V D.C. ELPG8S/BAV/USBG/02400

3 PORT WITH INTERFACE FOR POPPET AND ex CETOP (WITH FIXED POSITION AND ROTATABLE COIL) VALVES

Symbol	Function	Controls		Response time at 6 bar (ms)		Flow rate at 6 bar $\Delta P = 1$ bar (NI/min)	Manual override	Weight (g)	TYPE*
		Pilot	Return	Energized	De-energized				
	3/2 N.C.	Solenoid	Mechanical spring	10	25	36	Manual bistable	30	C/USCSVG

* THE TYPES OF THE SOLENOID VALVES DO NOT INCLUDE COILS

C/USCSVG

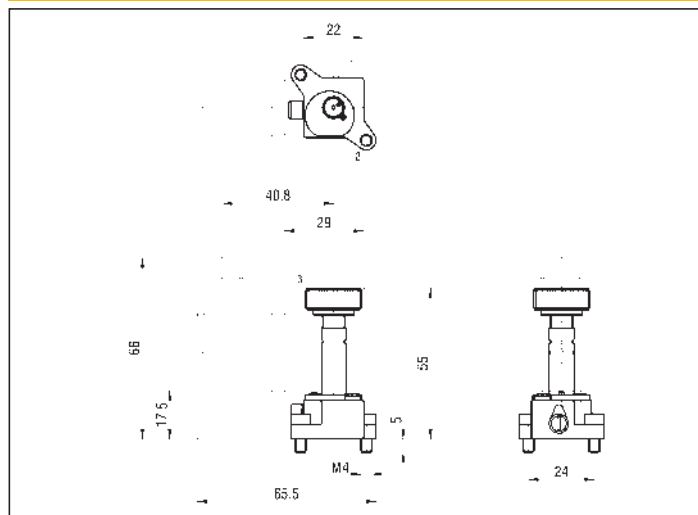

3 PORT BODY PORTED G 1/8 FOR DIRECT MOUNTING

This solenoid valve has been specifically designed to pilot single acting small cylinders and pneumatic valves. The input connection is M5 while the output has a male thread G1/8 that allows the direct assembling of the solenoid valve on the component.

Symbol	Function	Controls		Response time at 6 bar (ms)		Flow rate at 6 bar $\Delta P = 1$ bar (NI/min)	Manual override	Weight (g)	TYPE*
		Pilot	Return	Energized	De-energized				
	3/2 N.C.	Solenoid	Mechanical spring	10	20	36	-	46	C/ELP8M

* THE TYPES OF THE SOLENOID VALVES DO NOT INCLUDE COILS

C/ELP8M

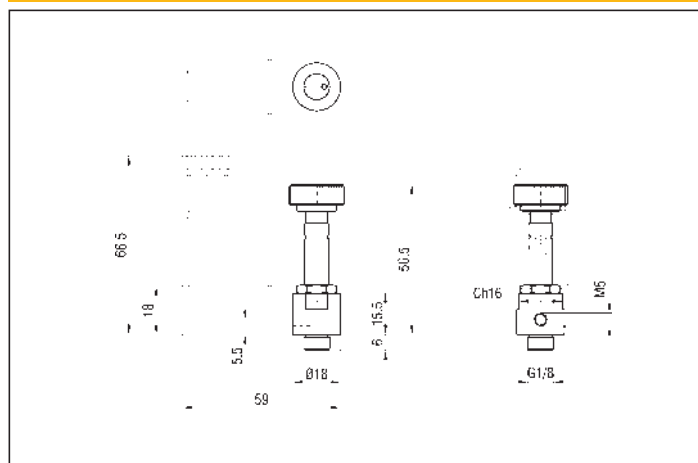

series USB

Coils for solenoid valves side 22 mm with sleeve Ø 9 mm

TECHNICAL DATA

Voltages	DC: 24 V AC: 24 V - 110 V - 220 V
Working temperature	-30 ÷ +40 °C basic version -30 ÷ +70 °C low absorption version
Power consumption	Basic version DC: 5 W AC : 11 VA (inrush) Low absorption version DC: 2,5 W AC: 5,6 VA (inrush)
Standard frequencies AC	50 - 60 Hz
Voltage tolerance	± 10% of rated voltage
Coil insulation class	F
Solenoid rating	100% ED
Electrical connection	Fit for connector to DIN 46244 standard See chapter Connectors series USR on page 2.15
Protection class with connector	IP 65

MATERIALS

Body	Glass stiffened polyamide
Coil winding	Copper wire

USB

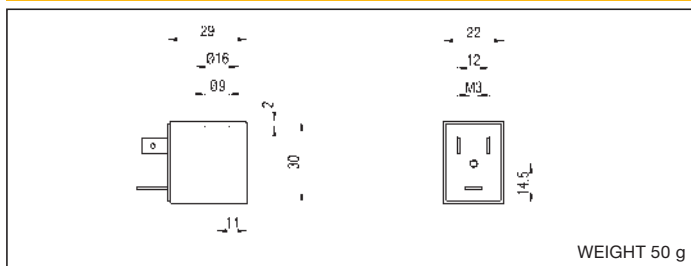

DESCRIPTION	TYPE
Coil 22 mm 24 V DC	USB/02400
Coil 22 mm 24 V AC	USB/02450-60
Coil 22 mm 110 V AC	USB/11050-60
Coil 22 mm 220 V AC	USB/22050-60
Coil 22 mm 24 V DC - low absorption	USB-BA/02400
Coil 22 mm 24 V AC - low absorption	USB-BA/02450-60
Coil 22 mm 110 V AC - low absorption	USB-BA/11050-60
Coil 22 mm 220 V AC - low absorption	USB-BA/22050-60
OTHER VOLTAGES	USB/...

series USBG

Coils for solenoid valves side 30 mm with sleeve Ø 9 mm to ex CNOMO standards

TECHNICAL DATA

Voltages	DC: 24 V AC: 24 V - 110 V - 220 V
Working temperature	-30 ÷ +40 °C basic version -30 ÷ +70 °C low absorption version
Power consumption	Basic version DC: 5 W AC : 11 VA (inrush) Low absorption version DC: 2,5 W AC: 5,6 VA (inrush)
Standard frequencies AC	50 - 60 Hz
Voltage tolerance	± 10% of rated voltage
Coil insulation class	H
Solenoid rating	100% ED
Electrical connection	Fit for connector to DIN 43650 standard, shape "A" See chapter Connectors series ULR on page 2.13
Protection class with connector	IP 65

MATERIALS

Body	Glass stiffened polyamide
Coil winding	Copper wire

USBG

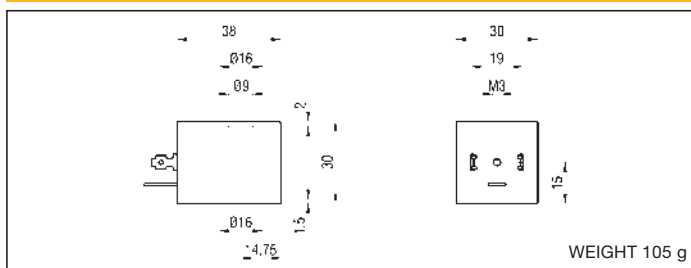

DESCRIPTION	TYPE
Coil 30 mm 24 V DC	USBG/02400
Coil 30 mm 24 V AC	USBG/02450-60
Coil 30 mm 110 V AC	USBG/11050-60
Coil 30 mm 220 V AC	USBG/22050-60
Coil 30 mm 24 V DC - low absorption	USBG-BA/02400
Coil 30 mm 24 V AC - low absorption	USBG-BA/02450-60
Coil 30 mm 110 V AC - low absorption	USBG-BA/11050-60
Coil 30 mm 220 V AC - low absorption	USBG-BA/22050-60
OTHER VOLTAGES	USBG/...

Connectors for solenoid valves side 15 mm series UM

series MEK192/N

TECHNICAL DATA	
Voltages	DC: MAX. 300 V AC: MAX. 250 V
Working temperature	-40 ÷ + 90 °C
Versions	Basic With indicator light (LED) With indicator light (LED) and varistat (VDR) as electrical protection
Number of pins	2 + earthed
Nominal current	6 A
Maximum current	10 A
Contacts resistance	≤ 4 mOhm
Protection class	IP 65 EN 60529
Connector insulation class	IEC 664 / VDE 0110-1/89

MEK192/N	
WEIGHT 10 g	
DESCRIPTION	TYPE
Basic connector	MEK192/N
Connector with led + VDR as protection 24 V DC/AC	MEK192/NVD 24V CC/CA
Connector with led + VDR as protection 110 V DC/AC	MEK192/NVD 110V CC/CA
Connector with led + VDR as protection 220 V DC/AC	MEK192/NVD 220V CC/CA
Connector with led 24 V DC/AC	MEK192/NLED 24V CC/CA
Connector with led 110/220 V DC/AC	MEK192/NLED 110/220V CC/CA

2

Connectors DIN 46244 for coils side 22 mm series USB and series WE (3A)

series USBR102/N9

TECHNICAL DATA	
Voltages	DC: MAX. 300 V AC: MAX. 250 V
Working temperature	-40 ÷ +90 °C
Versions	Basic With indicator light (LED) With indicator light (LED) and varistat (VDR) as electrical protection
Number of pins	2 + earthed
Nominal current	10 A
Maximum current	16 A
Contacts resistance	≤ 4 mOhm
Protection class	IP 65 EN 60529
Connector insulation class	IEC 664 / VDE 0110-1/89

USBR102/N9	
WEIGHT 20 g	
DESCRIPTION	TYPE
Basic connector	USBR102/N9
Connector with led + VDR as protection 24 V DC/AC	USBR102/N9VD 24 V CC/CA
Connector with led + VDR as protection 110 V DC/AC	USBR102/N9VD 110 V CC/CA
Connector with led + VDR as protection 220 V DC/AC	USBR102/N9VD 220 V CC/CA
Connector with led 24 V DC/AC	USBR102/N9LED 24 V CC/CA
Connector with led 110/220 V DC/AC	USBR102/N9LED 110/220 V CC/CA

Connectors DIN 43650 - form "A" for solenoid valves side 30 mm series UL and coils series USBG and series WE (2A, 5A)

series ULR1B

TECHNICAL DATA	
Voltages	DC: MAX. 300V AC: MAX. 250V
Working temperature	-40 ÷ + 90 °C
Versions	Basic With indicator light (LED) With indicator light (LED) and varistat (VDR) as electrical protection
Number of pins	2 + earthed
Nominal current	6 A
Maximum current	10 A
Contacts resistance	≤ 4 mOhm
Protection class	IP 65 EN 60529
Connector insulation class	IEC 664 / VDE 0110-1/89

ULR1B	
WEIGHT 25 g	
DESCRIPTION	TYPE
Basic connector	ULR1B
Connector with led + VDR as protection 24 V DC/AC	ULR1B/VD 24 V CC/CA
Connector with led + VDR as protection 110 V DC/AC	ULR1B/VD 110 V CC/CA
Connector with led + VDR as protection 220 V DC/AC	ULR1B/VD 220 V CC/CA
Connector with led 24 V DC/AC	ULR1B/LED 24 V CC/CA
Connector with led 110/220 V DC/AC	ULR1B/LED 110/220 V CC/CA

DESCRIPTION

Valves series "MEV" have been designed to satisfy the need of integration between pneumatics and electronics. Their main feature is the possibility to offer valve islands complete with the electrical connection. This series, realized in the 5/2 and 5/3 pneumatic functions, is composed of two types of valves:

"MEV 8", body ported G 1/8, prearranged for both single use and for mounting on multiple base with fixed stations;

"MEV 18" (size 02), to VDMA 24563 (UNI 10528) standards, prearranged for mounting on both single and manifold bases.

Both the multiple bases (that convey the exhaust port of the solenoid actuated electropilots) and the manifold ones are fit for mounting onto rails according to DIN 46277/3. For the 24 V AC/DC solenoid actuated valves with coils toward the bottom (versions "MEVX"), are available modules with two or four stations to carry out a multi-pin connection through a 25-pin plug with protection class "IP 65" (see technical information on page 0.4).

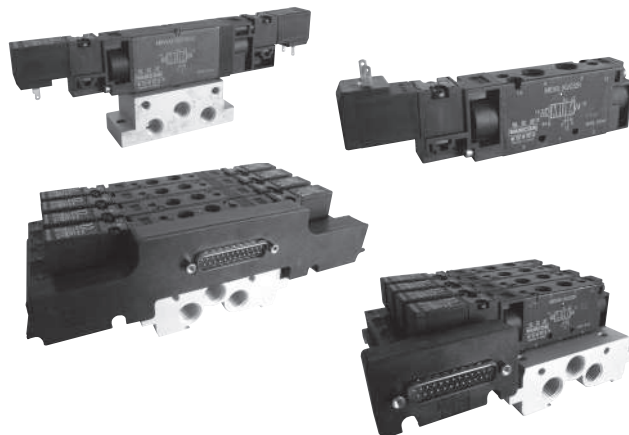

TECHNICAL DATA

Operating pressure	Monostable 1,8 ÷ 8 bar Bistable 1 ÷ 8 bar
Working temperature	0 ÷ +60 °C (-10 °C with dry air)
Fluid	Filtered, unlubricated or continuous lubricated compressed air
Port size	G 1/8 Size 02 = Interface to VDMA 24563 standard
Pneumatic piloting port size	G 1/8 = M5 Size 02 = Interface to VDMA 24563 standard
Nominal diameter	5 mm
Piloting solenoid valve	UMCSV - see chapter Direct acting solenoid valves page 2.3
Electric connectors	MEK 192/N - see chapter Connectors on page 2.15 See Multi-pin connection on page 2.28

MATERIALS

Bottoms	Plastic
Body	Anodized aluminium alloy treated with PTFE
Springs	Stainless steel
Seals	NBR rubber
Spool	Anodized aluminium alloy
Piston	Anodized aluminium alloy

SPARE PARTS

SEALS KIT	
5/2 monostable and bistable	MEV/SG
5/3 closed centre	MEV/CC/SG
5/3 open centre	MEV/CA/SG
5/3 pressure centre	MEV/CP/SG

FLOW CHART - MEV/8

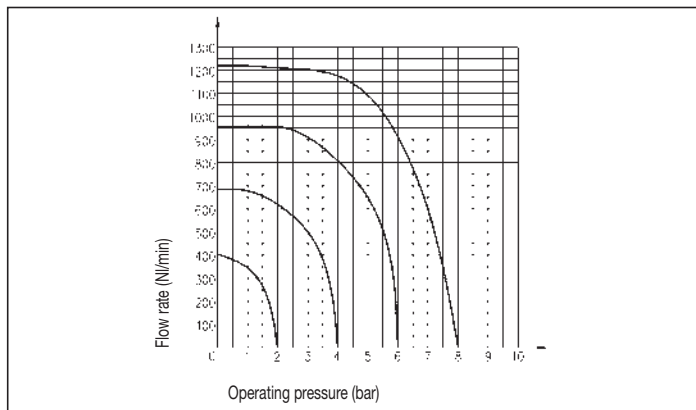

PILOTING CHART - MEV/8 - MEV/18

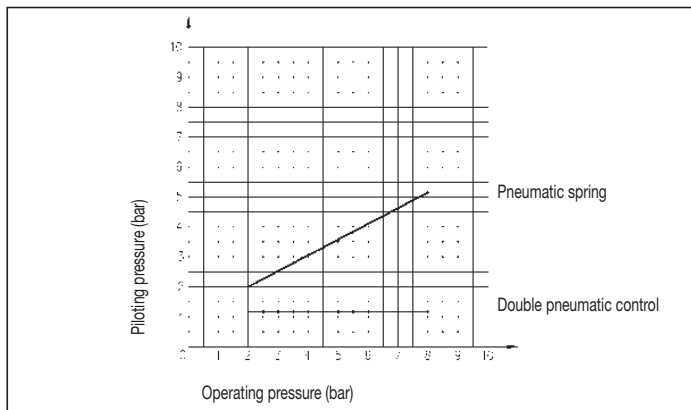

FLOW CHART - MEV/18

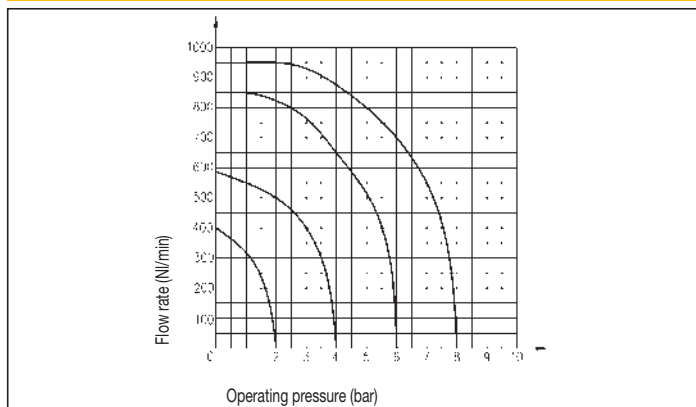

PILOT ACTUATED VALVES G 1/8 - MEV 8

Symbol	Function	Controls		Response time at 6 bar (ms)		Flow rate at 6 bar $\Delta P = 1$ bar (Nl/min)	Weight (g)	TYPE
		Pilot	Return	Energized	De-energized			
	5/2 monostable	Solenoid	Mechanical spring	10	10	650	100	MEV8 KR/ZR
		Solenoid	Pneumatic spring	12	20			MEV8 KR/TQ
	5/2 bistable	Solenoid	Pneumatic spring	10	10	650	100	MEV8 KR/KR
	5/3 closed center	Solenoid	Mechanical spring	10	10	510	100	MEV8 SR/SR
	5/3 open center	Solenoid	Mechanical spring	10	10	510	100	MEV8 AR/AR
	5/3 pressure center	Solenoid	Mechanical spring	10	10	650	100	MEV8 PR/PR

5 PORT - MONOSTABLE

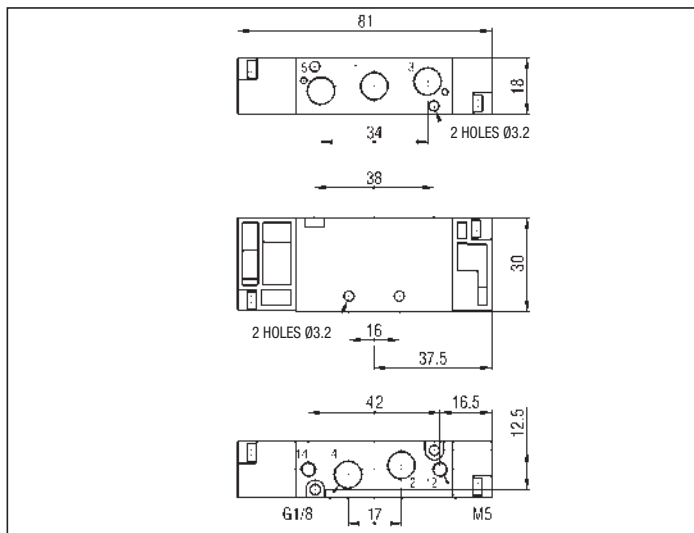

5 PORT - BISTABLE

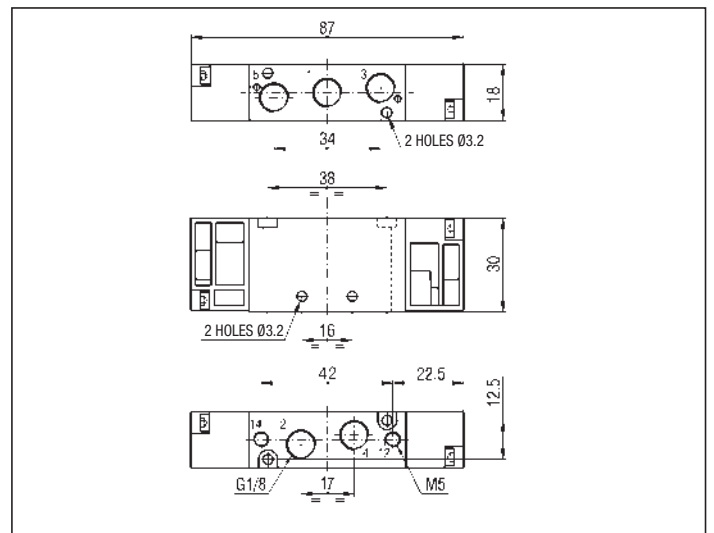

5 PORT - 3 POSITIONS

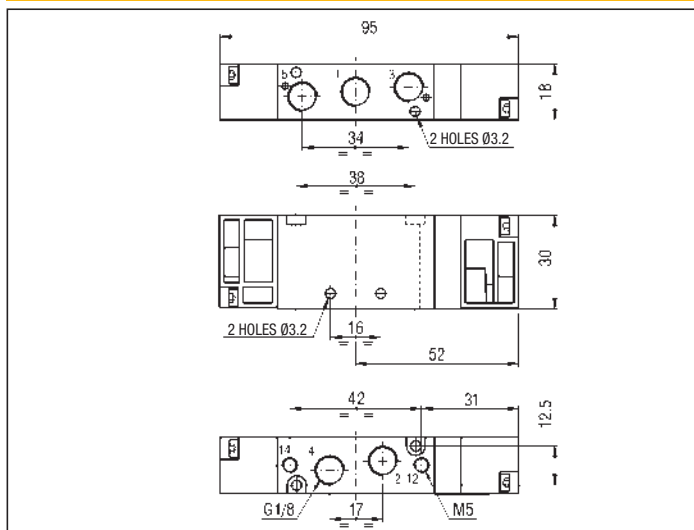

2

SOLENOID ACTUATED VALVES G 1/8 - MEV 8

Symbol	Function	Controls		Response time at 6 bar (ms)		Flow rate at 6 bar $\Delta P = 1$ bar (l/min)	Weight (g)	TYPE*
		Pilot	Return	Energized	De-energized			
	5/2 monostable	Solenoid	Mechanical spring	10	30	650	130	MEV8 KUC/ZR
		Solenoid	Pneumatic spring	10	20			MEV8 KUC/TQ
		Solenoid pilot assisted	Mechanical spring	10	30			MEV8 KUR/ZR
	5/2 bistable	Solenoid	Solenoid	10	10	650	160	MEV8 KUC/KUC
		Solenoid pilot assisted	Solenoid pilot assisted					MEV8 KUR/KUR
	5/3 closed centre	Solenoid	Mechanical spring	10	25	510	160	MEV8 SUC/SUC
		Solenoid pilot assisted	Mechanical spring					MEV8 SUR/SUR
	5/3 open centre	Solenoid	Mechanical spring	10	25	510	160	MEV8 AUC/AUC
		Solenoid pilot assisted	Mechanical spring					MEV8 AUR/AUR
	5/3 pressure centre	Solenoid	Mechanical spring	10	25	650	160	MEV8 PUC/PUC
		Solenoid pilot assisted	Mechanical spring					MEV8 PUR/PUR

* SPECIFY THE VOLTAGE IN THE ORDER - E.G.: MEV8 KUC/ZR 02400
 TYPES OF THE SOLENOID VALVES INCLUDE THE PILOTING SOLENOID VALVES "UMCSV" - SEE ON PAGE 2.3)

02400 = 24 V DC
 02450-60 = 24 V AC

11050-60 = 110 V AC
 22050-60 = 220 V AC

5 PORT - MONOSTABLE

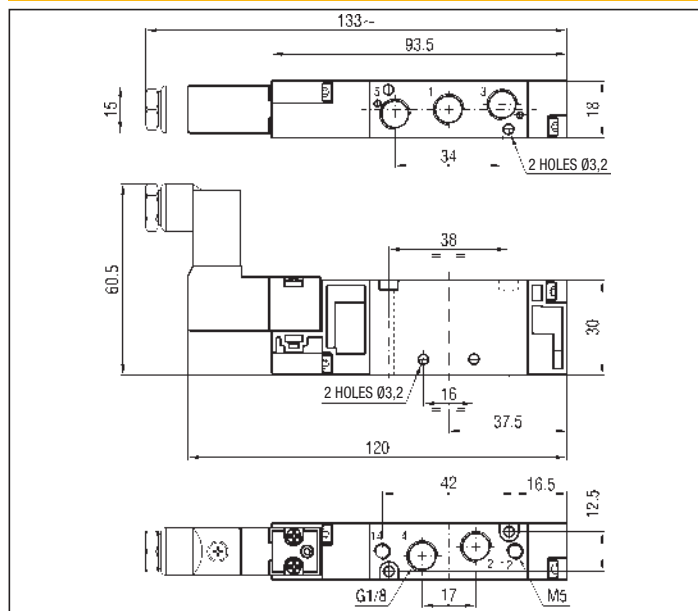

5 PORT - BISTABLE

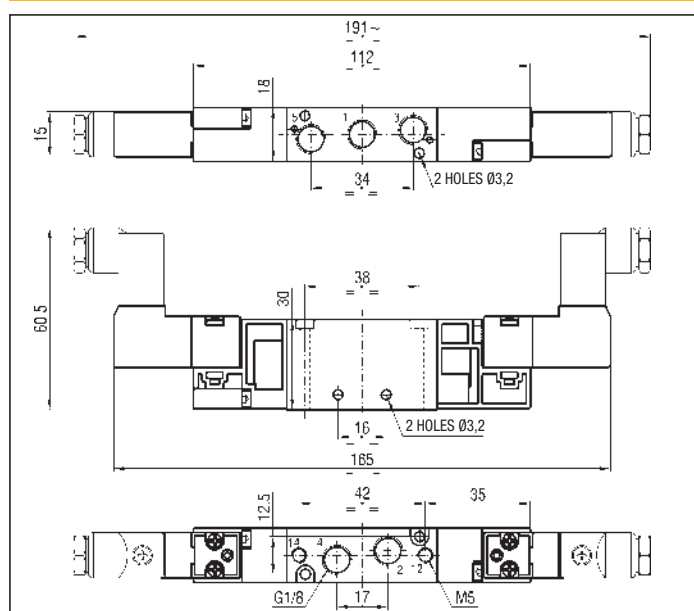

5 PORT - 3 POSITIONS

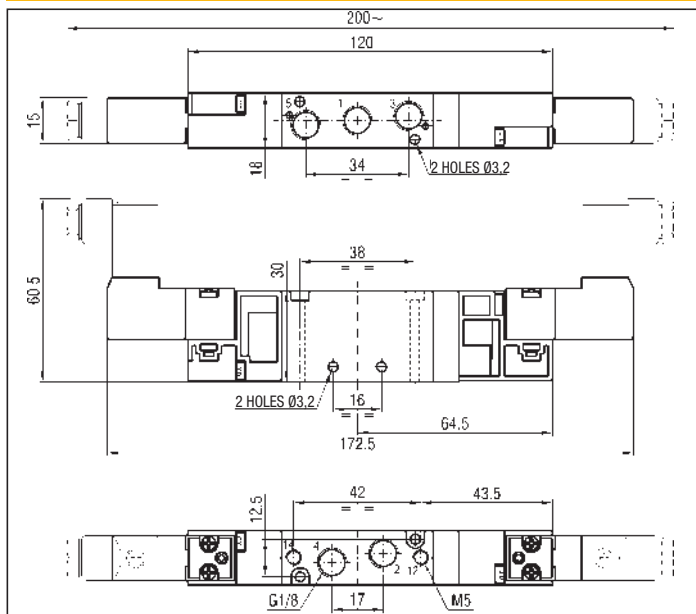

SOLENOID ACTUATED VALVES WITH COILS TOWARD THE BOTTOM G 1/8 - MEVX 8
SUITABLE FOR SINGLE USE OR MULTI-PIN PLUG CONNECTOR

Symbol	Function	Controls		Response time at 6 bar (ms)		Flow rate at 6 bar $\Delta P = 1$ bar (NI/min)	Weight (g)	TYPE*
		Pilot	Return	Energized	De-energized			
	5/2 monostable	Solenoid	Mechanical spring	10	30	650	130	MEVX8 KUC/ZR
		Solenoid	Pneumatic spring	10	20			MEVX8 KUC/TQ
		Solenoid pilot assisted	Mechanical spring	10	30			MEVX8 KUR/ZR
	5/2 bistable	Solenoid	Solenoid	10	10	650	175	MEVX8 KUC/KUC
		Solenoid pilot assisted	Solenoid pilot assisted					MEVX8 KUR/KUR
	5/3 closed centre	Solenoid	Mechanical spring	10	25	510	175	MEVX8 SUC/SUC
		Solenoid pilot assisted	Mechanical spring					MEVX8 SUR/SUR
	5/3 open centre	Solenoid	Mechanical spring	10	25	510	175	MEVX8 AUC/AUC
		Solenoid pilot assisted	Mechanical spring					MEVX8 AUR/AUR
	5/3 pressure centre	Solenoid	Mechanical spring	10	25	650	175	MEVX8 PUC/PUC
		Solenoid pilot assisted	Mechanical spring					MEVX8 PUR/PUR

* SPECIFY THE VOLTAGE IN THE ORDER - E.G.: MEVX8 KUC/ZR 02400
(TYPES OF THE SOLENOID VALVES INCLUDE THE PILOTING SOLENOID VALVES "UMCSV" - SEE ON PAGE 2.3)

02400 = 24 V DC
02450-60 = 24 V AC

5 PORT - MONOSTABLE

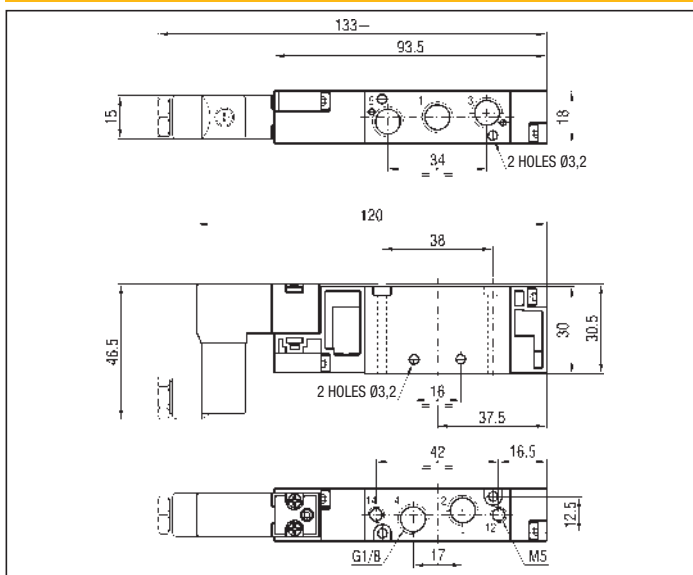

5 PORT - BISTABLE AND 5 PORT - 3 POSITIONS

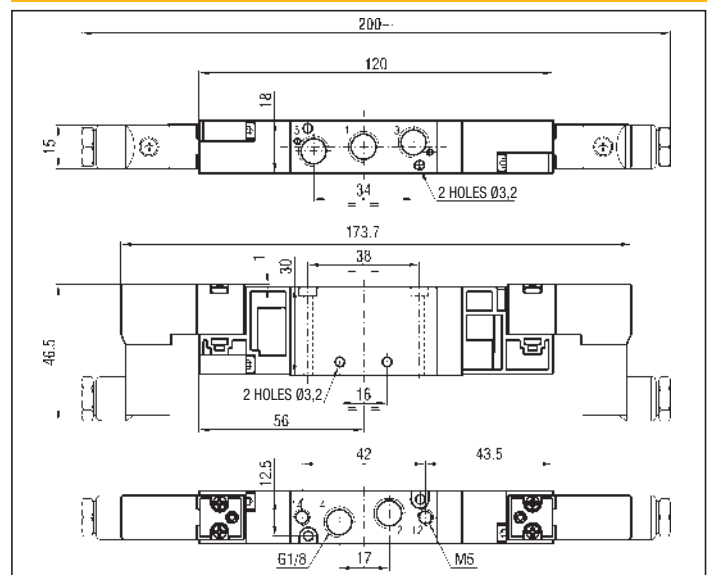

BASE FOR MANIFOLD MOUNTING OF VALVES G 1/8 - KB/MEV8 - Fit for mounting onto DIN 46277/3 rail

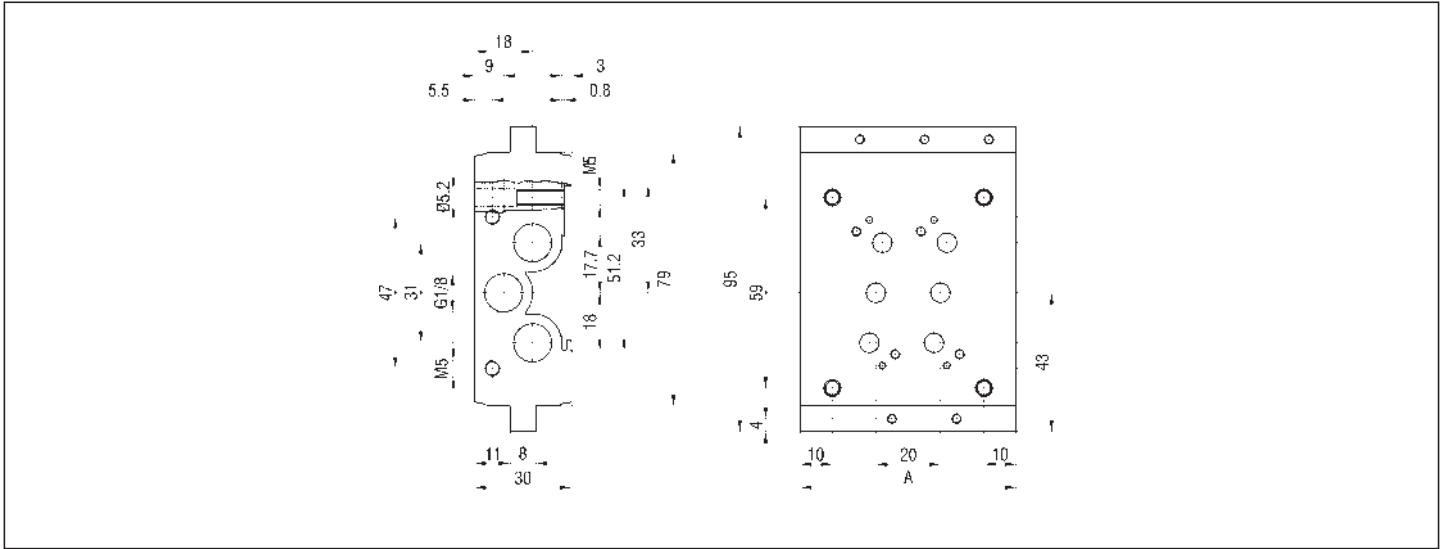

No. of stations	2	3	4	5	6	8	10	12	14	16	18	20
A	67	87	107	127	147	187	227	267	307	347	387	427
Weight (g)	324	421	518	615	712	905	1098	1292	1486	1680	1873	2067
TYPE*	KB/MEV8/2	KB/MEV8/3	KB/MEV8/4	KB/MEV8/5	KB/MEV8/6	KB/MEV8/8	KB/MEV8/10	KB/MEV8/12	KB/MEV8/14	KB/MEV8/16	KB/MEV8/18	KB/MEV8/20

* BASES ARE SUPPLIED COMPLETE WITH SCREWS AND SEALS

BLANKING PLATE - MEV8/PC

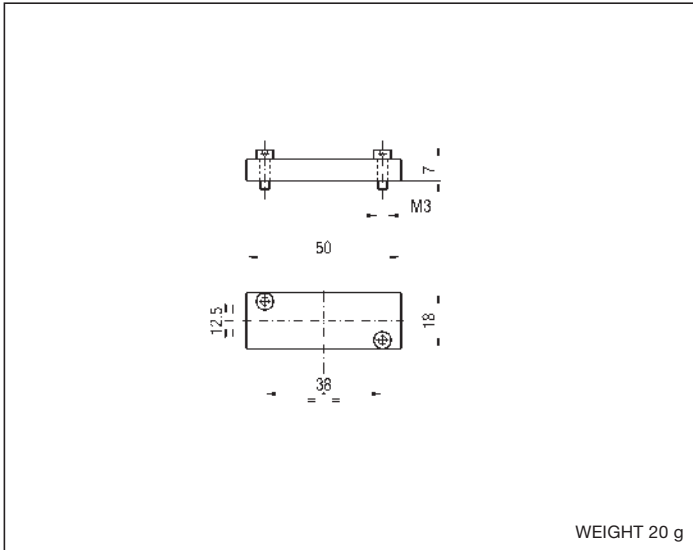

BLANKING PLATE IS SUPPLIED COMPLETE WITH SCREWS AND SEALS

FIXING PLATE FOR DIN 46277/3 RAIL - MEV8/PF

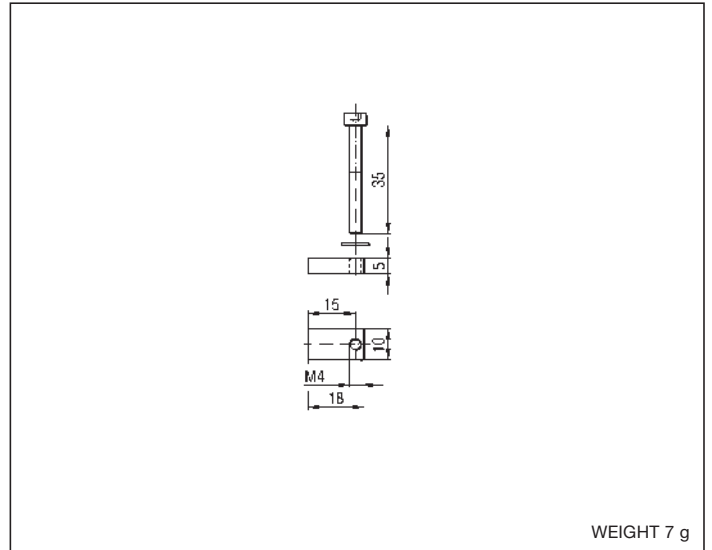

FIXING PLATE IS SUPPLIED COMPLETE WITH SCREWS

2

PILOT ACTUATED VALVES TO VDMA 24563 STANDARD SIZE 02 - MEV 18

Symbol	Function	Controls		Response time at 6 bar (ms)		Flow rate at 6 bar $\Delta P = 1$ bar (Nl/min)	Weight (g)	TYPE
		Pilot	Return	Energized	De-energized			
	5/2 monostable	Pneumatic	Mechanical spring	12	50	510	100	MEV18 KR/ZR
		Pneumatic	Mechanical spring	20	35			MEV18 KR/TQ
	5/2 bistable	Pneumatic	Pneumatic	12	12	510	100	MEV18 KR/KR
	5/3 closed centre	Pneumatic	Mechanical spring	15	15	420	100	MEV18 SR/SR
	5/3 open centre	Pneumatic	Mechanical spring	15	15	420	100	MEV18 AR/AR
	5/3 pressure centre	Pneumatic	Mechanical spring	15	15	500	100	MEV18 PR/PR

5 PORT - MONOSTABLE

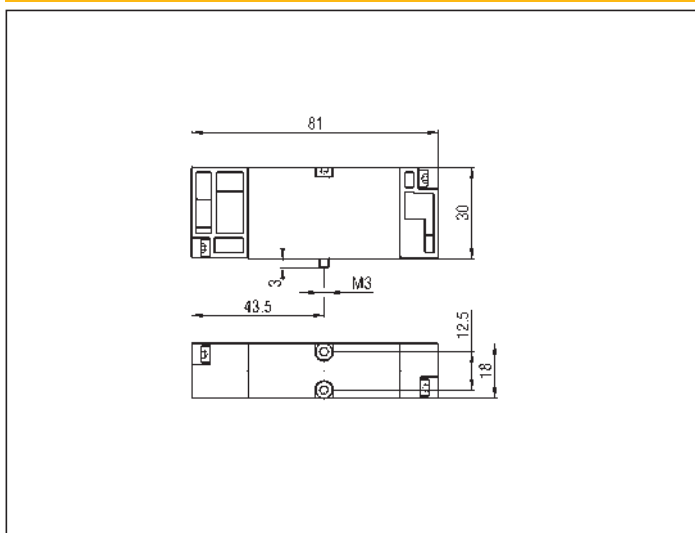

5 PORT - BISTABLE

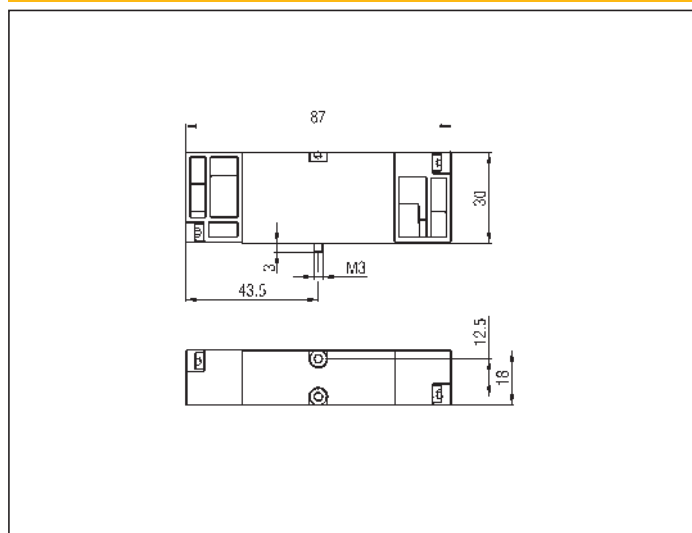

5 PORT - 3 POSITIONS

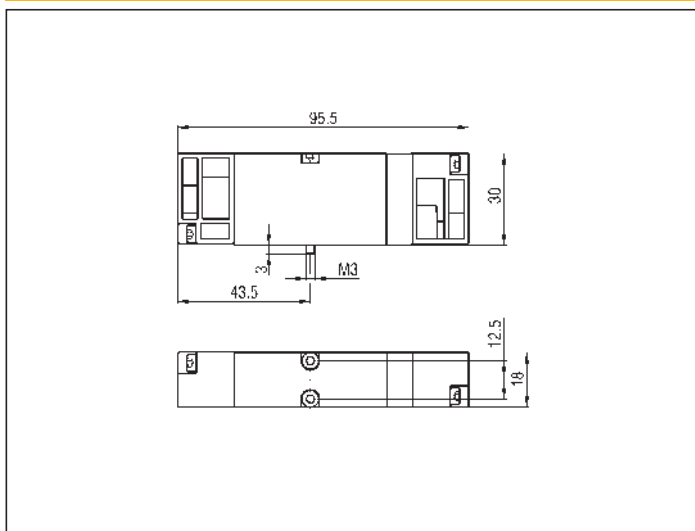

SOLENOID ACTUATED VALVES TO VDMA 24563 STANDARD SIZE 02 - MEV 18

Symbol	Function	Controls		Response time at 6 bar (ms)		Flow rate at 6 bar $\Delta P = 1 \text{ bar (Nl/min)}$	Weight (g)	TYPE*
		Pilot	Return	Energized	De-energized			
	5/2 monostable	Solenoid	Mechanical spring	10	50	510	130	MEV18 KUC/ZR
		Solenoid	Pneumatic spring	12	35			MEV18 KUC/TQ
		Solenoid pilot assisted	Mechanical spring	10	50			MEV18 KUR/ZR
	5/2 bistable	Solenoid	Solenoid	10	10	510	160	MEV18 KUC/KUC
		Solenoid pilot assisted	Solenoid pilot assisted					MEV18 KUR/KUR
	5/3 closed centre	Solenoid	Mechanical spring	10	30	420	160	MEV18 SUC/SUC
		Solenoid pilot assisted	Mechanical spring					MEV18 SUR/SUR
	5/3 open centre	Solenoid	Mechanical spring	10	30	420	160	MEV18 AUC/AUC
		Solenoid pilot assisted	Mechanical spring					MEV18 AUR/AUR
	5/3 pressure centre	Solenoid	Mechanical spring	10	30	500	160	MEV18 PUC/PUC
		Solenoid pilot assisted	Mechanical spring					MEV18 PUR/PUR

* SPECIFY THE VOLTAGE IN THE ORDER - E.G.: MEV18 KUC/ZR 02400
 (TYPES OF THE SOLENOID VALVES INCLUDE THE PILOTING SOLENOID VALVES "UMCSV" - SEE ON PAGE 2.3)

02400 = 24 V DC
 02450-60 = 24 V AC

11050-60 = 110 V AC
 22050-60 = 220 V AC

5 PORT - MONOSTABLE

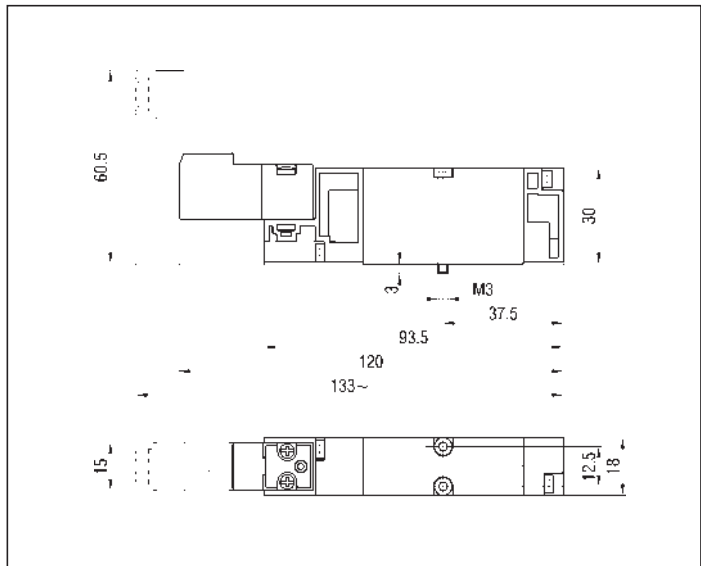

5 PORT - BISTABLE

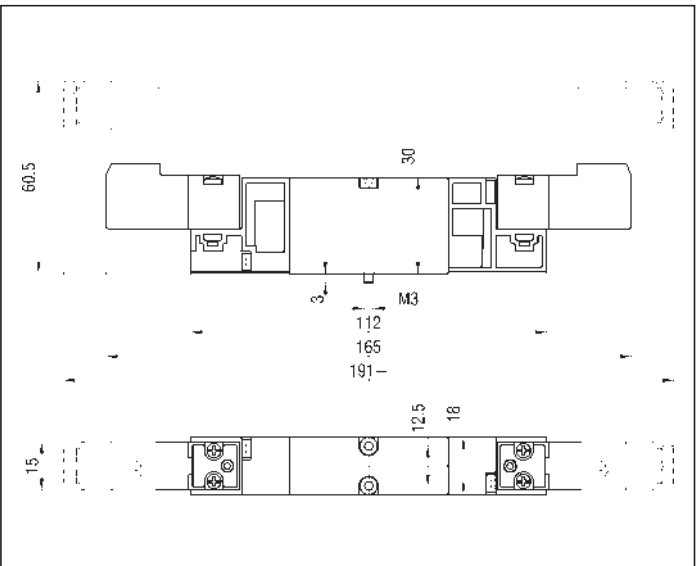

5 PORT - 3 POSITION

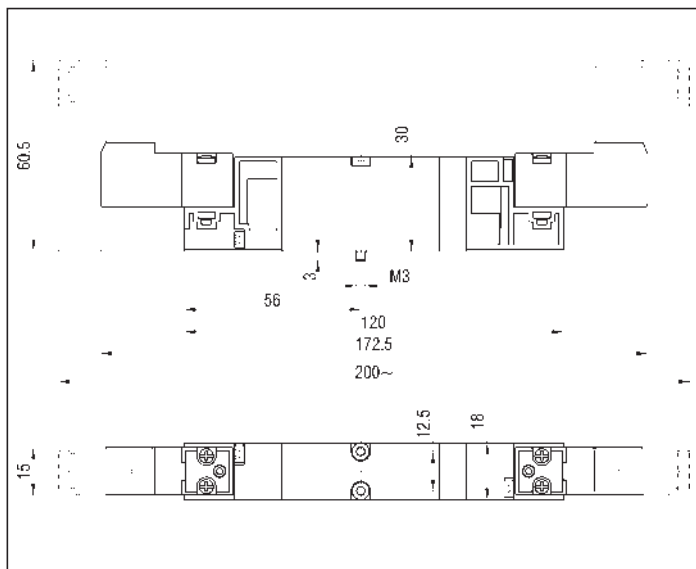

SOLENOID ACTUATED VALVES WITH COILS TOWARD THE BOTTOM TO VDMA 24563 STANDARD SIZE 02 - MEVX 18
SUITABLE FOR SINGLE USE OR MULTI-PIN PLUG CONNECTOR

Symbol	Function	Controls		Response time at 6 bar (ms)		Flow rate at 6 bar $\Delta P = 1 \text{ bar (Nl/min)}$	Weight (g)	TYPE*
		Pilot	Return	Energized	De-energized			
	5/2 monostable	Solenoid	Mechanical spring	10	50	510	130	MEVX18 KUC/ZR
		Solenoid	Pneumatic spring	12	35			MEVX18 KUC/TQ
		Solenoid pilot assisted	Mechanical spring	10	50			MEVX18 KUR/ZR
	5/2 bistable	Solenoid	Solenoid	10	10	510	175	MEVX18 KUC/KUC
		Solenoid pilot assisted	Solenoid pilot assisted					MEVX18 KUR/KUR
	5/3 closed centre	Solenoid	Mechanical spring	10	30	420	175	MEVX18 SUC/SUC
		Solenoid pilot assisted	Mechanical spring					MEVX18 SUR/SUR
	5/3 open centre	Solenoid	Mechanical spring	10	30	420	175	MEVX18 AUC/AUC
		Solenoid pilot assisted	Mechanical spring					MEVX18 AUR/AUR
	5/3 pressure centre	Solenoid	Mechanical spring	10	30	500	175	MEVX18 PUC/PUC
		Solenoid pilot assisted	Mechanical spring					MEVX18 PUR/PUR

2

* SPECIFY THE VOLTAGE IN THE ORDER - E.G.: MEVX18 KUC/ZR 02400
(TYPES OF THE SOLENOID VALVES INCLUDE THE PILOTING SOLENOID VALVES "UMCSV" - SEE ON PAGE 2.3)

02400 = 24 V DC
02450-60 = 24 V AC

5 PORT - MONOSTABLE 5 PORT - BISTABLE AND 5 PORT - 3 POSITIONS

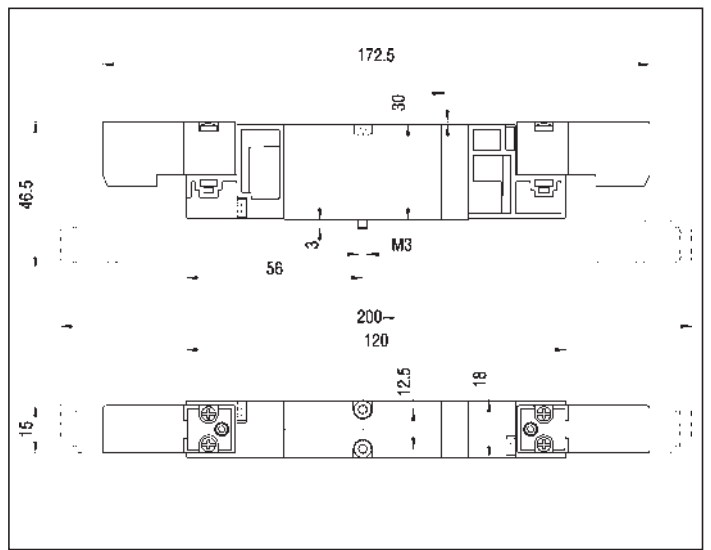
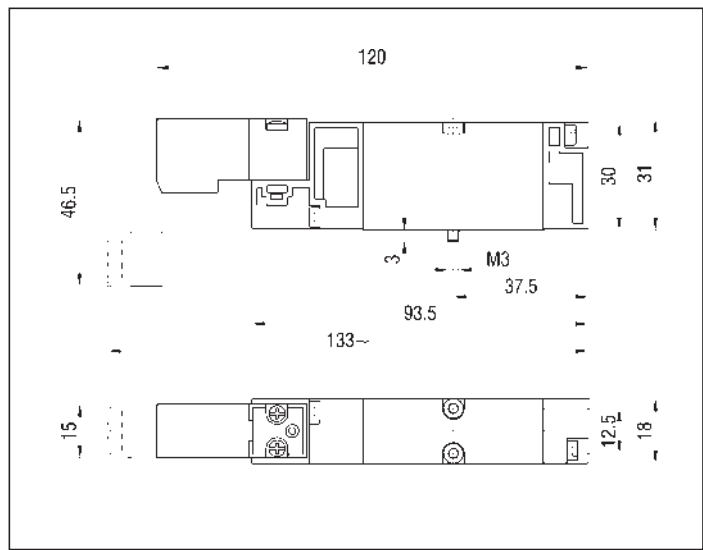

INPUT PLATES (pair) - MEV18PE

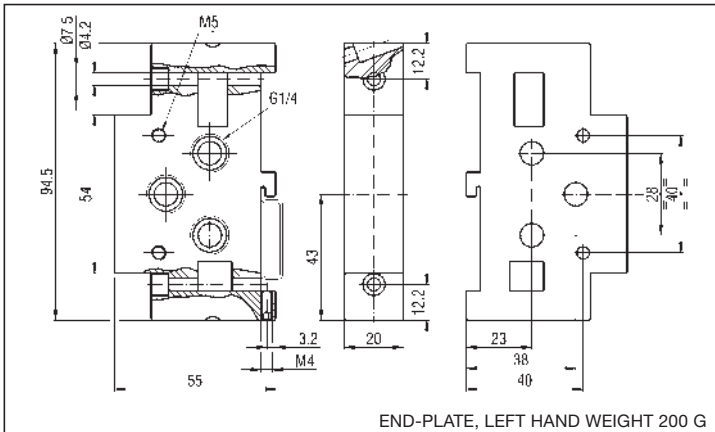

END-PLATE, LEFT HAND WEIGHT 200 G

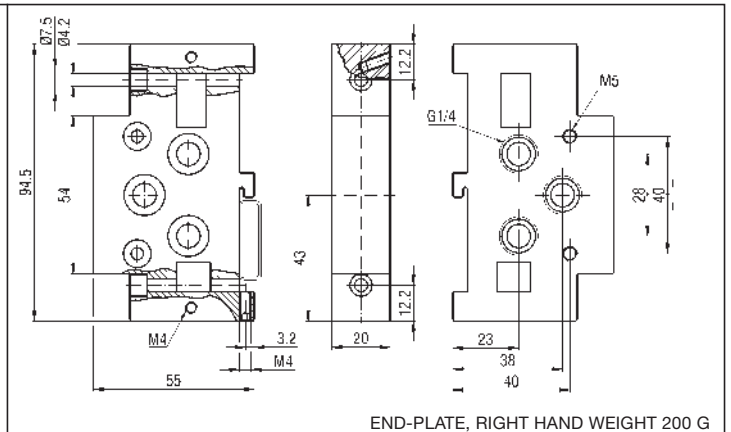

END-PLATE, RIGHT HAND WEIGHT 200 G

INPUT PLATES ARE SUPPLIED COMPLETE WITH SCREWS AND SEALS

MANIFOLD BASE, SIDE PORTED - MEV18BM

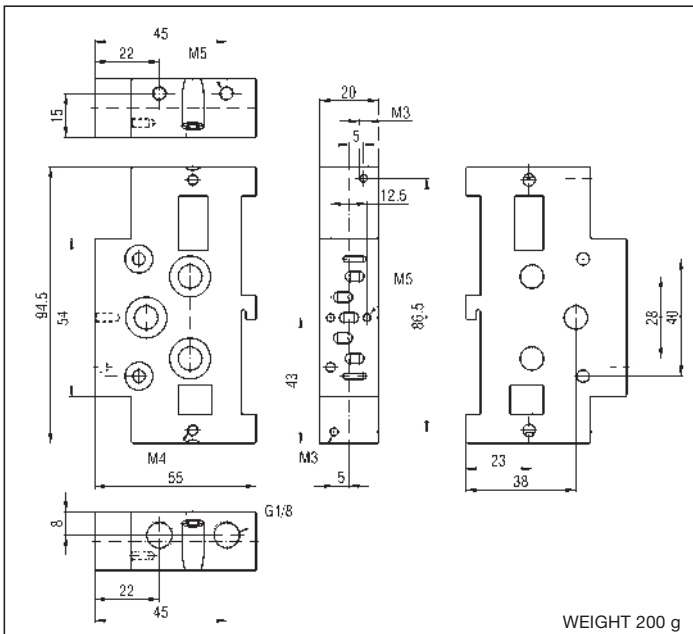

WEIGHT 200 g

MANIFOLD BASE IS SUPPLIED COMPLETE WITH SCREWS AND SEALS

INTERMEDIATE PLATE, TOP PORTED - MEV18PUS

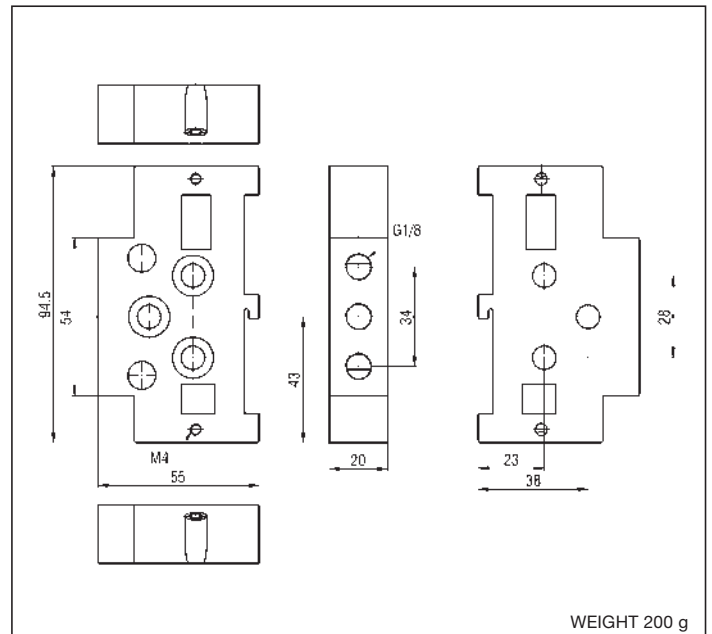

WEIGHT 200 g

INTERMEDIATE PLATE IS SUPPLIED COMPLETE WITH SCREWS AND SEALS

SINGLE BASE SIDE PORTED - MEV18S BS

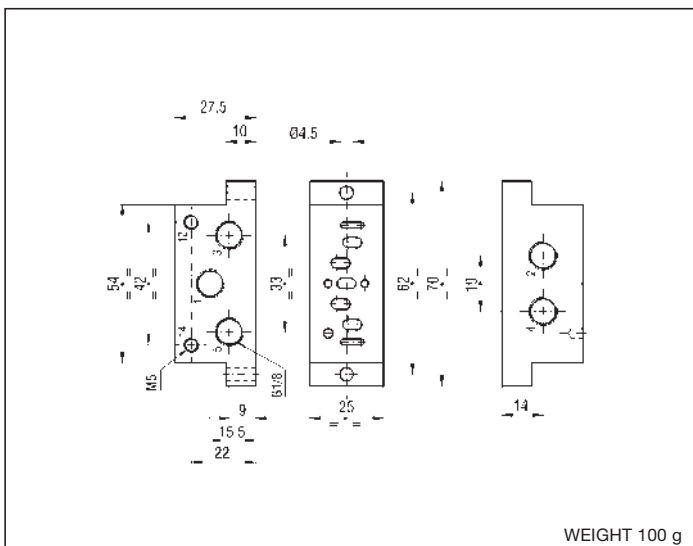

WEIGHT 100 g

BLANKING PLATE - MEV18PC

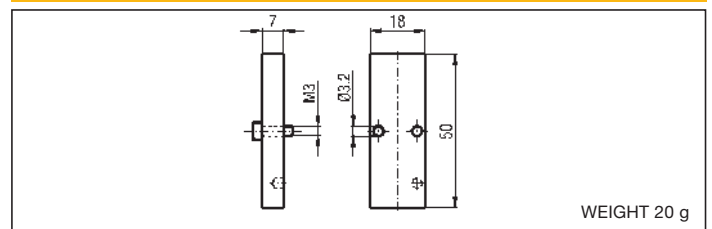

WEIGHT 20 g

BLANKING PLATE IS SUPPLIED COMPLETE WITH SCREWS AND SEALS

DIAPHRAGM - MEV18DG (No.3 PCS)

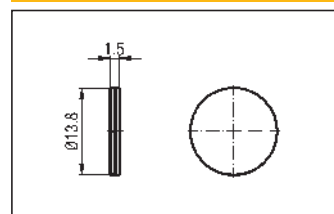

DIAPHRAGM - MEV18DP (No.2 PCS)

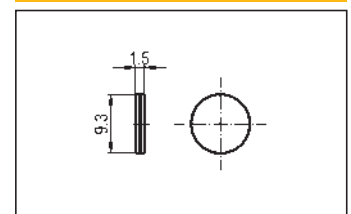

EXAMPLE OF ASSEMBLY - MEV 8 - MEVX 8

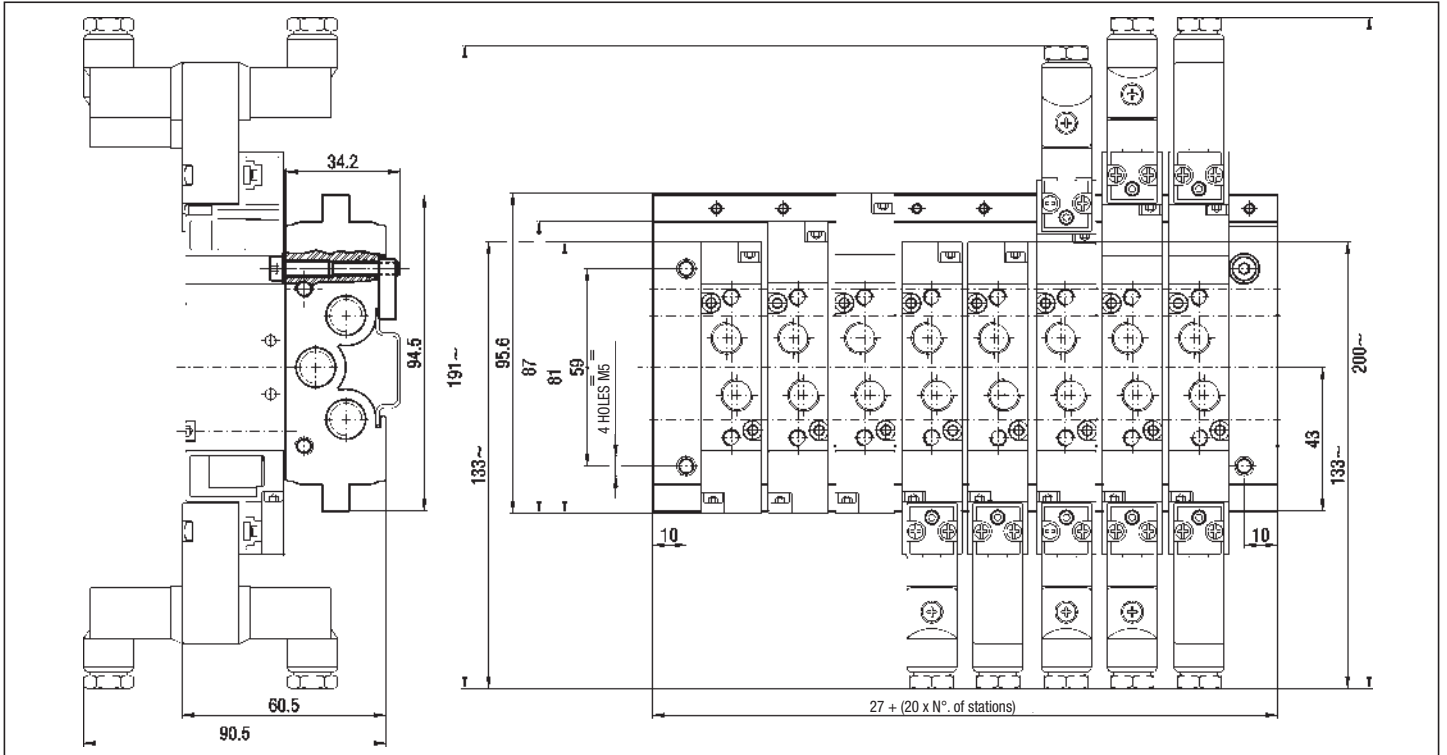

EXAMPLE OF ASSEMBLY - MEV 18 - MEVX 18

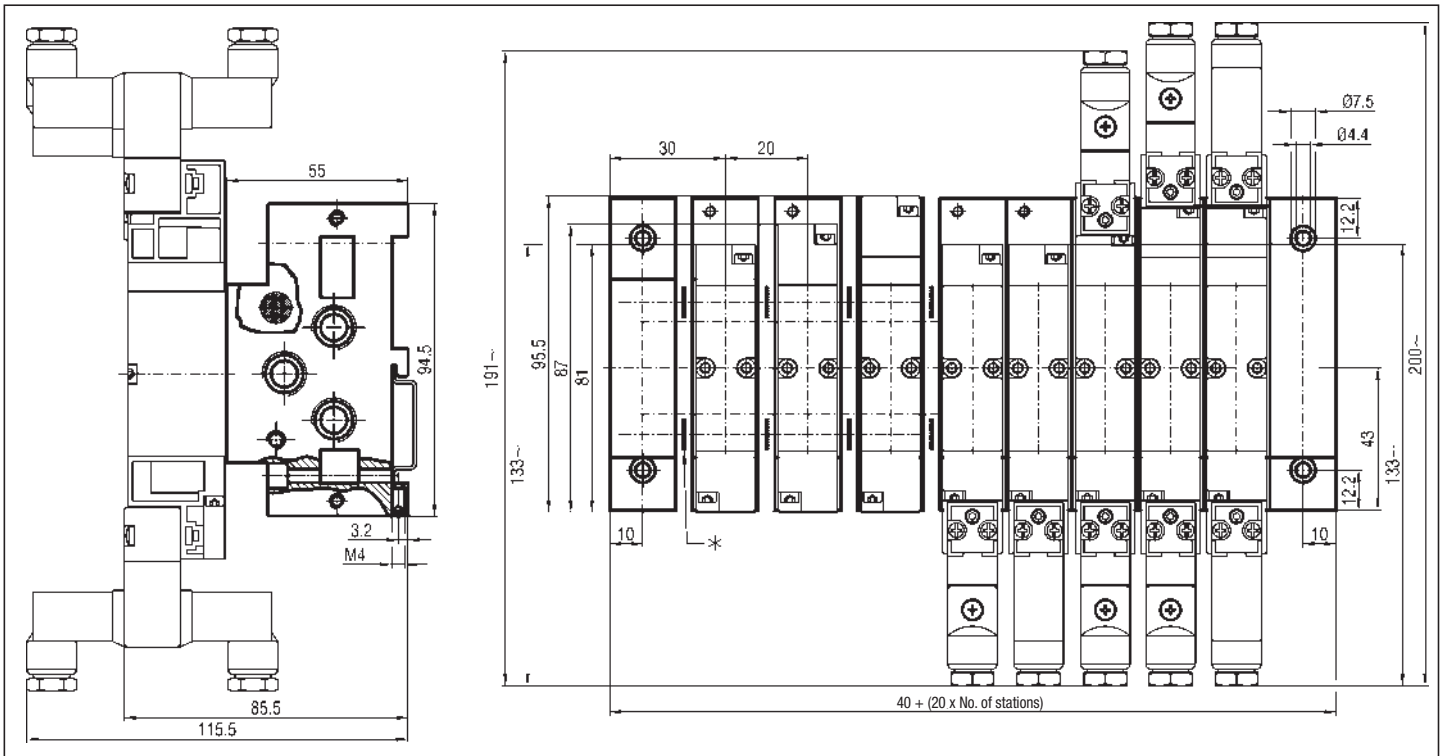

* WITH THE PILOT ACTUATED VALVES USE THE TWO DIAPHRAGMS (TYPE MEV18DP) TO EXCLUDE THE PILOTING EXHAUST (SEE ON PAGE 2.26)

2

25-PIN PLUG, SINGLE - MEV/C1

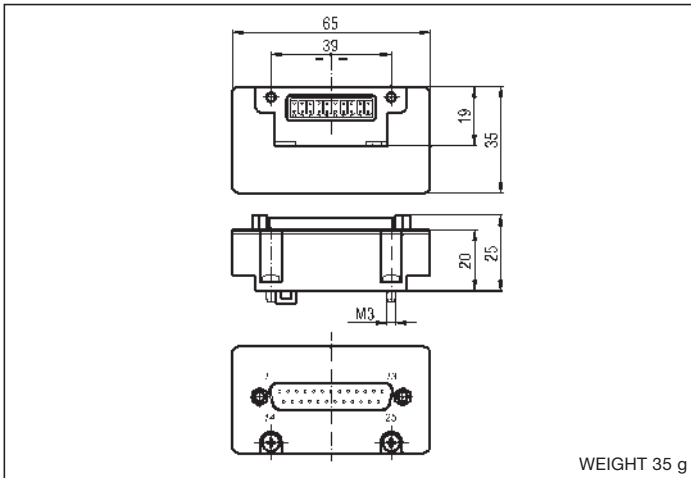

25-PIN PLUG, DOUBLE - MEV/C2

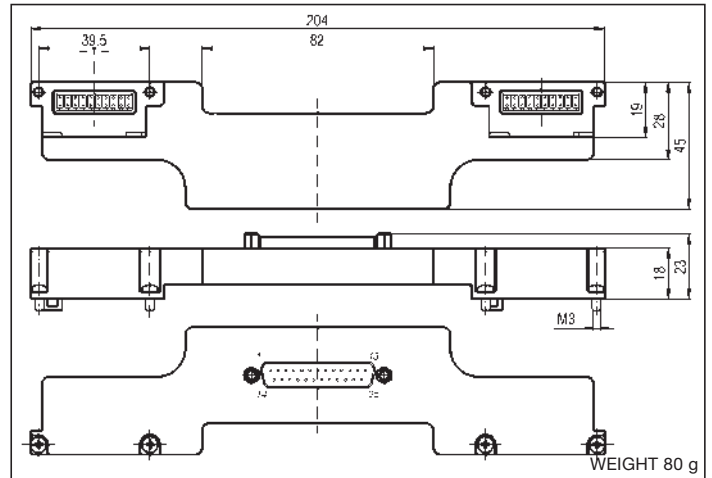

TWO STATIONS MODULE, LEFT - MEV/M2S/AC or DC (24 V)

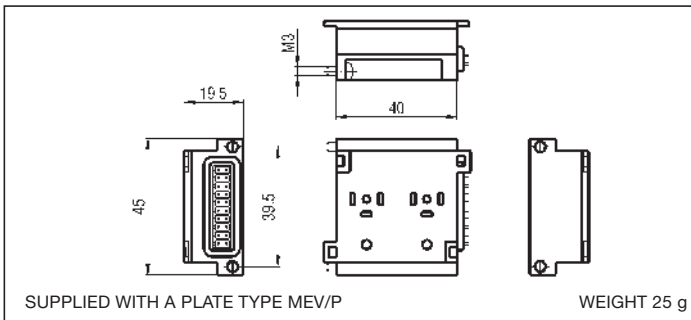

TWO STATIONS MODULE, RIGHT - MEV/M2D/AC or DC

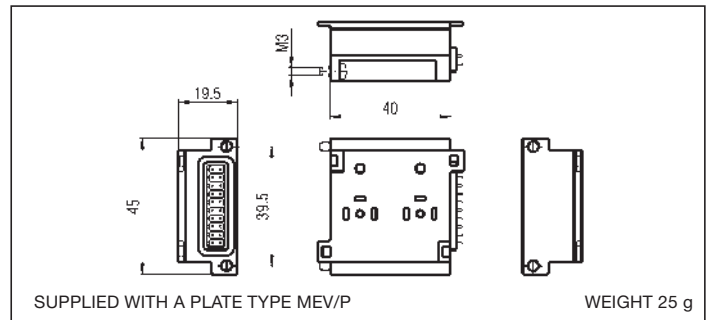

FOUR STATIONS MODULE, LEFT - MEV/M4S/AC or DC (24 V)

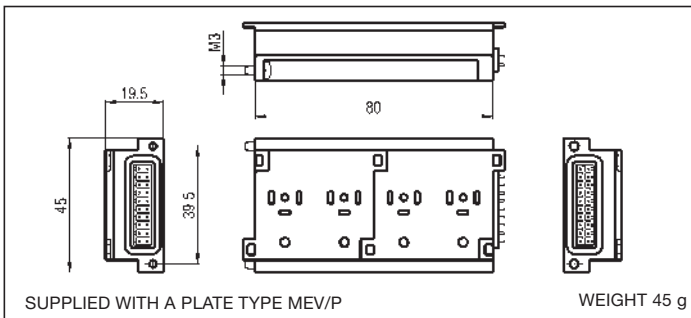

FOUR STATIONS MODULE, RIGHT - MEV/M4D/AC or DC (24 V)

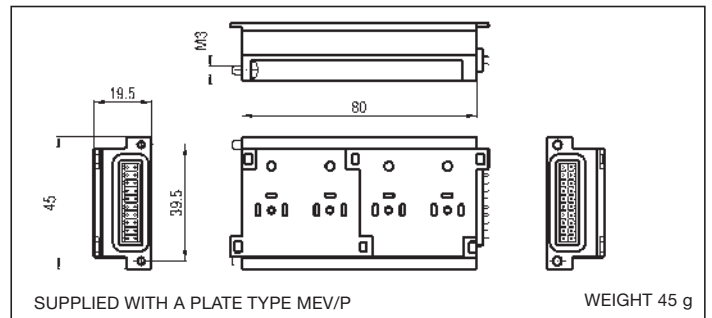

BLANKING CAP - MEV/C

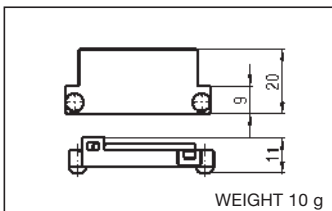

FIXING PLATE - MEV/P

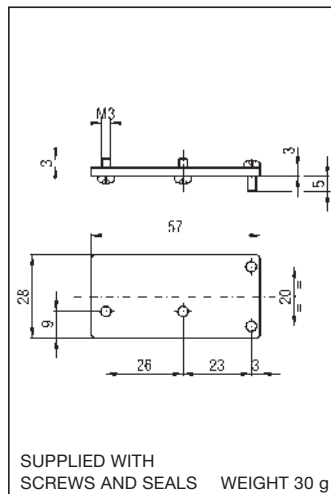

PRE-ASSEMBLED MULTI-PIN CABLE "X" METERS LONG WITH 25-PIN SUB-D PLUG MEV/CF "X" (X= 3, 5, OR 10 m)

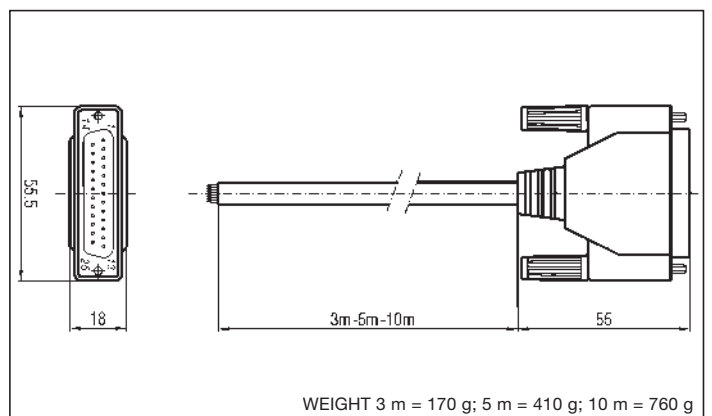

BLANKING PLATE - MEV/PM

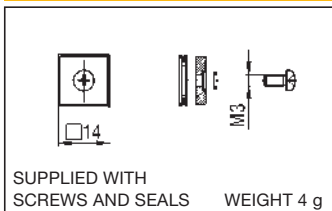

TECHNICAL INFORMATION

CONNECTION WITH ONE DOUBLE 25-PIN SUB-D PLUG, FOR 2 ÷ 11 STATIONS VALVE ISLANDS

Valve	1		2		3		4		5		6		7		8		9		10		11	
Pilot coil	14(sx)	12(dx)	14(sx)	12(dx)	14(sx)	12(dx)	14(sx)	12(dx)	14(sx)	12(dx)	14(sx)	12(dx)	14(sx)	12(dx)	14(sx)	12(dx)	14(sx)	12(dx)	14(sx)	12(dx)	14(sx)	12(dx)
PIN Number	1	12	2	13	3	14	4	15	5	16	6	17	7	18	8	19	9	20	10	21	11	22
Color	brown	green white	red	green chiaro	orange	red black	yellow	orange black	green	yellow black	blue	green black	purple	grey black	grey	black sky blue	white	rose black	black	brown black	rose	orange white

2

Valve	-		-	
Pilot coil	GND*	GND*	GND*	-
PIN Number	23	24	25	-
Color	yellow green	sky blue	grey green	-

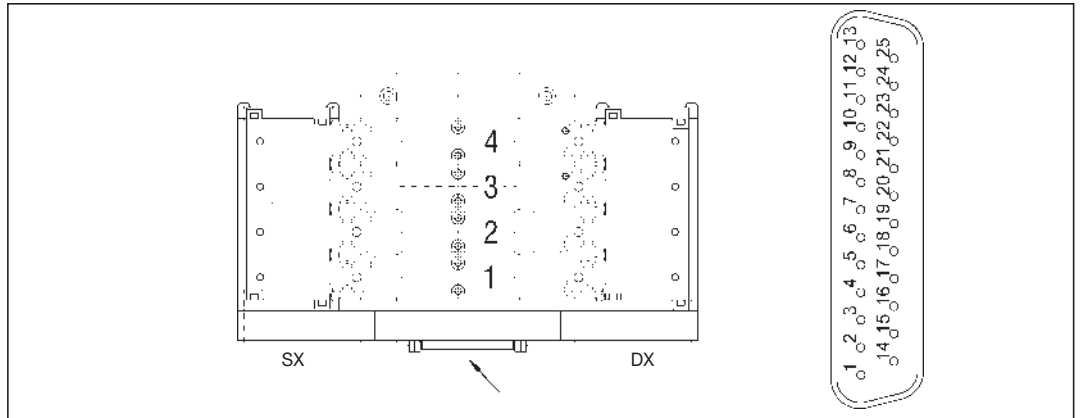

*Common cable

P.S.: For monostable solenoid valves use left modules

CONNECTION WITH TWO SINGLE 25-PIN SUB-D PLUGS, FOR 2 ÷ 16 STATIONS VALVE ISLANDS

Valve	1		2		3		4		5		6		7		8		9		10		11	
Pilot coil	14(sx)	12(dx)	14(sx)	12(dx)	14(sx)	12(dx)	14(sx)	12(dx)	14(sx)	12(dx)	14(sx)	12(dx)	14(sx)	12(dx)	14(sx)	12(dx)	14(sx)	12(dx)	14(sx)	12(dx)	14(sx)	12(dx)
PIN Number	1	1	2	2	3	3	4	4	5	5	6	6	7	7	8	8	9	9	10	10	11	11
Color	brown	brown	red	red	orange	orange	yellow	yellow	green	green	blue	blue	purple	purple	grey	grey	white	white	black	black	red	red

Valve	12		13		14		15		16		-		-		-		-		-	
Pilot coil	14(sx)	12(dx)	14(sx)	12(dx)	14(sx)	12(dx)	14(sx)	12(dx)	14(sx)	12(dx)	GND*	GND*	GND*	GND*	NC	NC	NC	NC	NC	-
PIN Number	12	12	13	13	14	14	15	15	16	16	17	18	19	20	21	22	23	24	25	-
Color	green white	green white	green chiaro	green chiaro	red black	red black	orange black	orange black	yellow black	yellow black	green black	green black	black sky blue	rose black	brown black	orange white	yellow green	sky blue	grey green	-

*Common cable

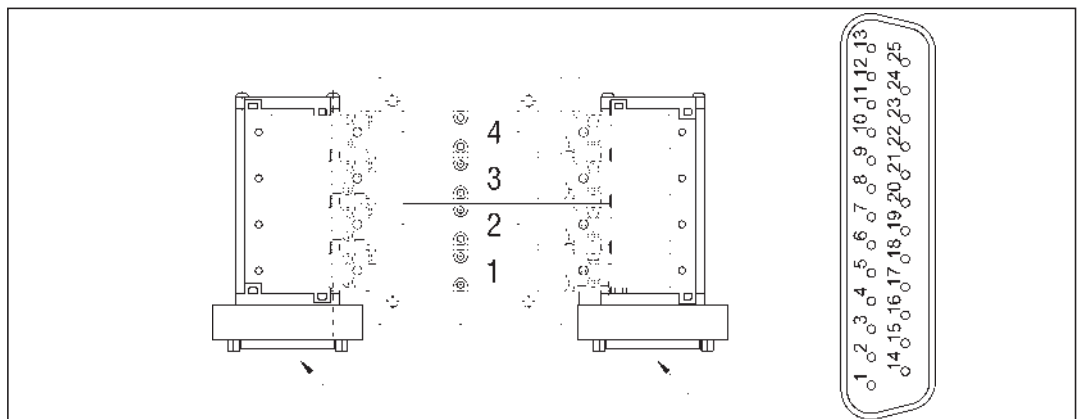

2

MEVX 8 WITH DOUBLE 25-PIN SUB-D PLUG

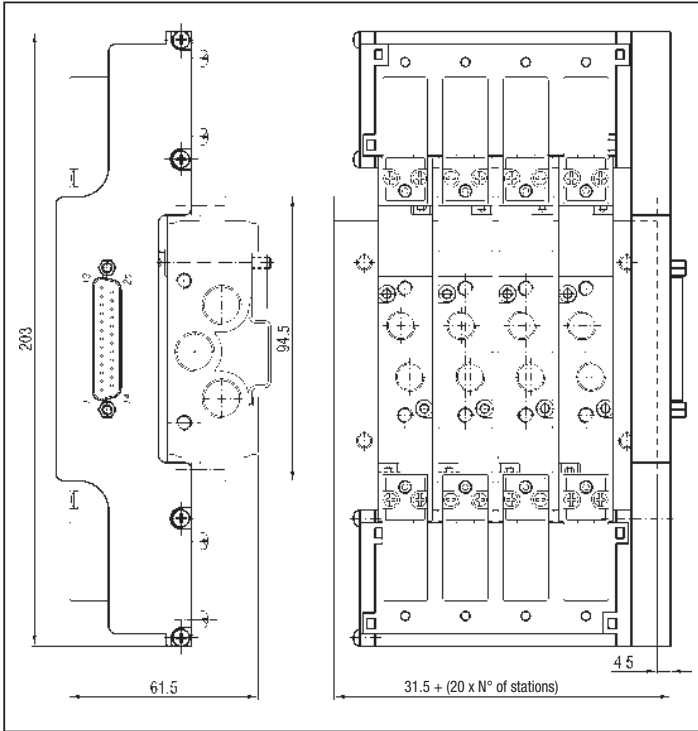

MEVX 8 WITH SINGLE 25-PIN SUB-D PLUG

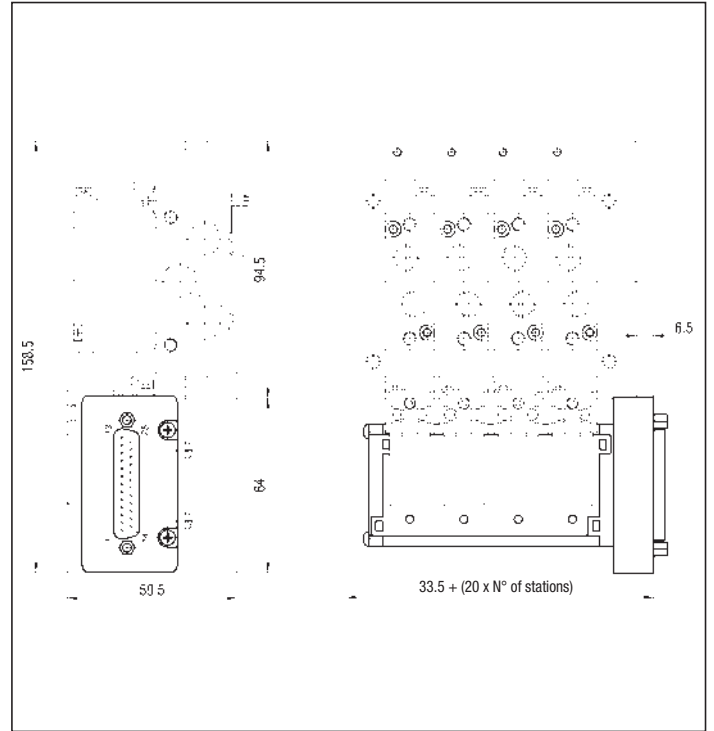

MEVX 18 WITH DOUBLE 25-PIN SUB-D PLUG

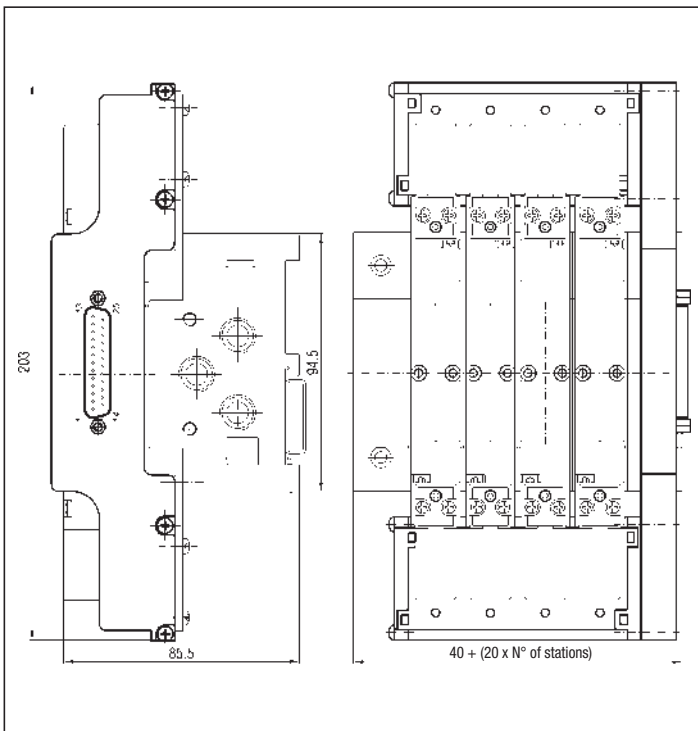

MEVX 18 SINGLE 25-PIN SUB-D PLUG

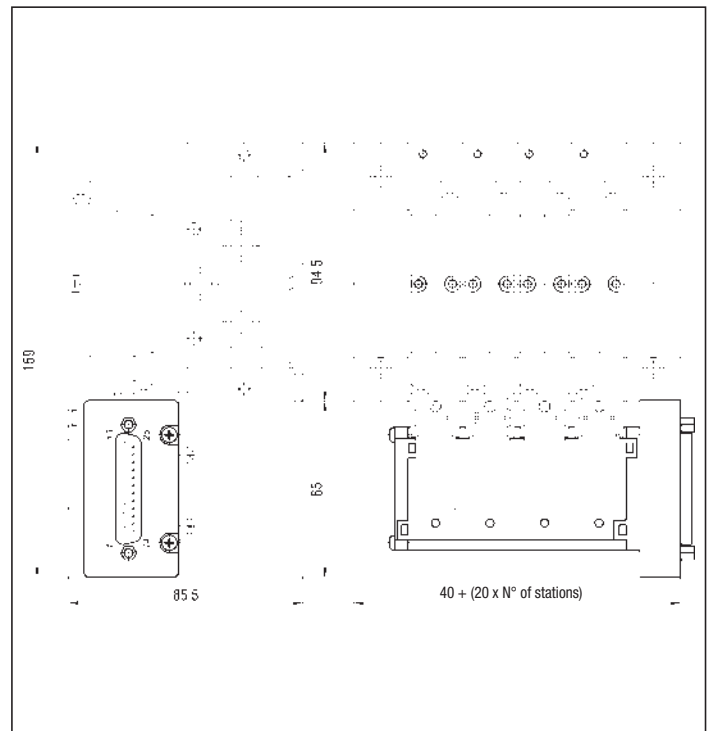

Assembling examples

Multi-pin connection with solenoid valves versions MEVX 8 and MEVX 18

series MEV

2

Solenoid valves versions MEVX allow a multi-pin plug connection with the possibility of creating islands of pre-assembled solenoid valves with a number of positions chosen by the user during the assembling of the components.

The replacement of the solenoid valves can be easily made in every moment.

Connection modules are at 2 or 4 positions that can operate with 24 V AC or DC voltage.

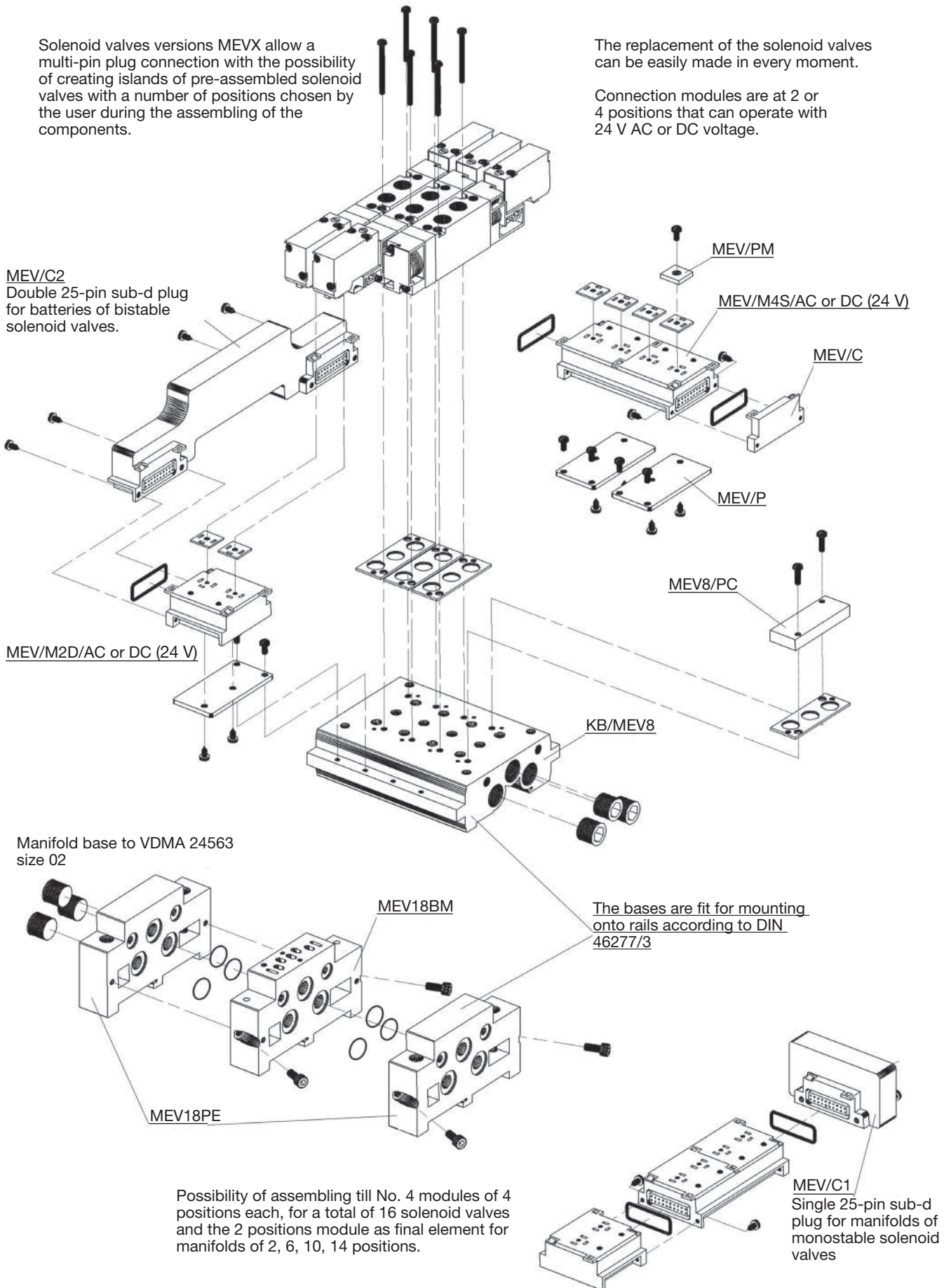

DESCRIPTION

Valves series "MEK", in the 5/2 and 5/3 pneumatic functions, have been realized with compact overall dimensions yet assuring high flow. The kind of construction is based on a balanced spool with dynamic seal thanks to antiglueing mix seals positioned on the same spool. In the solenoid control version, size G 1/8 supports 15 mm low absorption direct acting solenoid valve type UMCSV, while size G 1/4 supports both 15 than 22 mm direct acting solenoid valve type C/USCSV with sleeve \varnothing 9 mm. This series of valves is prearranged for manifold mounting with fixed stations and with conveyed inlet and exhausts, by means of frontal screws. The bases are fit for mounting onto rails according to DIN 46277/3.

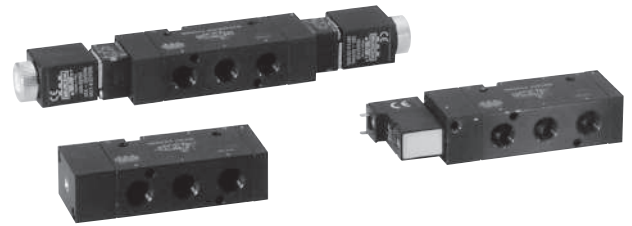

TECHNICAL DATA

Operating pressure	Monostable: 2 ÷ 8 bar Bistable: 1,5 ÷ 8 bar
Working temperature	0 ÷ +60 °C (-10 °C with dry air)
Fluid	Filtered, unlubricated or continuous lubricated compressed air
Port size	G 1/8 - G 1/4
Pneumatic piloting port size	M 5
Nominal diameter	G 1/8 = 5 mm; G 1/4 = 6,5 mm
Piloting solenoid valve	UMCSV for G 1/8 and G 1/4 – see chapter Direct acting solenoid valves on page 2.3; C/USCSV for G 1/4 – see chapter Direct acting solenoid valves on page 2.11
Coil	USB for G 1/4 – see chapter Coils on page 2.14
Electric connectors	MEK192/N for G 1/8 and G1/4 with UMCSV; USR102/N9 for G 1/4 with C/USCSV See chapter Connectors on page 2.15

MATERIALS

Bottoms	Anodized aluminium alloy
Body	Anodized aluminium alloy
Springs	Stainless steel
Seals	NBR rubber
Spool	Anodized aluminium alloy
Piston	Anodized aluminium alloy

SPARE PARTS

Contact the commercial office

FLOW CHART - MEK G 1/8 - 5/2

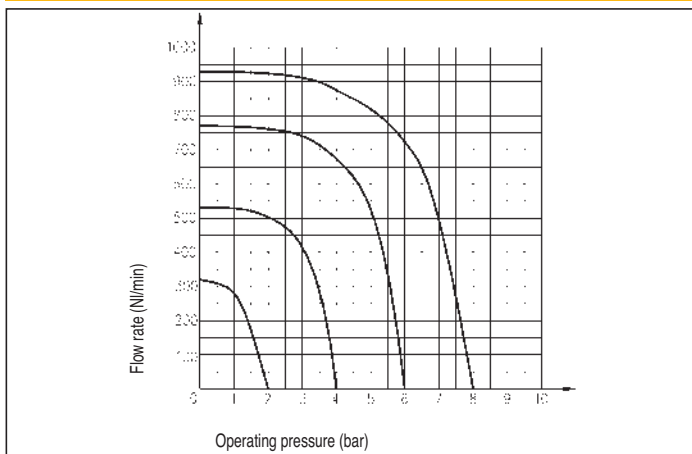

PILOTING CHART - MEK G 1/8

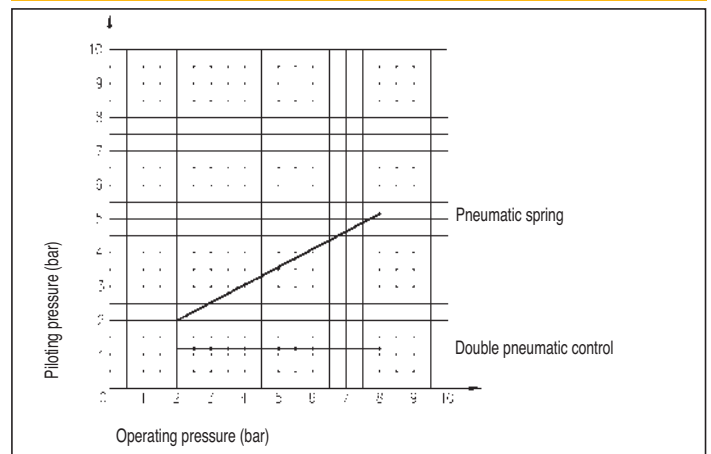

FLOW CHART - MEK G 1/4 - 5/2

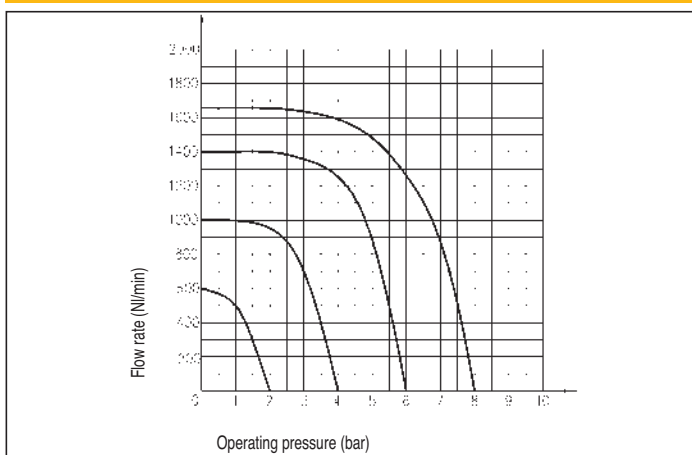

PILOTING CHART - MEK G 1/4

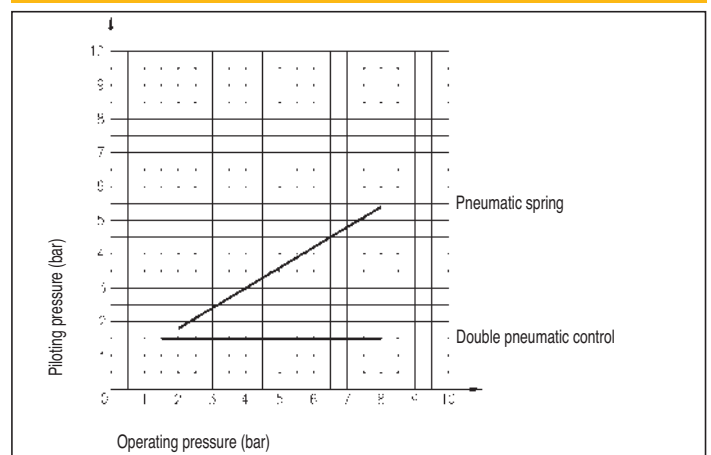

PILOT ACTUATED VALVES G 1/8

Symbol	Function	Controls		Response time at 6 bar (ms)		Flow rate at 6 bar $\Delta P = 1 \text{ bar (Nl/min)}$	Weight (g)	TYPE
		Pilot	Return	Energized	De-energized			
	5/2 monostable	Pneumatic	Mechanical spring	5	10	530	110	MEKCA8 KR/ZQ
		Pneumatic	Mechanical spring	7	5			MEKCA8 KR/TQ
	5/2 bistable	Pneumatic	Pneumatic	3	3	530	120	MEKCA8 KR/KR
	5/3 closed centre	Pneumatic	Mechanical spring	4	8	450	135	MEKCA8 SR/SR
	5/3 open centre	Pneumatic	Mechanical spring	4	8	450	135	MEKCA8 AR/AR
	5/3 pressure centre	Pneumatic	Mechanical spring	4	8	450	135	MEKCA8 PR/PR

MEKCA8 KR/ZQ

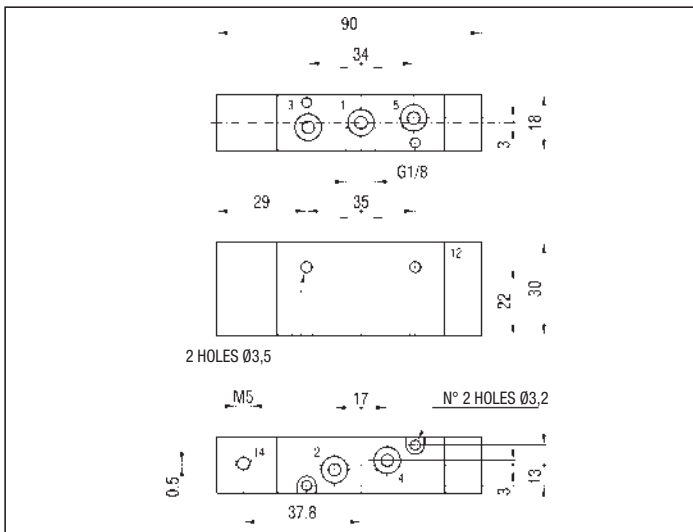

MEKCA8 KR/TQ

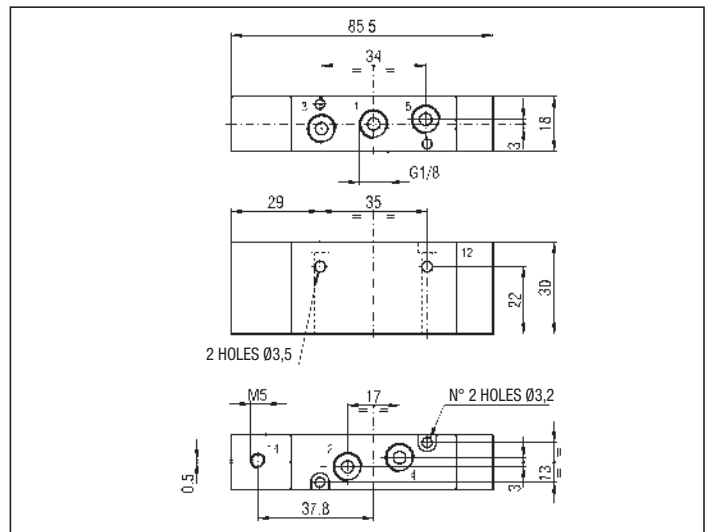

MEKCA8 KR/KR

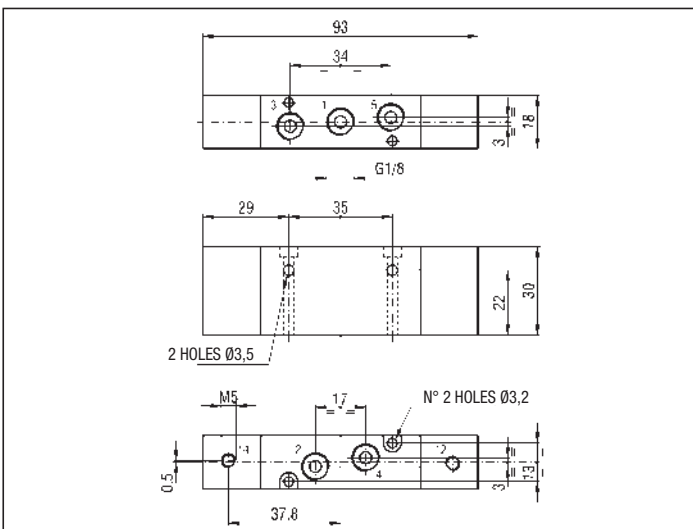

MEKCA8 SR/SR - MEKCA8 AR/AR - MEKCA8 PR/PR

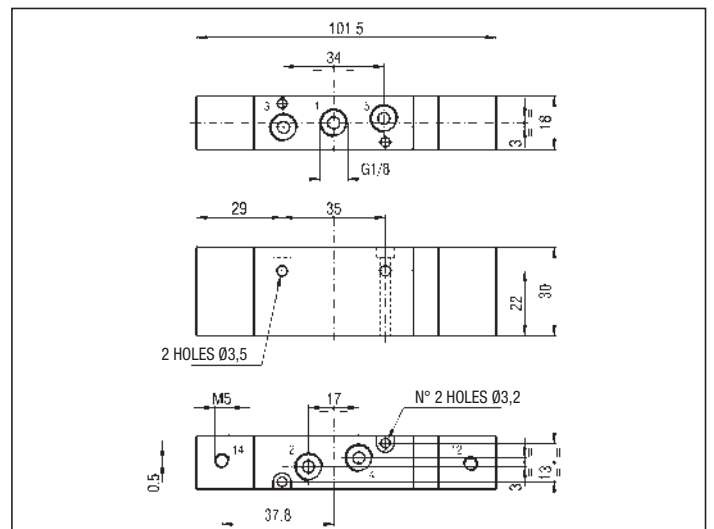

SOLENOID ACTUATED VALVES G 1/8

Symbol	Function	Controls		Response time at 6 bar (ms)		Flow rate at 6 bar $\Delta P = 1$ bar (l/min)	Weight (g)	TYPE*
		Pilot	Return	Energized	De-energized			
	5/2 monostable	Solenoid	Pneumomechanical spring	12	15	530	150	MEKCA8 KUC/ZQ
		Solenoid	Pneumatic spring	12	15			MEKCA8 KUC/TQ
		Solenoid pilot assisted	Mechanical spring	10	20			MEKCA8 KUR/ZQ
	5/2 bistable	Solenoid	Solenoid	9	9	530	195	MEKCA8 KUC/KUC
		Solenoid pilot assisted	Solenoid pilot assisted					MEKCA8 KUR/KUR
	5/3 closed centre	Solenoid	Mechanical spring	10	25	450	210	MEKCA8 SUC/SUC
		Solenoid pilot assisted	Mechanical spring					MEKCA8 SUR/SUR
	5/3 open centre	Solenoid	Mechanical spring	10	25	450	210	MEKCA8 AUC/AUC
		Solenoid pilot assisted	Mechanical spring					MEKCA8 AUR/AUR
	5/3 pressure centre	Solenoid	Mechanical spring	10	25	450	210	MEKCA8 PUC/PUC
		Solenoid pilot assisted	Mechanical spring					MEKCA8 PUR/PUR

* SPECIFY THE VOLTAGE IN THE ORDER - E.G.: MEKCA8 KUC/ZQ 02400
(TYPES OF THE SOLENOID VALVES INCLUDE THE PILOTING SOLENOID VALVES "UMCSV" - SEE ON PAGE 2.3)

02400 = 24 V DC
02450-60 = 24 V AC

11050-60 = 110 V AC
22050-60 = 220 V AC

MEKCA8 KUC/ZQ

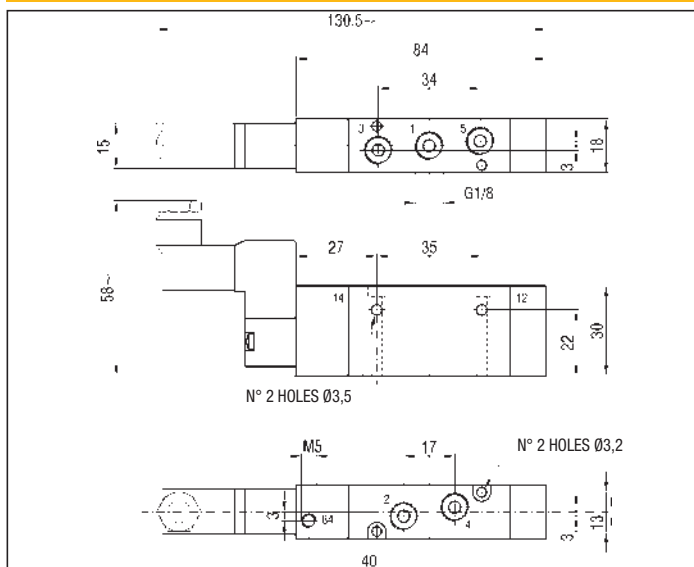

MEKCA8 KUC/TQ

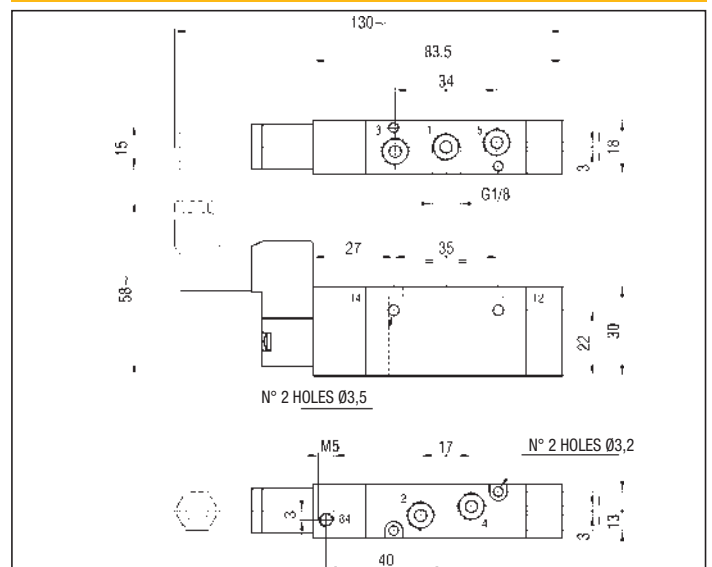

MEKCA8 KUR/ZQ

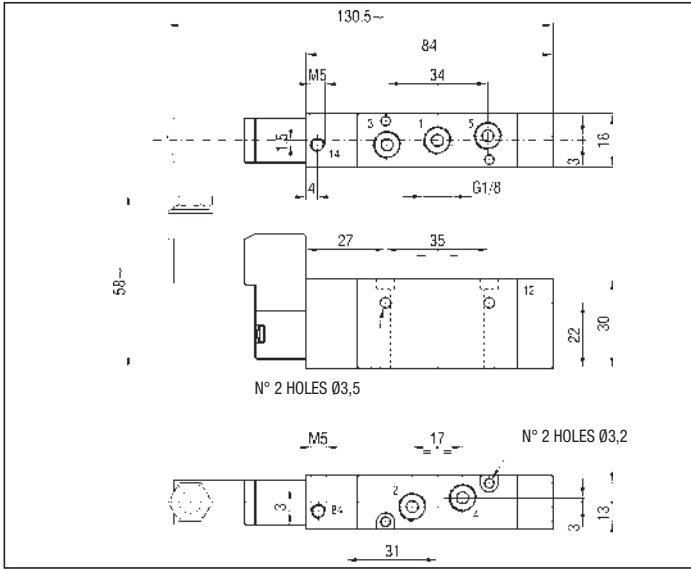

MEKCA8 KUC/KUC

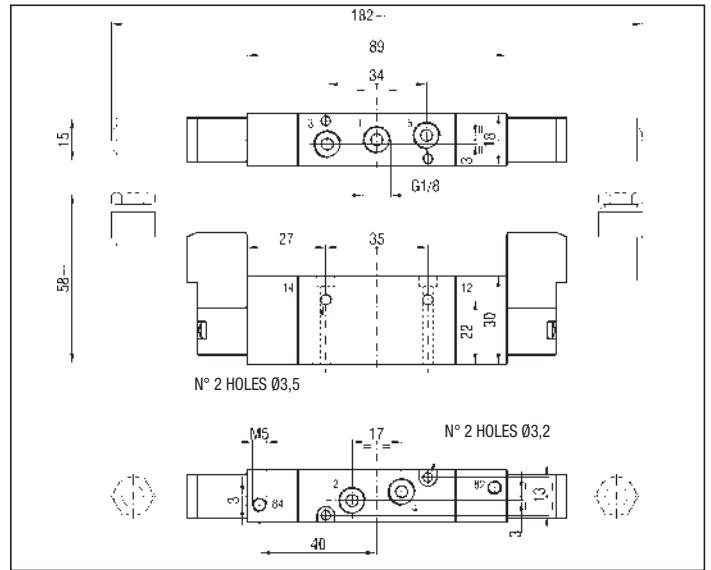

MEKCA8 KUR/KUR

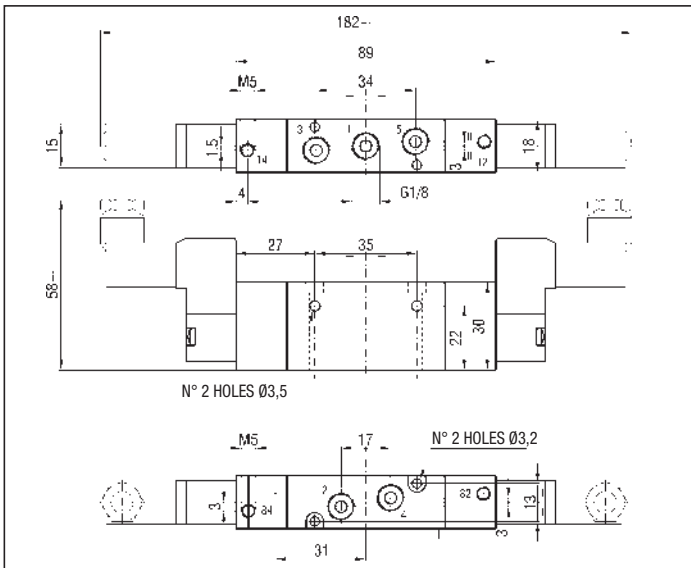

MEKCA8 SUC/SUC - MEKCA8 AUC/AUC - MEKCA8 PUC/PUC

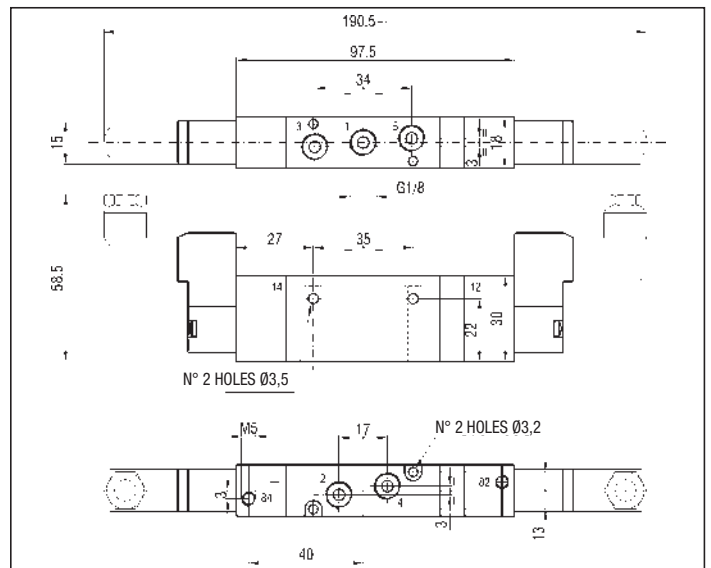

MEKCA8 SUR/SUR - MEKCA8 AUR/AUR - MEKCA8 PUR/PUR

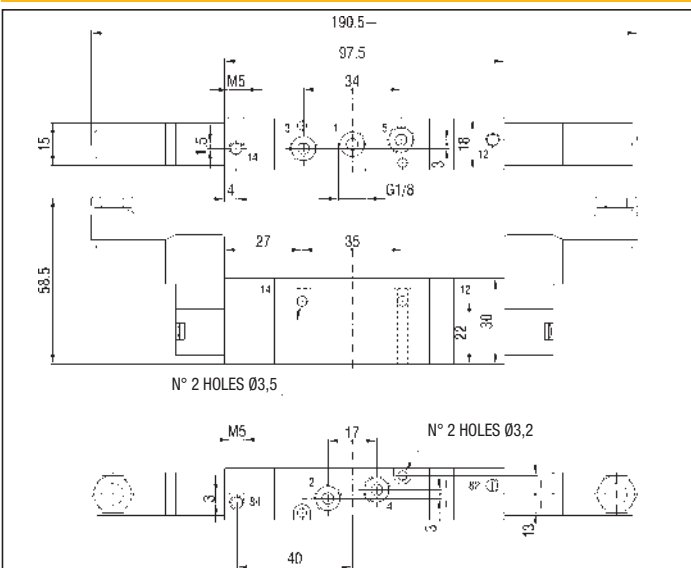

BASE FOR MANIFOLD MOUNTING OF VALVES G 1/8 - KB/MEK8 - Fit for mounting onto DIN 46277/3 rail

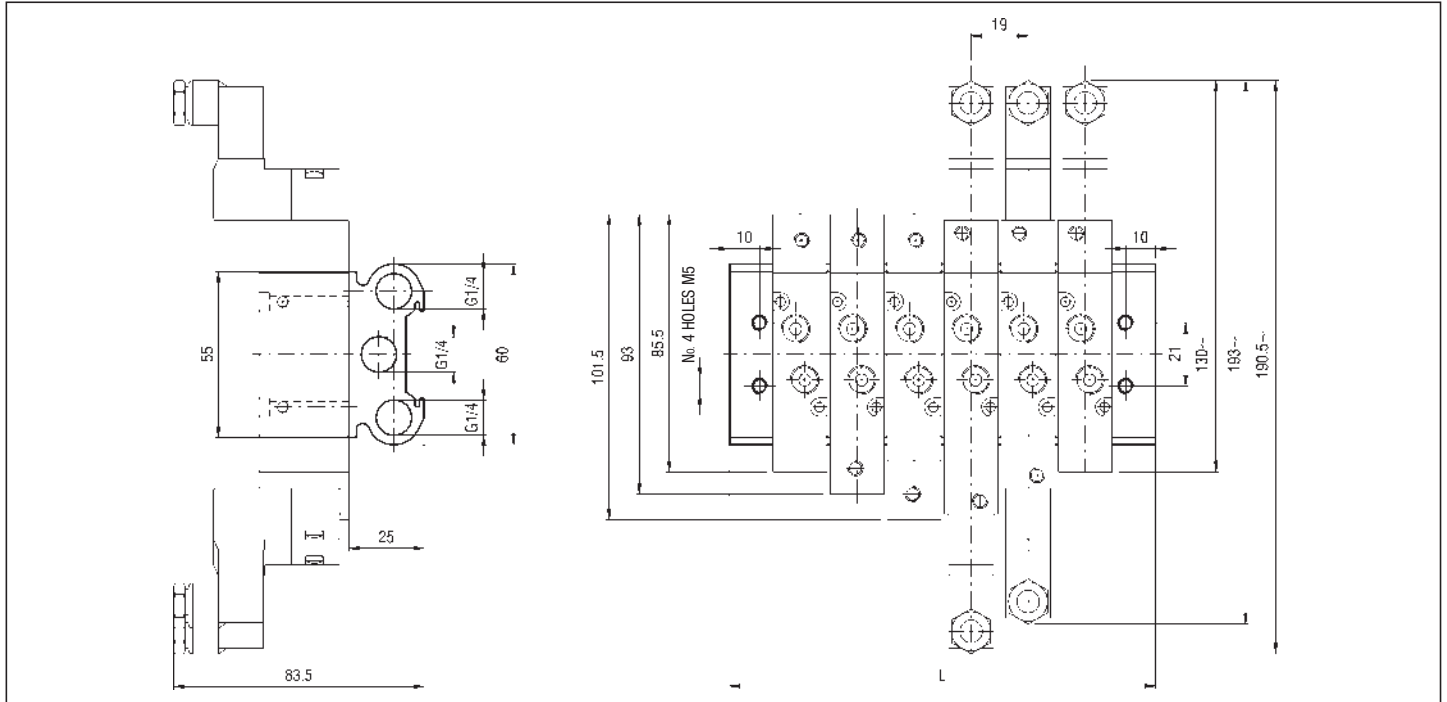

N° of stations	2	3	4	5	6	8	10	12	14	16	18	20
L	66	85	104	123	142	180	218	256	294	332	370	408
Weight (g)	175	220	265	310	355	445	535	625	715	805	895	985
TYPE*	KB/MEK8/2	KB/MEK8/3	KB/MEK8/4	KB/MEK8/5	KB/MEK8/6	KB/MEK8/8	KB/MEK8/10	KB/MEK8/12	KB/MEK8/14	KB/MEK8/16	KB/MEK8/18	KB/MEK8/20

* BASES ARE SUPPLIED COMPLETE WITH SCREWS AND SEALS

BLANKING PLATE - KIT/PC/MEK8

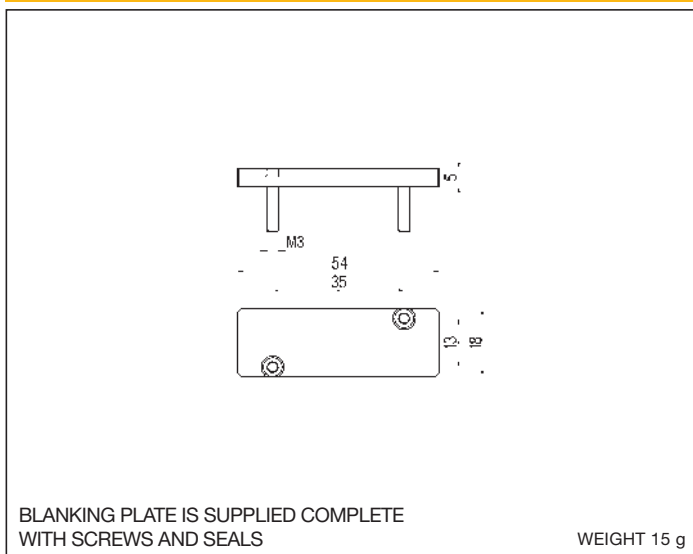
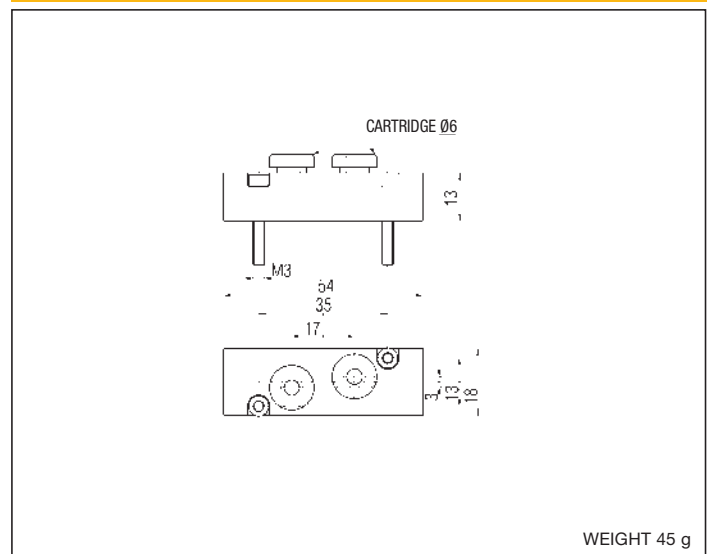

PLATE WITH PUSH-IN FITTING FOR PIPE Ø 6 mm - KIT/IR/MEK8



PILOT ACTUATED VALVES G 1/4

Symbol	Function	Controls		Response time at 6 bar (ms)		Flow rate at 6 bar $\Delta P = 1$ bar (NI/min)	Weight (g)	TYPE
		Pilot	Return	Energized	De-energized			
	5/2 monostable	Pneumatic	Pneumomechanical spring	7	3	900	190	MEKCA4 KR/ZQ
	5/2 bistable	Pneumatic	Pneumatic	5	5	900	215	MEKCA4 KR/KR
	5/3 closed centre	Pneumatic	Mechanical spring	5	15	600	240	MEKCA4 SR/SR
	5/3 open centre	Pneumatic	Mechanical spring	5	15	600	240	MEKCA4 AR/AR
	5/3 pressure centre	Pneumatic	Mechanical spring	5	15	600	240	MEKCA4 PR/PR

MEKCA4 KR/ZQ

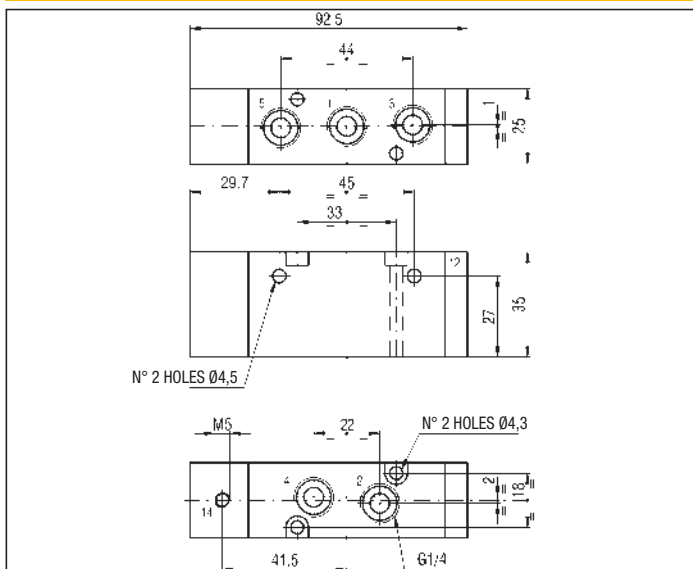

MEKCA4 KR/KR

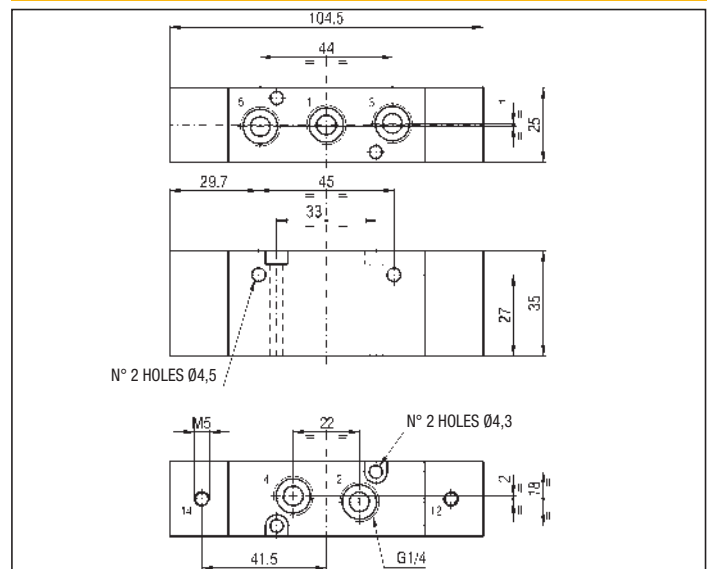

MEKCA4 SR/SR - MEKCA4 AR/AR - MEKCA4 PR/PR

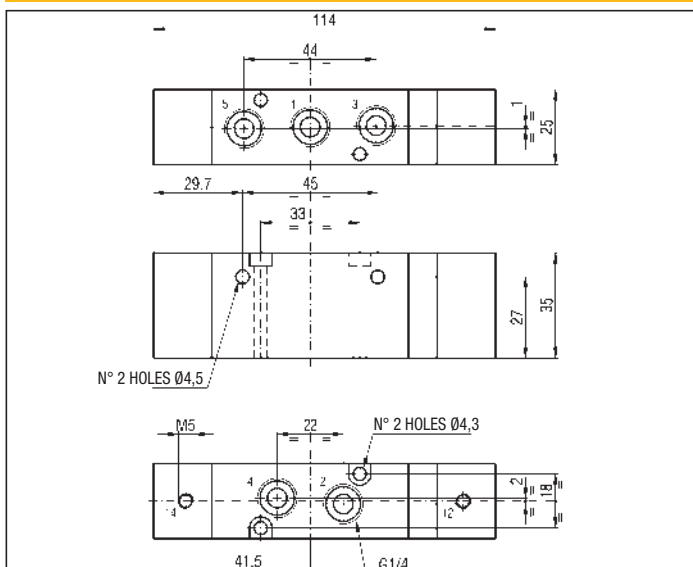

SOLENOID ACTUATED VALVES WITH COIL SIZE 15 mm G 1/4

Symbol	Function	Controls		Response time at 6 bar (ms)		Flow rate at 6 bar $\Delta P = 1 \text{ bar (l/min)}$	Weight (g)	TYPE*
		Pilot	Pilot	Energized	De-energized			
	5/2 monostable	Solenoid	Pneumomechanical spring	15	20	900	225	MEKCA4 KUC/ZQ
		Solenoid pilot assisted	Pneumomechanical spring pilot assisted					MEKCA4 KUR/ZQ
	5/2 bistable	Solenoid	Solenoid	10	10	900	290	MEKCA4 KUC/KUC
		Solenoid pilot assisted	Solenoid pilot assisted					MEKCA4 KUR/KUR
	5/3 closed centre	Solenoid	Mechanical spring	15	30	600	315	MEKCA4 SUC/SUC
		Solenoid pilot assisted	Mechanical spring					MEKCA4 SUR/SUR
	5/3 open centre	Solenoid	Mechanical spring	12	30	600	315	MEKCA4 AUC/AUC
		Solenoid pilot assisted	Mechanical spring					MEKCA4 AUR/AUR
	5/3 pressure centre	Solenoid	Mechanical spring	10	30	600	315	MEKCA4 PUC/PUC
		Solenoid pilot assisted	Mechanical spring					MEKCA4 PUR/PUR

* SPECIFY THE VOLTAGE IN THE ORDER - E.G.: MEKCA4 KUC/ZQ 02450-60
 TYPES OF THE SOLENOID VALVES INCLUDE THE PILOTING SOLENOID VALVES "UMCSV" - SEE ON PAGE 2.3)

02400 = 24 V DC
 02450-60 = 24 V AC

11050-60 = 110 V AC
 22050-60 = 220 V AC

MEKCA4 KUC/ZQ

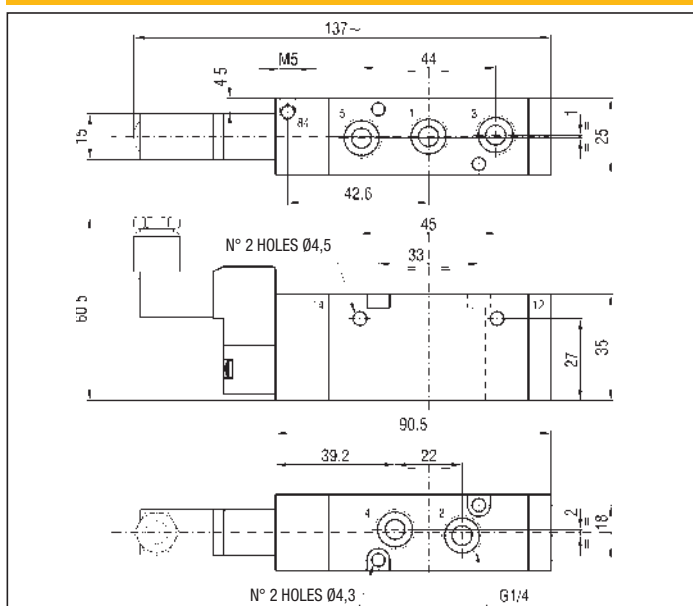

MEKCA4 KUR/ZQ

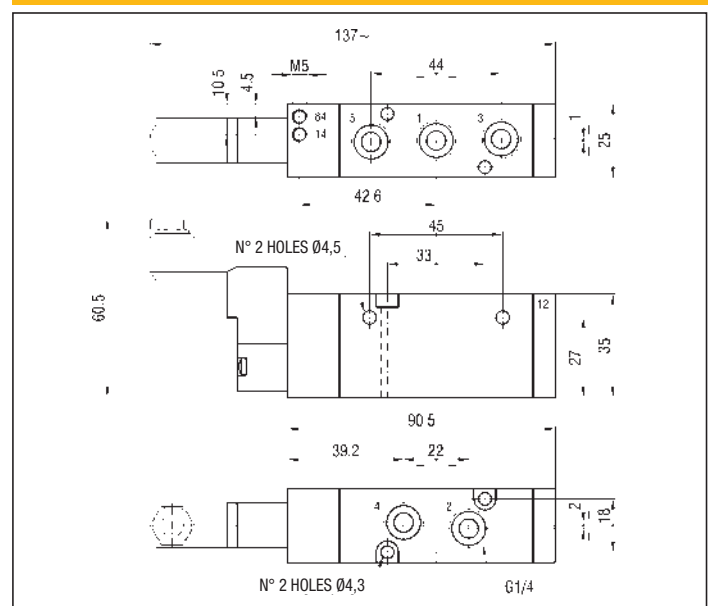

MEKCA4 KUC/KUC

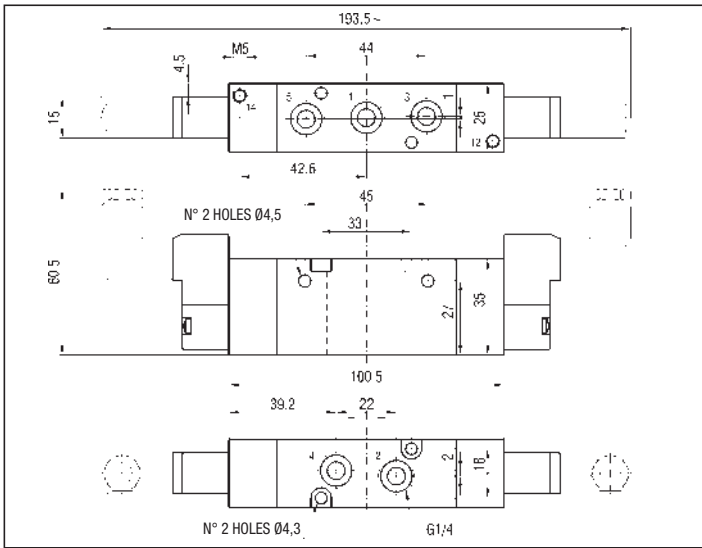

MEKCA4 KUR/KUR

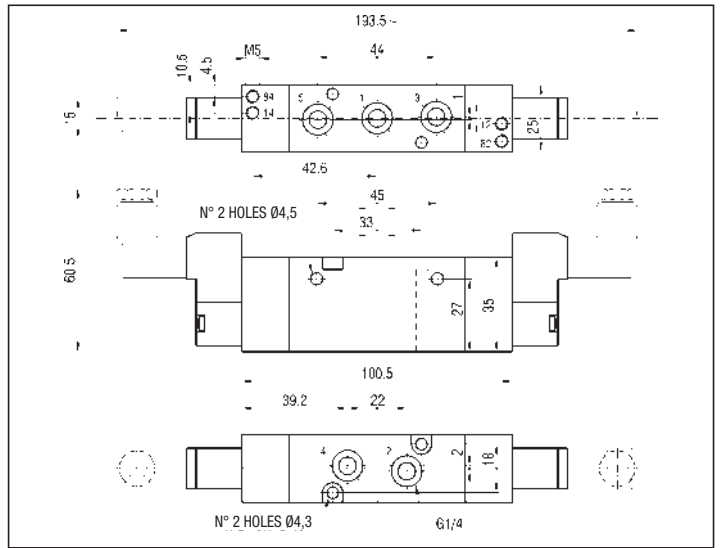

MEKCA4 SUC/SUC - MEKCA4 AUC/AUC - MEKCA4 PUC/PUC

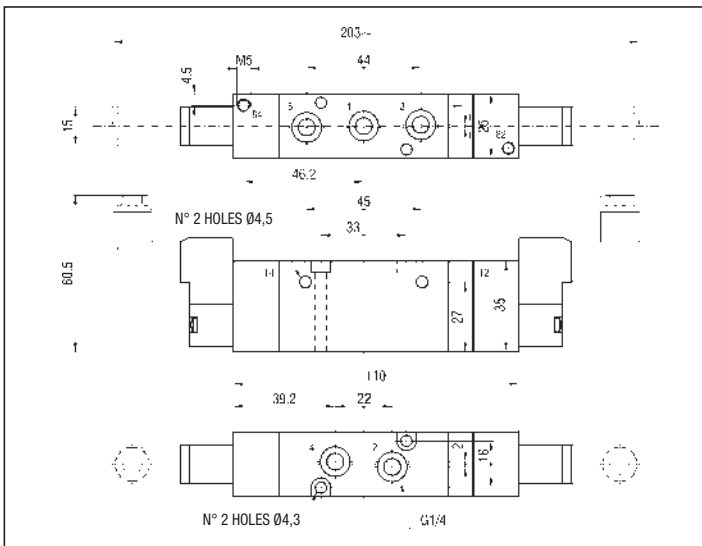

MEKCA4 SUR/SUR - MEKCA4 AUR/AUR - MEKCA4 PUR/PUR

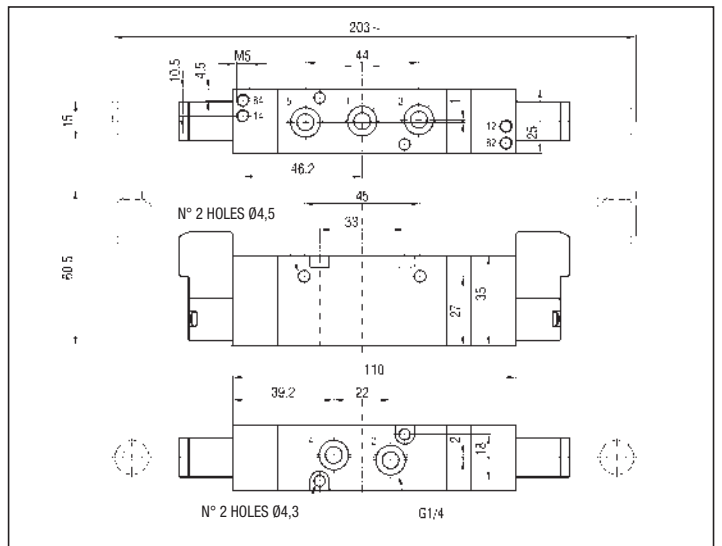

SOLENOID ACTUATED VALVES WITH SLEEVE Ø 9 mm G 1/4

Symbol	Function	Controls		Response time at 6 bar (ms)		Flow rate at 6 bar $\Delta P = 1$ bar (Nl/min)	Weight (g)	TYPE*
		Pilot	Return	Energized	De-energized			
	5/2 monostable	Solenoid	Pneumomechanical spring	22	24	900	210	MEKCA4 KUCG/ZQ
		Solenoid pilot assisted	Pneumomechanical spring pilot assisted					MEKCA4 KURG/ZQ
	5/2 bistable	Solenoid	Solenoid	16	16	900	260	MEKCA4 KUCG/KUCG
		Solenoid pilot assisted	Solenoid pilot assisted					MEKCA4 KURG/KURG
	5/3 closed centre	Solenoid	Mechanical spring	21	30	600	280	MEKCA4 SUCG/SUCG
		Solenoid pilot assisted	Mechanical spring					MEKCA4 SURG/SURG
	5/3 open centre	Solenoid	Mechanical spring	18	30	600	280	MEKCA4 AUCG/AUCG
		Solenoid pilot assisted	Mechanical spring					MEKCA4 AURG/AURG
	5/3 pressure centre	Solenoid	Mechanical spring	15	30	600	280	MEKCA4 PUCG/PUCG
		Solenoid pilot assisted	Mechanical spring					MEKCA4 PURG/PURG

* THE TYPES OF THE SOLENOID VALVES DO NOT INCLUDE COILS

MEKCA4 KUCG/ZQ

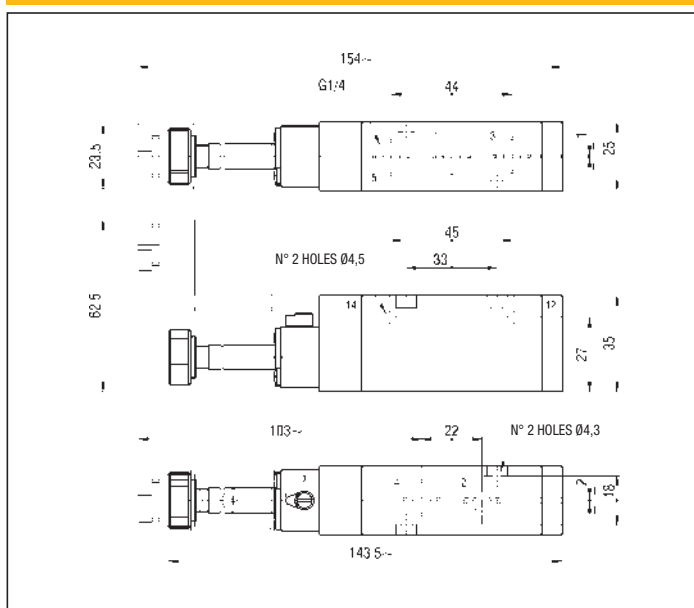

MEKCA4 KURG/ZQ

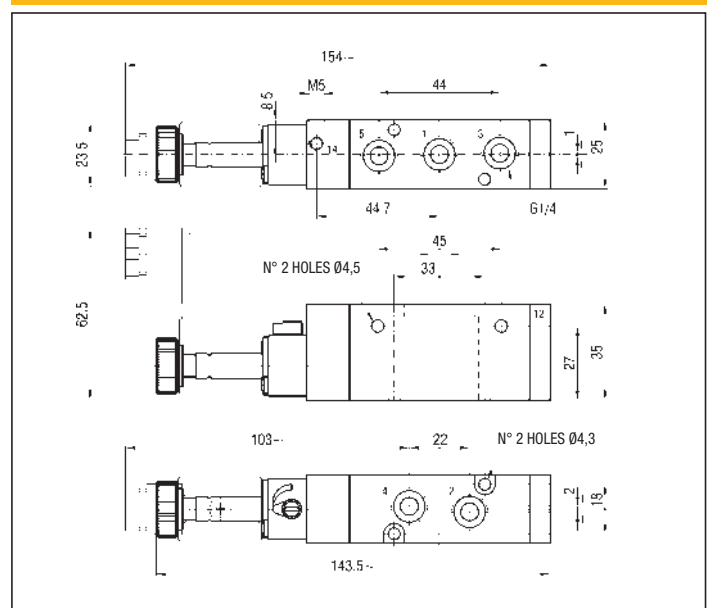

MEKCA4 KUCG/KUCG

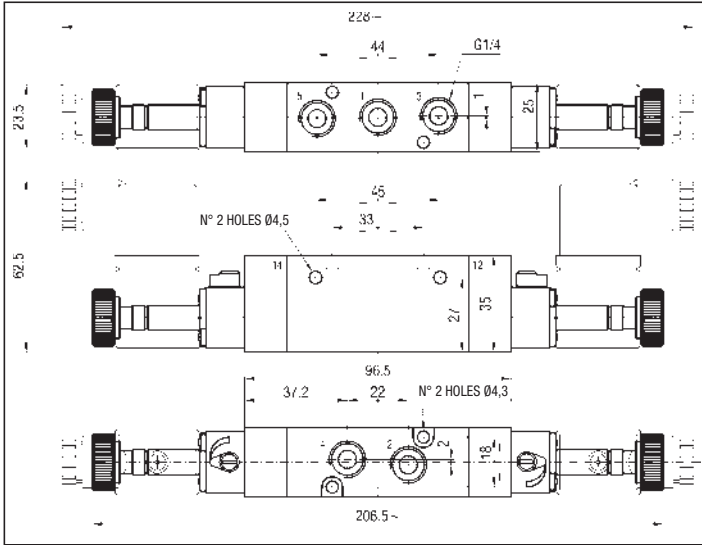

MEKCA4 KURG/KURG

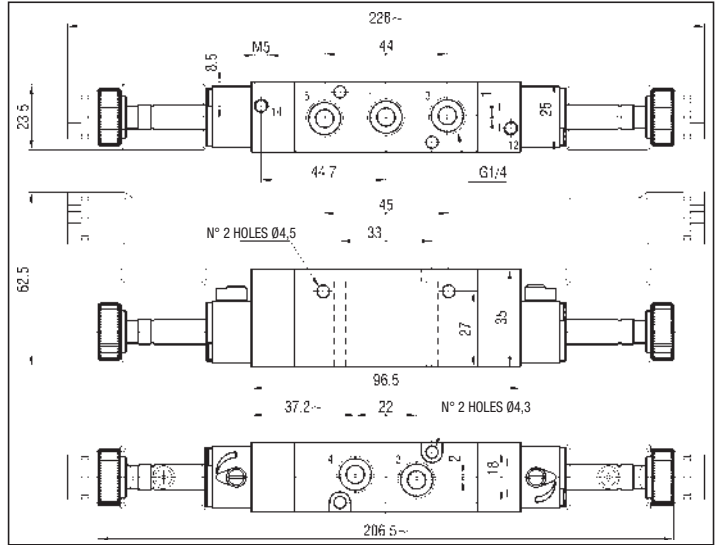

MEKCA4 SUCG/SUCG - MEKCA4 PUCG/PUCG - MEKCA4 AUCG/AUCG

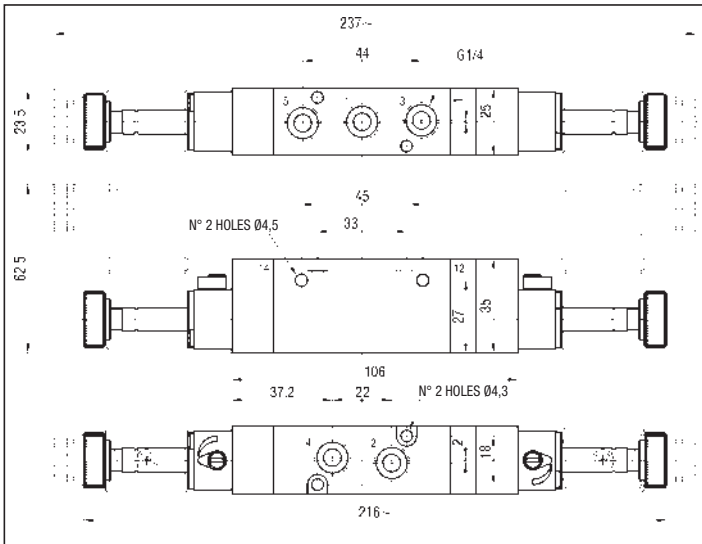

MEKCA4 SURG/SURG - MEKCA4 PURG/PURG - MEKCA4 AURG/AURG

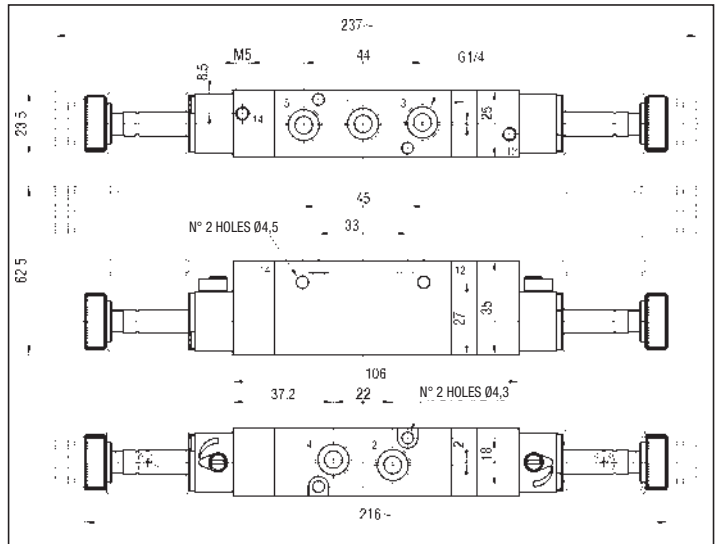

BASE FOR MANIFOLD MOUNTING OF VALVES G 1/4 - KB/MEK4 - Fit for mounting onto DIN 46277/3 rail

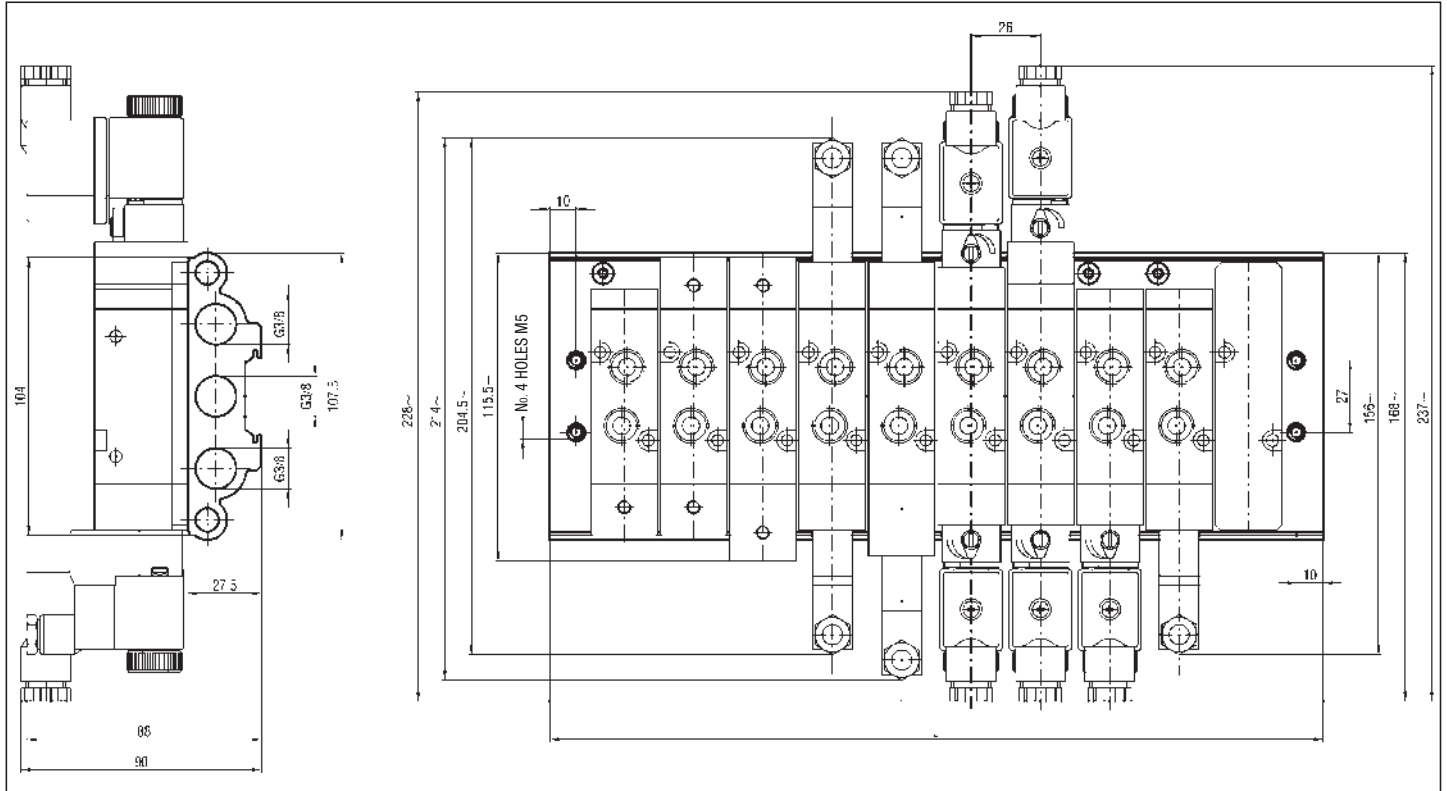

N° of stations	2	3	4	5	6	8	10	12	14	16	18	20
L	82	108	134	160	186	238	290	342	394	446	498	550
Weight (g)	370	475	580	685	790	1000	1210	1220	1630	1840	2050	2260
TYPE*	KB/MEK4/2	KB/MEK4/3	KB/MEK4/4	KB/MEK4/5	KB/MEK4/6	KB/MEK4/8	KB/MEK4/10	KB/MEK4/12	KB/MEK4/14	KB/MEK4/16	KB/MEK4/18	KB/MEK4/20

* BASES ARE SUPPLIED COMPLETE WITH SCREWS AND SEALS

BLANKING PLATE - KIT/PC /MEK4

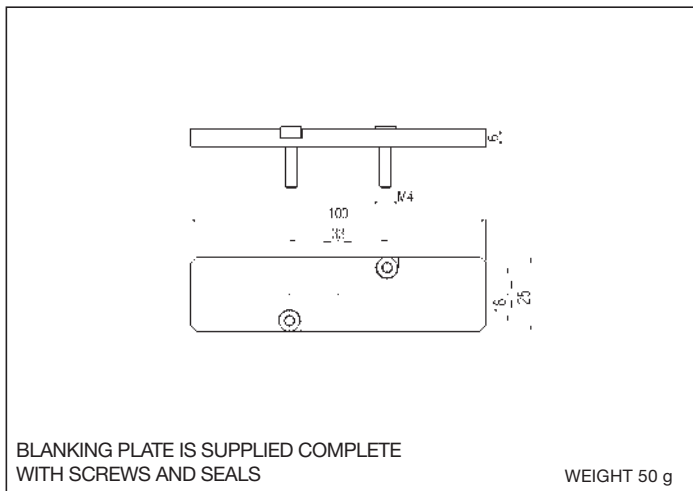
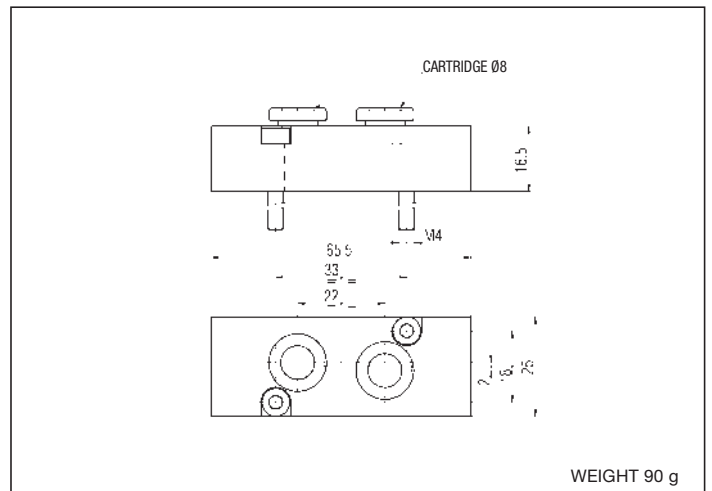

PLATE WITH PUSH-IN FITTING FOR PIPE Ø 8 mm - KIT/IR/MEK4



Spool valves pilot and solenoid actuated G 1/8 - G 1/4 - G 1/2

series EK

DESCRIPTION

Valves series "EK" are produced in the 3/2, 5/2 and 5/3 pneumatic functions. The piloting solenoid valve can be assembled perpendicular respect the body valve, thanks to a suitable bracket. The kind of construction is based on a balanced spool with static seal, being the seals supported by distance rings integral to the body. This series of valves, in the size G 1/8 and G 1/4, is prearranged for both manifold mounting (conveyed inlet and exhausts), or supply rail mounting (conveyed inlet), by means of rear notch screws. The versions size G 1/4 - 5 port are available even with "Namur" port pattern.

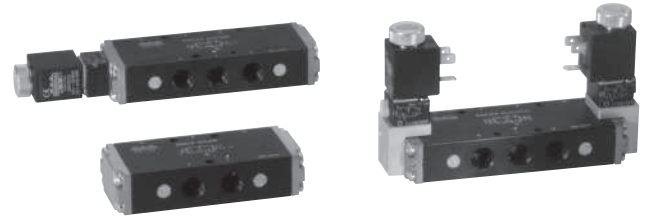

2

TECHNICAL DATA

Operating pressure	Monostable: 2,5 ÷ 10 bar Bistable: 2 ÷ 10 bar
Working temperature	0 ÷ +70 °C (-20 °C with dry air)
Fluid	Filtered, unlubricated or continuous lubricated compressed air
Port size	G 1/8 - G 1/4 - G 1/2
Pneumatic piloting port size	G 1/8
Nominal diameter	G 1/8 = 5 mm; G 1/4 = 7 mm; G 1/2 = 12 mm
Piloting solenoid valve	C/USCSV - see chapter Direct acting solenoid valves on page 2.11
Coils	USB - see chapter Coils on page 2.14 USBG - see chapter Coils on page 2.14*
Electric connectors	USR 102/N9 - see chapter Connectors on page 2.15 ULR1B - see chapter Connectors on page 2.15*

*Only for single valve
(coil and connector overcome the overall dimensions of the valves)

MATERIALS

Bottoms	Anodized aluminium alloy
Body	Anodized aluminium alloy
Distance rings	G 1/8 - G 1/4: Acetal resin G 1/2: Brass
Springs	Galvanized steel
Seals	NBR rubber
Spools	Anodized aluminium alloy
Piston	Anodized aluminium alloy

SPARE PARTS

SEALS KIT	
3 port G 1/8	EK/SG/8
3 port G 1/4	EK/SG/4
3 port G 1/2	EK/SG/2
5 port G 1/8	EKCA/SG/8
5 port G 1/4	EKCA/SG/4
5 port G 1/2	EKCA/SG/2
5 port G 1/4 Namur	ENCA/SG/4

FLOW CHART - EK G 1/8 - 5/2

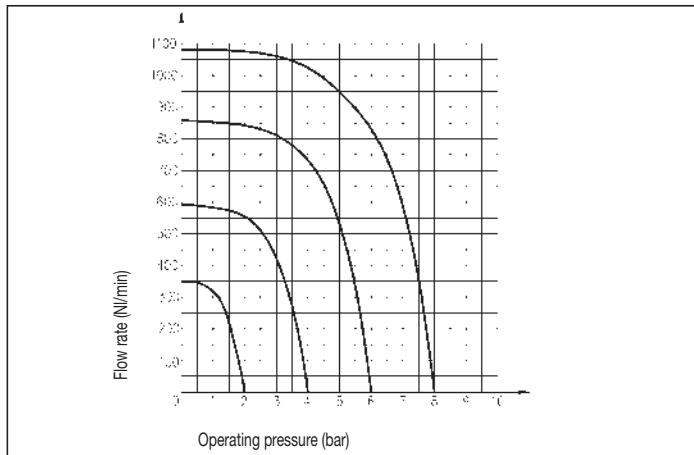

PILOTING CHART - EK G 1/8

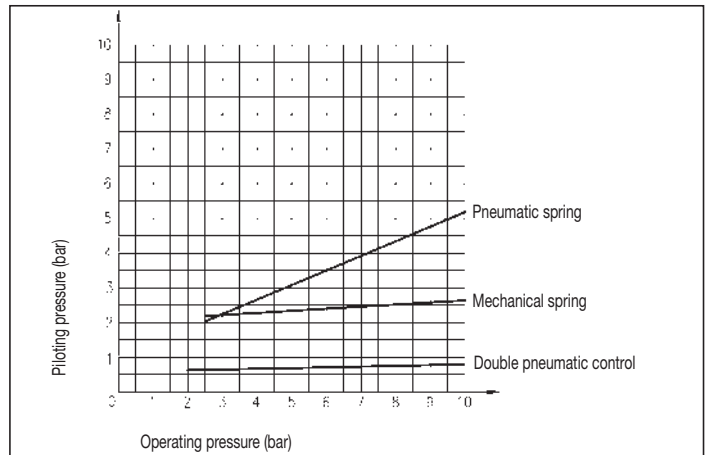

FLOW CHART - EK G 1/4 - 5/2

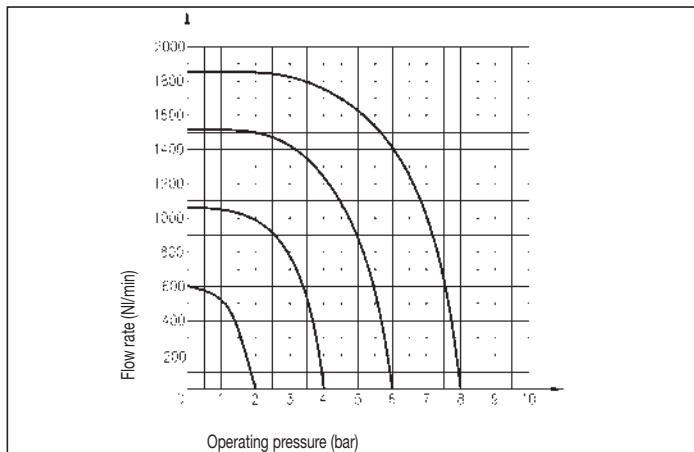

PILOTING CHART - EK G 1/4

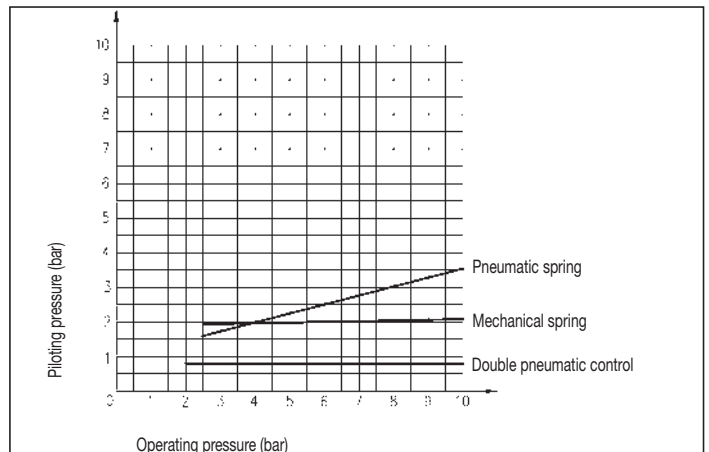

2

FLOW CHART - EK G 1/2 - 5/2

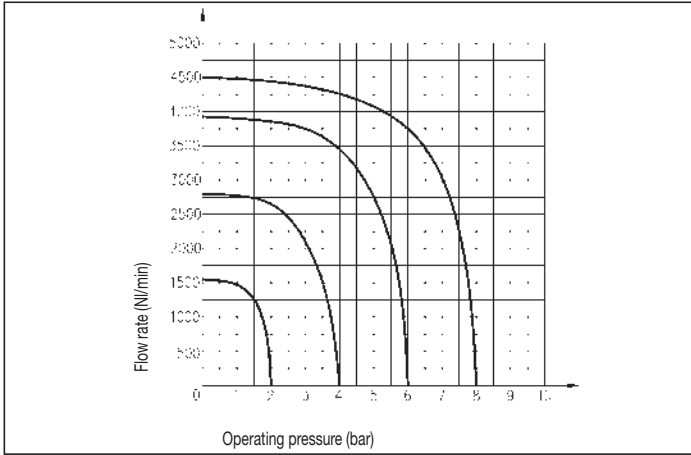

PILOTING CHART - EK G 1/2

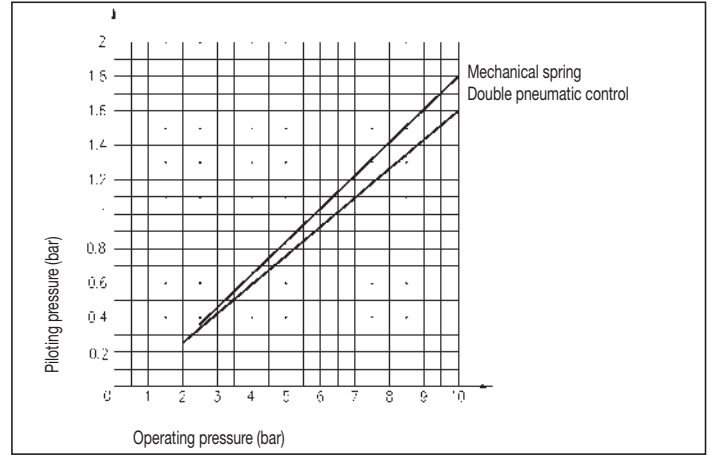

PILOT ACTUATED VALVES G 1/8 - 3 PORT

Symbol	Function	Controls		Response time at 6 bar (ms)		Flow rate at 6 bar $\Delta P = 1$ bar (NL/min)	Weight (g)	TYPE
		Pilot	Return	Energized	De-energized			
	3/2 N.A. monostable	Pneumatic	Pneumatic spring	18	10	550	220	EKA8 KR/ZR
		Pneumatic	Pneumatic spring	26	16			
	3/2 N.C. monostable	Pneumatic	Pneumatic spring	14	8	550	220	EKC8 KR/ZR
		Pneumatic	Pneumatic spring	30	28			
	3/2 bistable	Pneumatic	Pneumatic	10	10	550	215	EK8 KR/KR
		Pneumatic	Pneumatic differential	10	15			

3 PORT

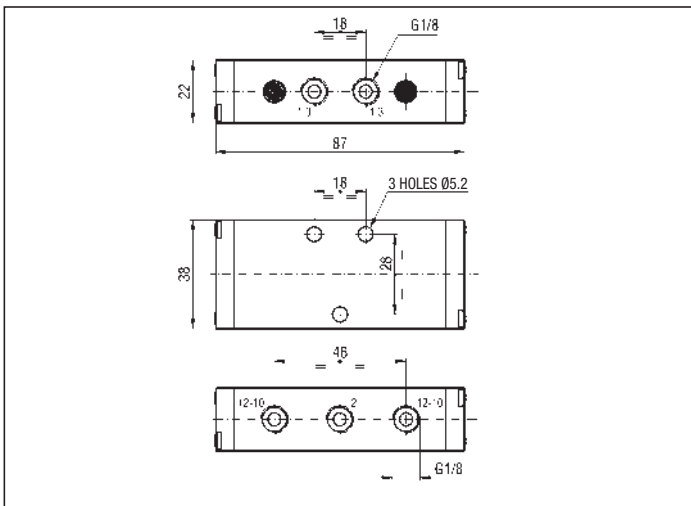

PILOT ACTUATED VALVES G 1/8 - 5 PORT

Symbol	Function	Controls		Response time at 6 bar (ms)		Flow rate at 6 bar $\Delta P = 1$ bar (l/min)	Weight (g)	TYPE
		Pilot	Return	Energized	De-energized			
	5/2 monostable	Pneumatic	Mechanical spring	20	10	550	270	EKCA8 KR/ZR
		Pneumatic	Mechanical spring	25	15	550	260	EKCA8 KR/TQ
	5/2 bistable	Pneumatic	Pneumatic	10	10	550	230	EKCA8 KR/KR
		Pneumatic	Pneumatic differential	12	15	550	230	EKCA8 KR/TR
	5/3 closed centre	Pneumatic	Mechanical spring	18	25	425	285	EKCA8 SR/SR
	5/3 open centre	Pneumatic	Mechanical spring	18	25	500	285	EKCA8 AR/AR
	5/3 pressure centre	Pneumatic	Mechanical spring	15	20	425	285	EKCA8 PR/PR

5 PORT

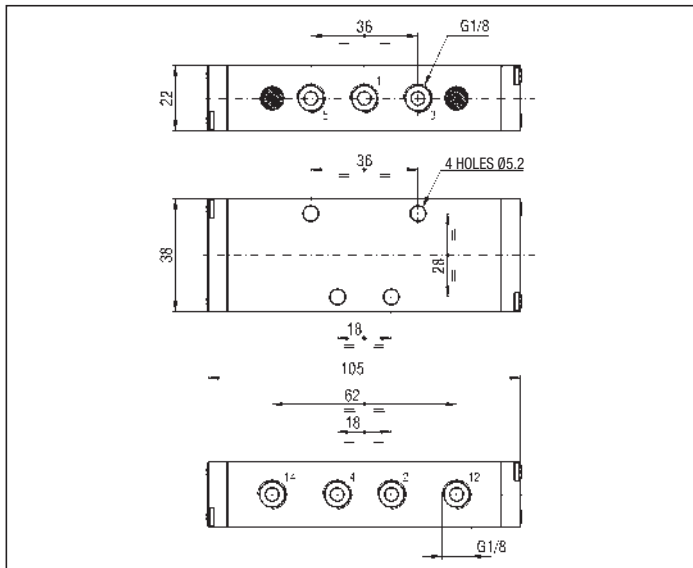

SOLENOID ACTUATED VALVES G 1/8 - 3 PORT

Symbol	Function	Controls		Response time at 6 bar (ms)		Flow rate at 6 bar $\Delta P = 1$ bar (NI/min)	Weight (g)	TYPE*
		Pilot	Return	Energized	De-energized			
	3/2 N.O. monostable	Solenoid	Mechanical spring	24	28	550	250	EKA8 KUC/ZR
		Solenoid	Pneumatic spring	18	27	550	245	EKA8 KUC/TQ
		Solenoid pilot assisted	Mechanical spring	24	28	550	250	EKA8 KUR/ZR
	3/2 N.C. monostable	Solenoid	Mechanical spring	32	31	550	250	EKC8 KUC/ZR
		Solenoid	Pneumatic spring	22	28	550	245	EKC8 KUC/TQ
		Solenoid pilot assisted	Mechanical spring	32	31	550	250	EKC8 KUR/ZR
	3/2 bistable	Solenoid	Solenoid	21	21	550	290	EK8 KUC/KUC
		Solenoid pilot assisted	Solenoid pilot assisted	21	21	550	290	EK8 KUR/KUR

P.S.: SUBSTITUTE THE LETTER "U" WITH THE LETTER "L" IN EACH SOLENOID CONTROL TYPE TO ORDER THE SOLENOID ACTUATED VALVES WITH SOLENOID AT 90° RESPECT THE BODY OF THE VALVE. E.G.: EKC8 KUC/TQ BECOMES EKC8 KLC/TQ (SEE ON PAGE 2.59 FOR THE MISSING DIMENSIONS)

*THE TYPES OF THE SOLENOID VALVES DO NOT INCLUDE COILS

3 PORT MONOSTABLE

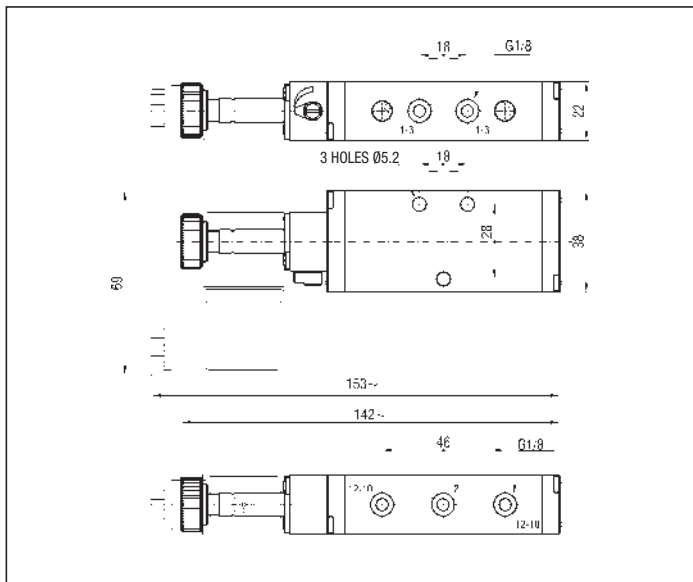

3 PORT BISTABLE

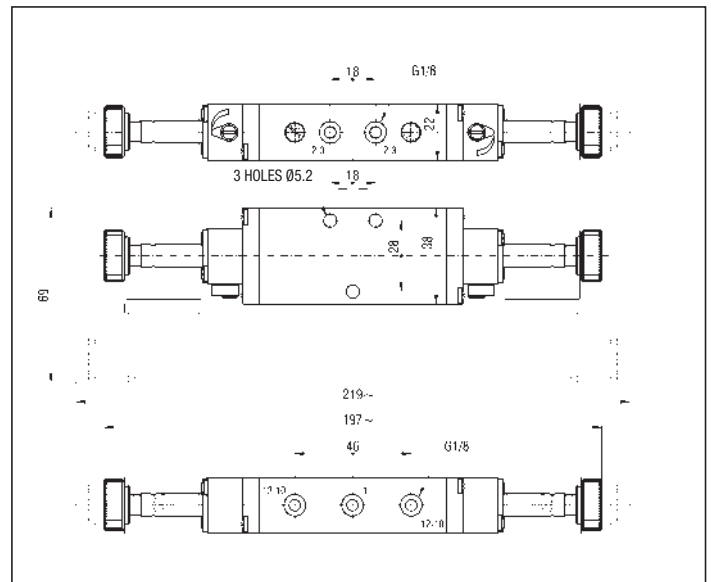

SOLENOID ACTUATED VALVES G 1/8 - 5 PORT

Symbol	Function	Controls		Response time at 6 bar (ms)		Flow rate at 6 bar $\Delta P = 1 \text{ bar (l/min)}$	Weight (g)	TYPE*
		Pilot	Return	Energized	De-energized			
	5/2 monostable	Solenoid	Mechanical spring	20	30	550	300	EKCA8 KUC/ZR
		Solenoid	Pneumatic spring	27	39	550	300	EKCA8 KUC/TQ
		Solenoid pilot assisted	Mechanical spring	20	30	550	300	EKCA8 KUR/ZR
	5/2 bistable	Solenoid	Solenoid	18	18	550	325	EKCA8 KUC/KUC
		Solenoid pilot assisted	Solenoid pilot assisted	18	18	550	325	EKCA8 KUR/KUR
	5/3 closed centre	Solenoid	Mechanical spring	23	37	425	335	EKCA8 SUC/SUC
		Solenoid pilot assisted	Mechanical spring	23	37	425	335	EKCA8 SUR/SUR
	5/3 open centre	Solenoid	Mechanical spring	23	37	500	345	EKCA8 AUC/AUC
		Solenoid pilot assisted	Mechanical spring	23	37	500	345	EKCA8 AUR/AUR
	5/3 pressure centre	Solenoid	Mechanical spring	20	35	425	335	EKCA8 PUC/PUC
		Solenoid pilot assisted	Mechanical spring	20	25	425	335	EKCA8 PUR/PUR

P.S.: SUBSTITUTE THE LETTER "U" WITH THE LETTER "L" IN EACH SOLENOID CONTROL TYPE TO ORDER THE SOLENOID ACTUATED VALVES WITH SOLENOID AT 90° RESPECT THE BODY OF THE VALVE. E.G.: EKCA8 KUC/TQ BECOMES EKCA8 KLC/TQ (SEE ON PAGE 2.59 FOR THE MISSING DIMENSIONS)
*THE TYPES OF THE SOLENOID VALVES DO NOT INCLUDE COILS

5 PORT MONOSTABLE

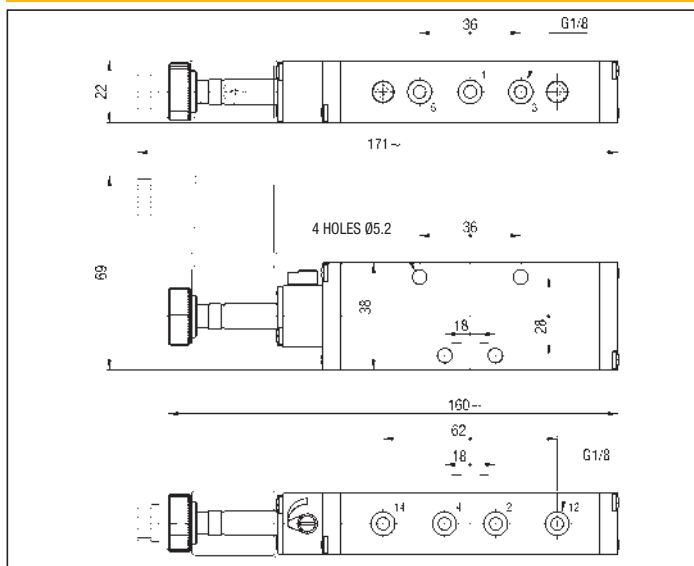

5 PORT AND 3 POSITION BISTABLE

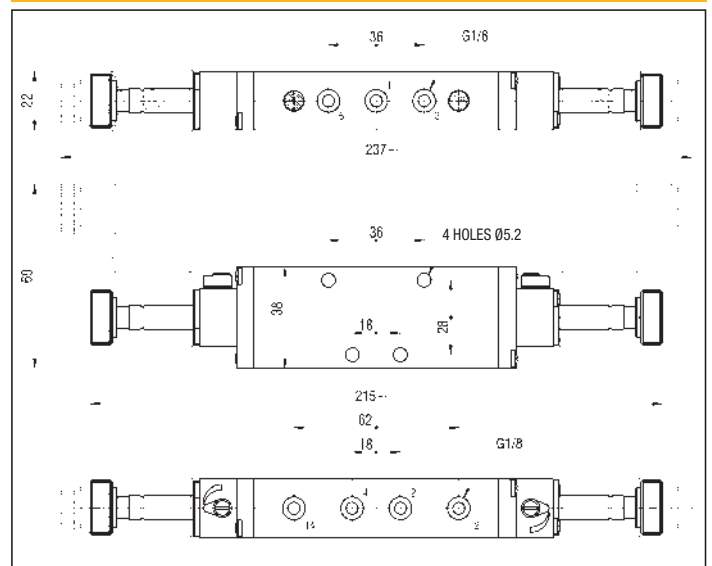

2

BASE FOR MANIFOLD MOUNTING OF VALVES G 1/8 - KB/EK8

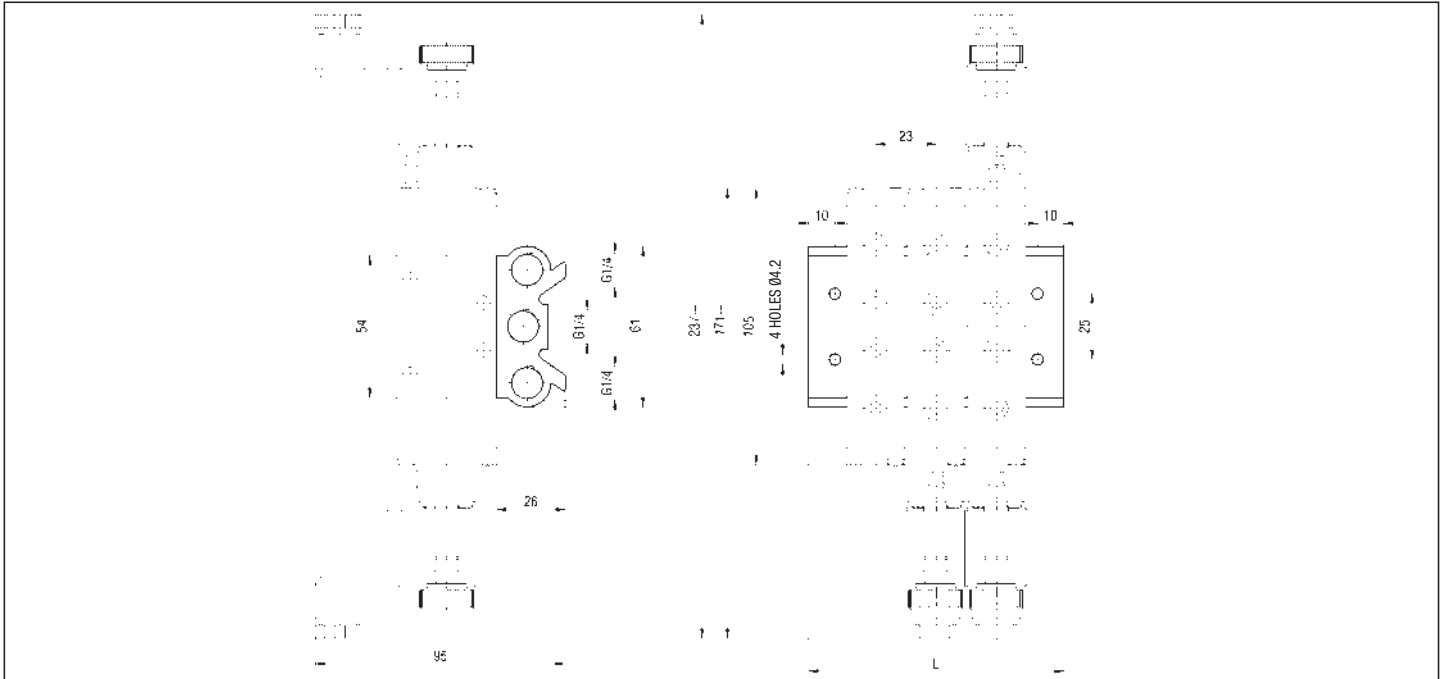

No. of stations	2	3	4	5	6	8	10	12	14	16	18	20
L	74	97	120	143	166	212	258	304	350	396	442	488
Weight (g)	220	285	350	415	480	610	740	870	1000	1130	1260	1390
TYPE*	KB/EK8/2	KB/EK8/3	KB/EK8/4	KB/EK8/5	KB/EK8/6	KB/EK8/8	KB/EK8/10	KB/EK8/12	KB/EK8/14	KB/EK8/16	KB/EK8/18	KB/EK8/20

* BASES ARE SUPPLIED COMPLETE WITH NOTCH SCREWS AND SEALS

SUPPLY RAIL FOR MANIFOLD MOUNTING OF VALVES G 1/8 - CEK8

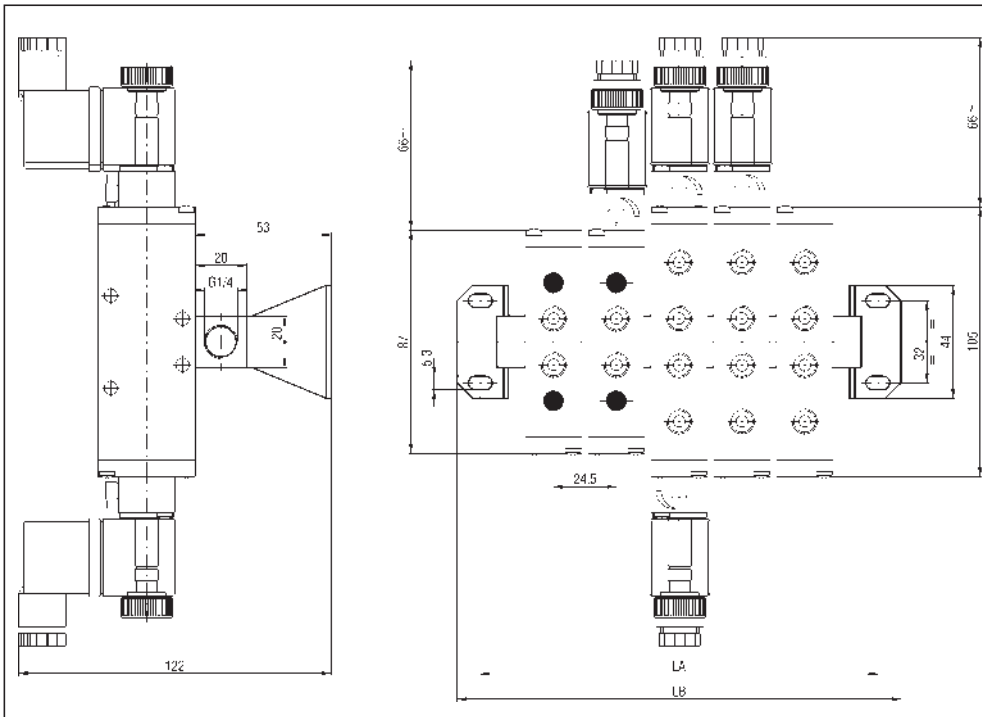

No. of stations	2	3	5
LA	83	105	150
LB	101	123	168
Weight (g)	135	170	240
TYPE*	CEK8/2	CEK8/3	CEK8/5

* SUPPLY RAILS ARE SUPPLIED COMPLETE WITH NOTCH SCREWS, SEALS AND FIXING BRACKETS

BLANKING PLATE - KIT /PC/EK8

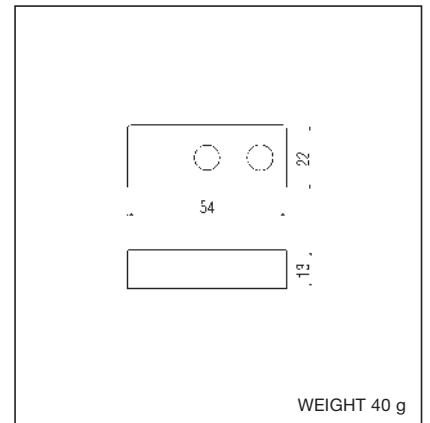

PILOT ACTUATED VALVES G 1/4 - 3 PORT

Symbol	Function	Controls		Response time at 6 bar (ms)		Flow rate at 6 bar $\Delta P = 1$ bar (l/min)	Weight (g)	TYPE
		Pilot	Return	Energized	De-energized			
	3/2 N.O. monostable	Pneumatic	Mechanical spring	21	14	950	335	EKA4 KR/ZR
		Pneumatic	Pneumatic spring	28	10			
	3/2 N.C. monostable	Pneumatic	Mechanical spring	21	14	950	335	EKC4 KR/ZR
		Pneumatic	Pneumatic spring	25	11			
	3/2 bistable	Pneumatic	Pneumatic	11	11	950	330	EK4 KR/KR
		Pneumatic	Pneumatic differential	10	18			

3 PORT

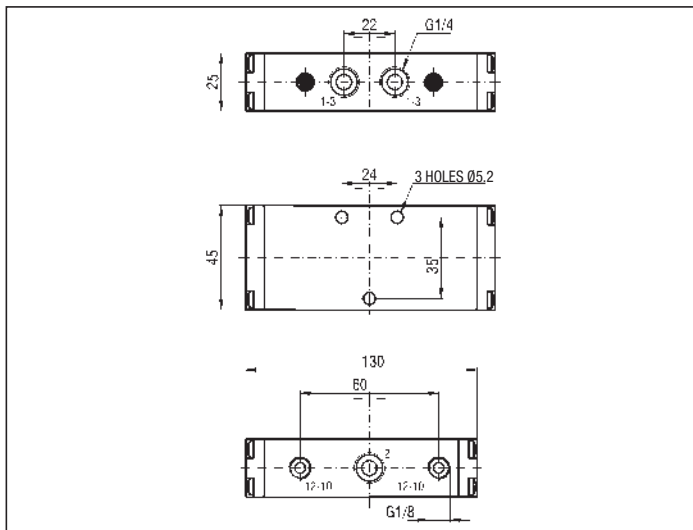

2

PILOT ACTUATED VALVES G 1/4 - 5 PORT

Symbol	Function	Controls		Response time at 6 bar (ms)		Flow rate at 6 bar $\Delta P = 1$ bar (NI/min)	Weight (g)	TYPE
		Pilot	Return	Energized	De-energized			
	5/2 monostable	Pneumatic	Mechanical spring	18	14	900	385	EKCA4 KR/ZR
		Pneumatic	Pneumatic spring	25	11	900	370	EKCA4 KR/TQ
	5/2 bistable	Pneumatic	Pneumatic	11	11	900	370	EKCA4 KR/KR
		Pneumatic	Pneumatic differential	10	20	900	370	EKCA4 KR/TR
	5/3 closed centre	Pneumatic	Mechanical spring	20	14	510	420	EKCA4 SR/SR
	5/3 open centre	Pneumatic	Mechanical spring	20	14	850	415	EKCA4 AR/AR
	5/3 pressure centre	Pneumatic	Mechanical spring	20	14	690	415	EKCA4 PR/PR

5 PORT

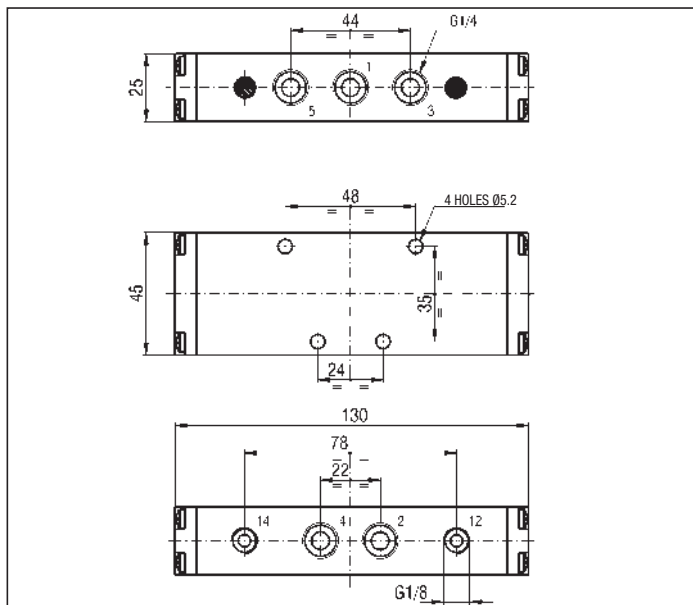

PILOT ACTUATED VALVES "NAMUR" PORT PATTERN - G 1/4 - 5 PORT

Symbol	Function	Controls		Response time at 6 bar (ms)		Flow rate at 6 bar $\Delta P = 1 \text{ bar (l/min)}$	Weight (g)	TYPE
		Pilot	Return	Energized	De-energized			
	5/2 monostable	Pneumatic	Mechanical spring	18	14	900	390	ENCA4 KR/ZR
		Pneumatic	Pneumatic spring	25	11	900	375	ENCA4 KR/TQ
	5/2 bistable	Pneumatic	Pneumatic	11	11	900	375	ENCA4 KR/KR
		Pneumatic	Pneumatic differential	10	20	900	375	ENCA4 KR/TR
	5/3 closed centre	Pneumatic	Mechanical spring	20	14	510	425	ENCA4 SR/SR
	5/3 open centre	Pneumatic	Mechanical spring	20	14	850	420	ENCA4 AR/AR
	5/3 pressure centre	Pneumatic	Mechanical spring	20	14	690	420	ENCA4 PR/PR

"NAMUR" PORT PATTERN - 5 PORT

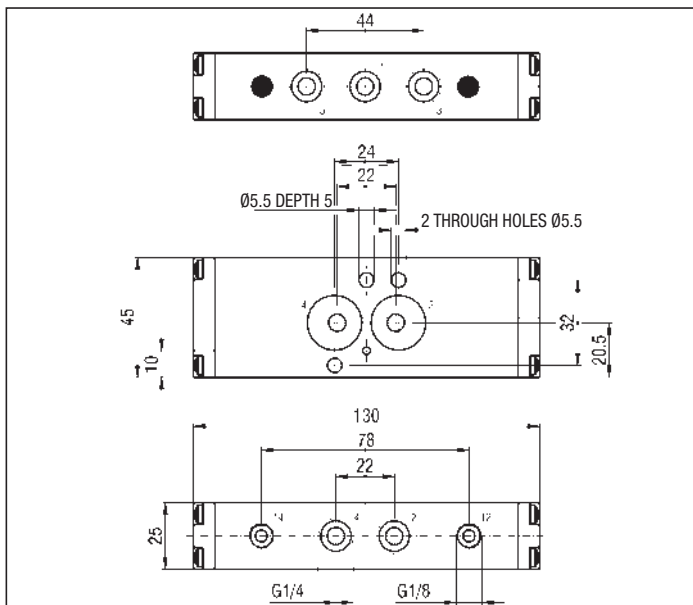

SOLENOID ACTUATED VALVES G 1/4 - 3 PORT

Symbol	Function	Controls		Response time at 6 bar (ms)		Flow rate at 6 bar $\Delta P = 1 \text{ bar (l/min)}$	Weight (g)	TYPE*
		Pilot	Return	Energized	De-energized			
	3/2 N.O. monostable	Solenoid	Mechanical spring	22	60	950	385	EKA4 KUC/ZR
		Solenoid	Pneumatic spring	24	50	950	370	EKA4 KUC/TQ
		Solenoid pilot assisted	Mechanical spring	22	60	950	385	EKA4 KUR/ZR
	3/2 N.C. monostable	Solenoid	Mechanical spring	22	60	950	385	EKC4 KUC/ZR
		Solenoid	Pneumatic spring	24	50	950	370	EKC4 KUC/TQ
		Solenoid pilot assisted	Mechanical spring	22	60	950	385	EKC4 KUR/ZR
	3/2 bistable	Solenoid	Solenoid	23	23	950	405	EK4 KUC/KUC
		Solenoid pilot assisted	Solenoid pilot assisted	23	23	950	405	EK4 KUR/KUR

PS.: SUBSTITUTE THE LETTER "U" WITH THE LETTER "L" IN EACH SOLENOID CONTROL TYPE TO ORDER THE SOLENOID ACTUATED VALVES WITH SOLENOID AT 90° RESPECT THE BODY OF THE VALVE. E.G.: EKC4 KUC/TQ BECOMES EKC4 KLC/TQ (SEE ON PAGE 2.59 FOR THE MISSING DIMENSIONS)

*THE TYPES OF THE SOLENOID VALVES DO NOT INCLUDE COILS

3 PORT MONOSTABLE

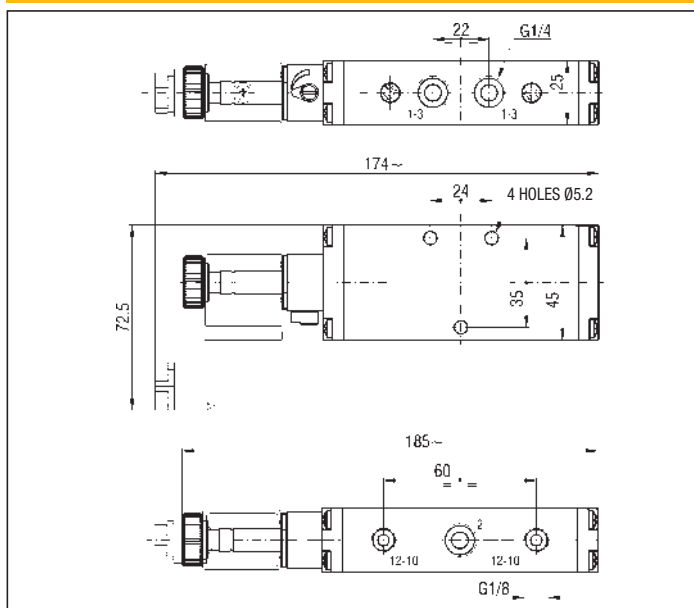

3 PORT BISTABLE

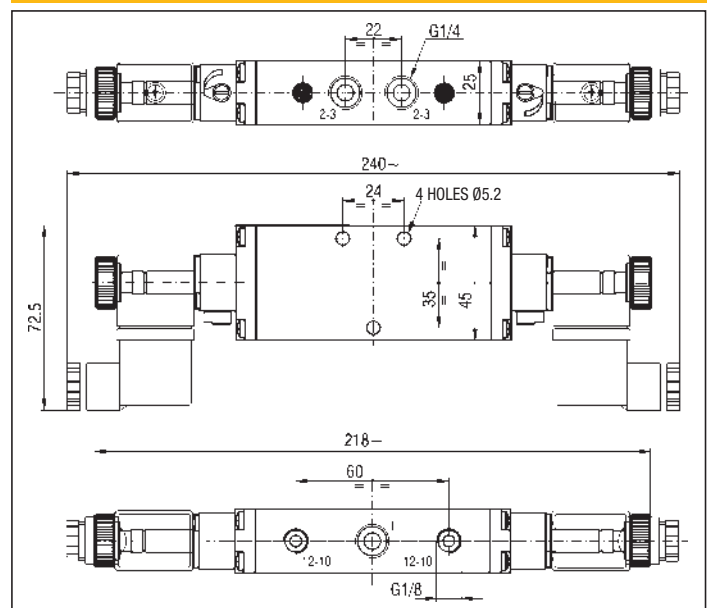

SOLENOID ACTUATED VALVES G 1/4 - 5 PORT

Symbol	Function	Controls		Response time at 6 bar (ms)		Flow rate at 6 bar $\Delta P = 1 \text{ bar (l/min)}$	Weight (g)	TYPE*
		Pilot	Return	Energized	De-energized			
	5/2 monostable	Solenoid	Mechanical spring	32	65	900	430	EKCA4 KUC/ZR
		Solenoid	Pneumatic spring	32	65	900	415	EKCA4 KUC/TQ
		Solenoid pilot assisted	Mechanical spring	32	65	900	430	EKCA4 KUR/ZR
	5/2 bistable	Solenoid	Solenoid	21	21	900	475	EKCA4 KUC/KUC
		Solenoid pilot assisted	Solenoid pilot assisted	21	21	900	475	EKCA4 KUR/KUR
	5/3 closed centre	Solenoid	Mechanical spring	25	50	510	490	EKCA4 SUC/SUC
		Solenoid pilot assisted	Mechanical spring	25	50	510	490	EKCA4 SUR/SUR
	5/3 open centre	Solenoid	Mechanical spring	25	50	850	485	EKCA4 AUC/AUC
		Solenoid pilot assisted	Mechanical spring	25	50	850	485	EKCA4 AUR/AUR
	5/3 pressure centre	Solenoid	Mechanical spring	25	50	690	490	EKCA4 PUC/PUC
		Solenoid pilot assisted	Mechanical spring	25	50	690	490	EKCA4 PUR/PUR

PS.: SUBSTITUTE THE LETTER "U" WITH THE LETTER "L" IN EACH SOLENOID CONTROL TYPE TO ORDER THE SOLENOID ACTUATED VALVES WITH SOLENOID AT 90° RESPECT THE BODY OF THE VALVE. E.G.: EKCA4 KUC/TQ BECOMES EKCA4 KLC/TQ (SEE ON PAGE 2.59 FOR THE MISSING DIMENSIONS)

*THE TYPES OF THE SOLENOID VALVES DO NOT INCLUDE COILS

5 PORT MONOSTABLE

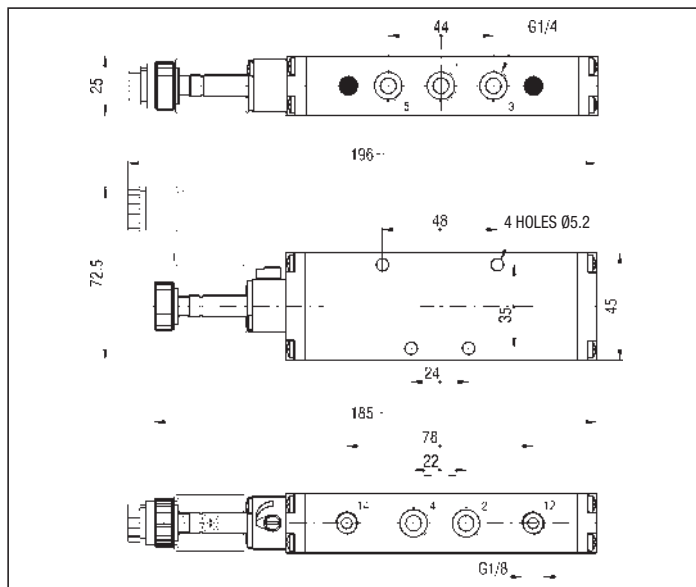

5 PORT AND 3 POSITION BISTABLE

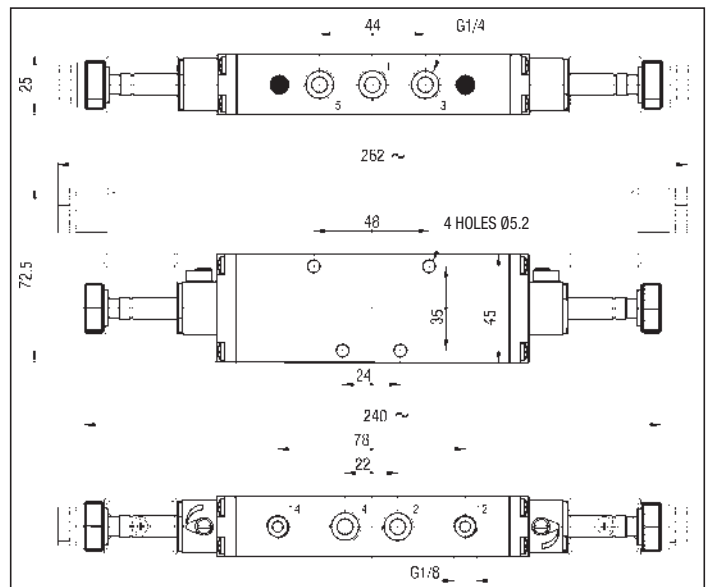

2

SOLENOID ACTUATED VALVES "NAMUR" PORT PATTERN - G 1/4 - 5 PORT

Symbol	Function	Controls		Response time at 6 bar (ms)		Flow rate at 6 bar $\Delta P = 1 \text{ bar (l/min)}$	Weight (g)	TYPE*
		Pilot	Return	Energized	De-energized			
	5/2 monostable	Solenoid	Mechanical spring	32	65	900	440	ENCA4 KUC/ZR
		Solenoid	Pneumatic spring	32	65	900	425	ENCA4 KUC/TQ
		Solenoid pilot assisted	Mechanical spring	32	65	900	440	ENCA4 KUR/ZR
	5/2 bistable	Solenoid	Solenoid	21	21	900	485	ENCA4 KUC/KUC
		Solenoid pilot assisted	Solenoid pilot assisted	21	21	900	485	ENCA4 KUR/KUR
	5/3 closed centre	Solenoid	Mechanical spring	25	50	510	500	ENCA4 SUC/SUC
		Solenoid pilot assisted	Mechanical spring	25	50	510	500	ENCA4 SUR/SUR
	5/3 open centre	Solenoid	Mechanical spring	25	50	850	495	ENCA4 AUC/AUC
		Solenoid pilot assisted	Mechanical spring	25	50	850	495	ENCA4 AUR/AUR
	5/3 pressure centre	Solenoid	Mechanical spring	25	50	690	500	ENCA4 PUC/PUC
		Solenoid pilot assisted	Mechanical spring	25	50	690	500	ENCA4 PUR/PUR

P.S.: SUBSTITUTE THE LETTER "U" WITH THE LETTER "L" IN EACH SOLENOID CONTROL TYPE TO ORDER THE SOLENOID ACTUATED VALVES WITH SOLENOID AT 90° RESPECT THE BODY OF THE VALVE.
 E.G.: ENCA4 KUC/TQ BECOMES ENCA4 KLC/TQ (SEE ON PAGE 2.59 FOR THE MISSING DIMENSIONS) *THE TYPES OF THE SOLENOID VALVES DO NOT INCLUDE COILS

"NAMUR" PORT PATTERN - 5 PORT MONOSTABLE

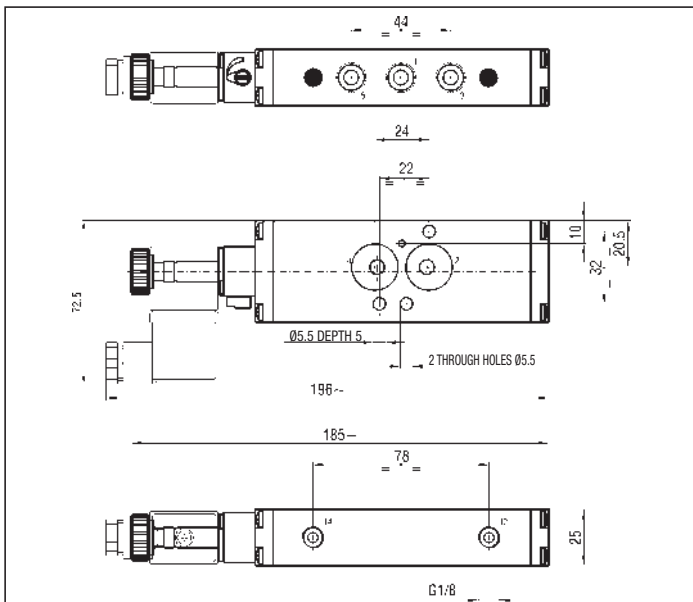

"NAMUR" PORT PATTERN - 5 PORT AND 3 POSITION BISTABLE

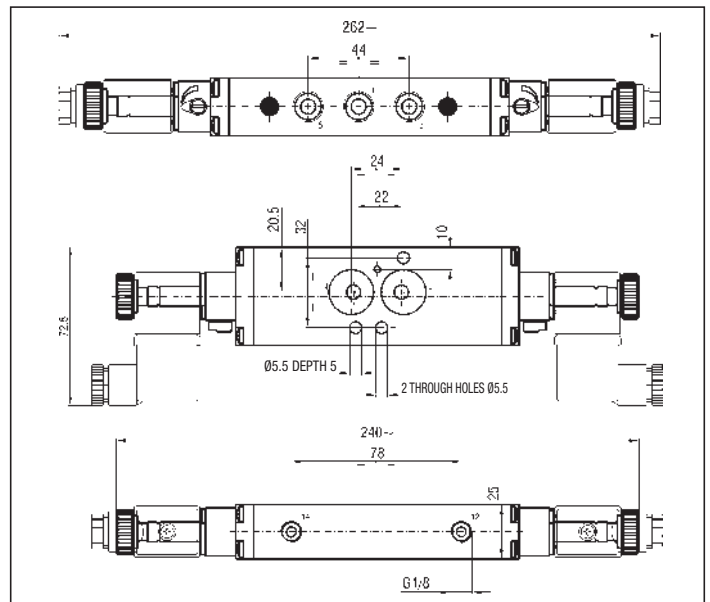

BASE FOR MANIFOLD MOUNTING OF VALVES G 1/4 - KB/EK4

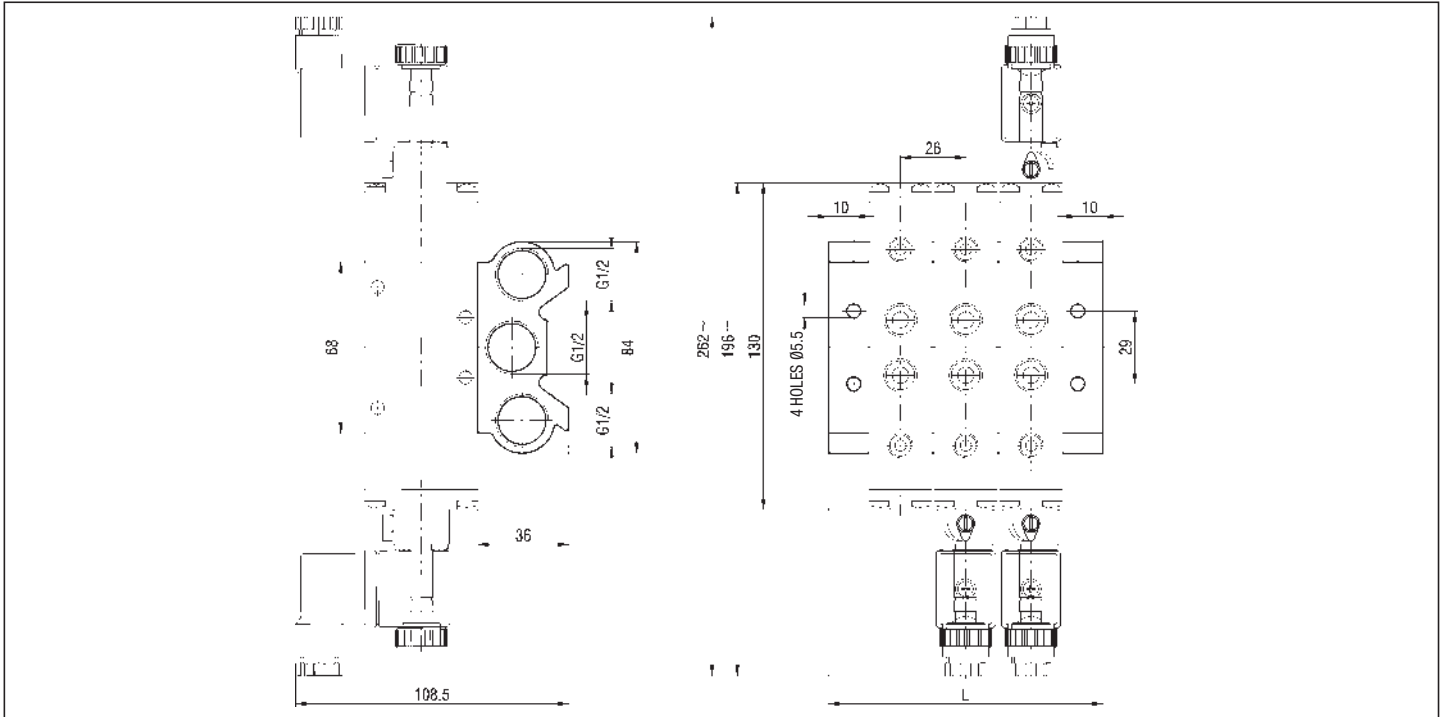

No. of stations	2	3	4	5	6	8	10	12	14	16	18	20
L	83	109	135	161	187	239	291	343	395	447	499	551
Weight (g)	460	590	720	850	980	1240	1500	1760	2020	2280	2540	2800
TYPE*	KB/EK4/2	KB/EK4/3	KB/EK4/4	KB/EK4/5	KB/EK4/6	KB/EK4/8	KB/EK4/10	KB/EK4/12	KB/EK4/14	KB/EK4/16	KB/EK4/18	KB/EK4/20

* BASES ARE SUPPLIED COMPLETE WITH NOTCH SCREWS AND SEALS

SUPPLY RAIL FOR MANIFOLD MOUNTING OF VALVES G 1/4 - CEK4

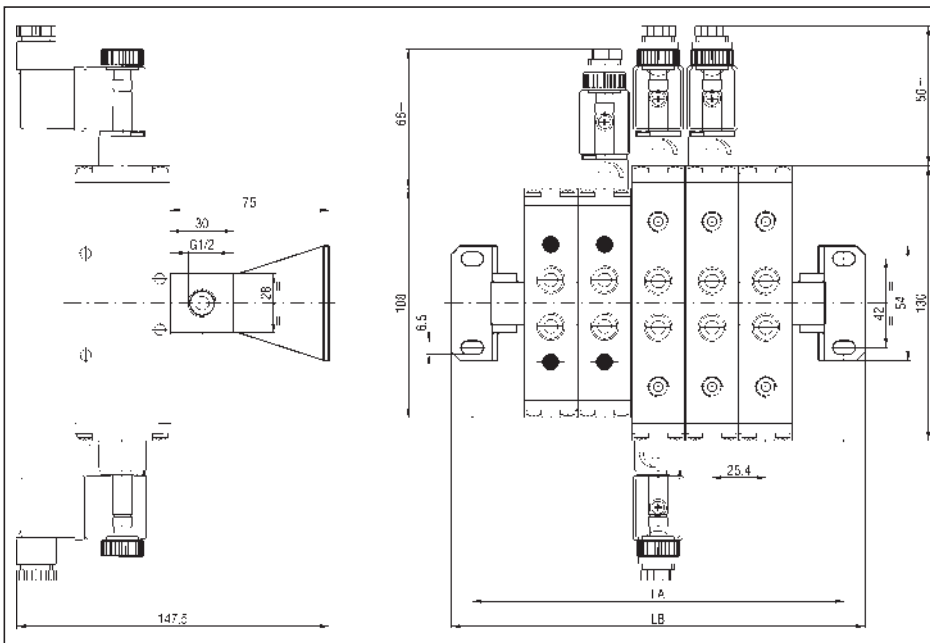

No. of stations	2	3	5
LA	99	125	176
LB	119	145	196
Weight (g)	310	390	550
TYPE*	CEK4/2	CEK4/3	CEK4/5

* SUPPLY RAILS ARE SUPPLIED COMPLETE WITH NOTCH SCREWS, SEALS AND FIXING BRACKETS

BLANKING PLATE - KIT/PC/EK4

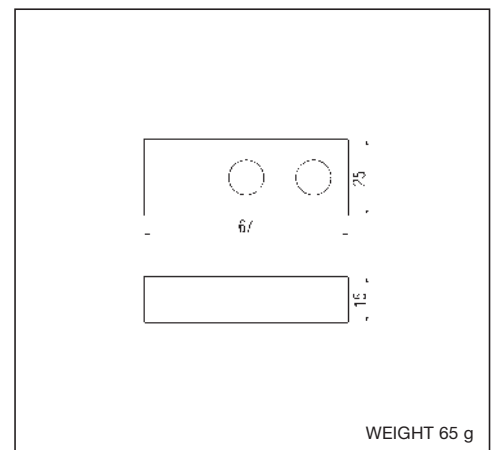

WEIGHT 65 g

2

PILOT ACTUATED VALVES G 1/2 - 3 PORT

Symbol	Function	Controls		Response time at 6 bar (ms)		Flow rate at 6 bar $\Delta P = 1$ bar (l/min)	Weight (g)	TYPE
		Pilot	Return	Energized	De-energized			
	3/2 N.O. monostable	Pneumatic	Mechanical spring	21	27	2400	770	EKA2 KR/ZR
	3/2 N.O. monostable	Pneumatic	Mechanical spring	21	27	2400	760	EKA2 KR/TQ
	3/2 N.C. monostable	Pneumatic	Mechanical spring	21	27	2200	770	EKC2 KR/ZR
	3/2 N.C. monostable	Pneumatic	Mechanical spring	21	27	2200	760	EKC2 KR/TQ
	3/2 bistable	Pneumatic	Pneumatic	20	20	2200	790	EK2 KR/KR

SOLENOID ACTUATED VALVES G 1/2 - 5 PORT

Symbol	Function	Controls		Response time at 6 bar (ms)		Flow rate at 6 bar $\Delta P = 1$ bar (l/min)	Weight (g)	TYPE
		Pilot	Return	Energized	De-energized			
	5/2 monostable	Solenoid	Mechanical spring	21	27	2800	1010	EKCA2 KR/ZR
		Solenoid	Pneumatic spring	21	27	2800	1000	EKCA2 KR/TQ
	5/2 bistable	Solenoid	Solenoid	20	20	2800	1000	EKCA2 KR/KR
	5/3 closed centre	Solenoid	Mechanical spring	20	25	1700	1020	EKCA2 SR/SR

3 PORT BISTABLE

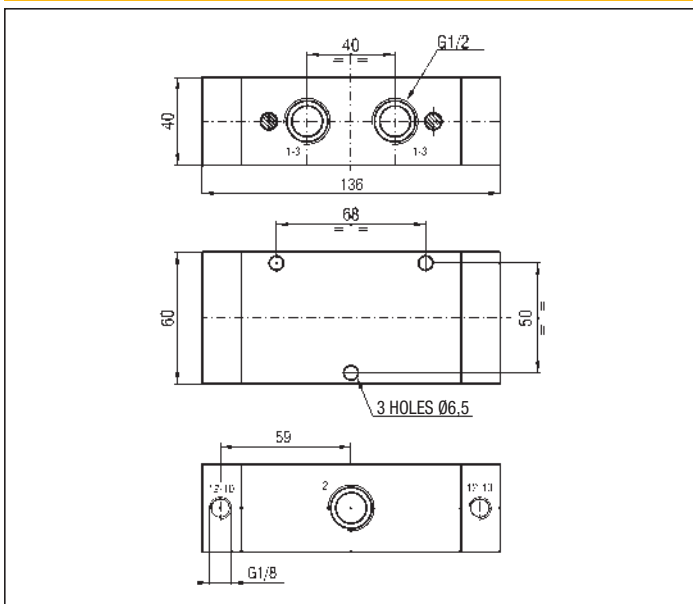

5 PORT BISTABLE

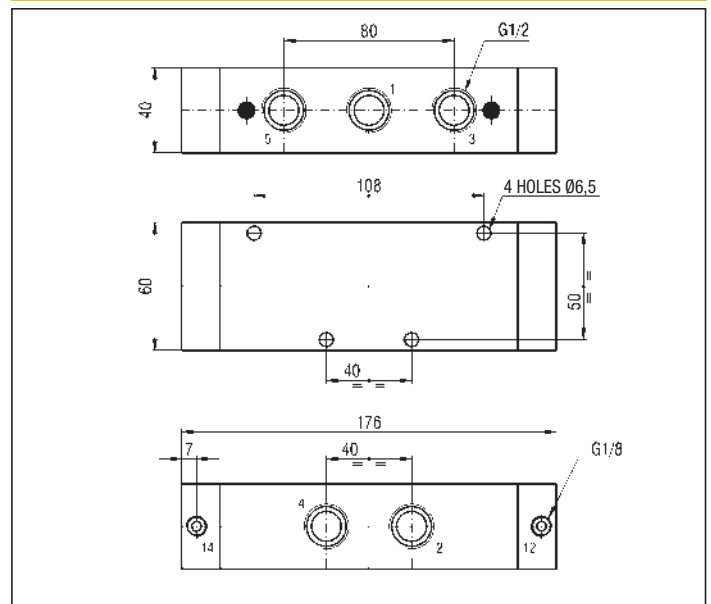

SOLENOID ACTUATED VALVES G 1/2 - 3 PORT

Symbol	Function	Controls		Response time at 6 bar (ms)		Flow rate at 6 bar $\Delta P = 1 \text{ bar}$ (NI/min)	Weight (g)	TYPE*
		Pilot	Return	Energized	De-energized			
	3/2 N.O. monostable	Solenoid	Mechanical spring	30	90	2400	800	EKA2 KUC/ZR
		Solenoid pilot assisted	Mechanical spring	30	90	2400	800	EKA2 KUR/ZR
		Solenoid	Mechanical spring	30	90	2400	790	EKA2 KUC/TQ
	3/2 N.C. monostable	Solenoid	Mechanical spring	30	90	2200	800	EKC2 KUC/ZR
		Solenoid pilot assisted	Mechanical spring	30	90	2200	800	EKC2 KUR/ZR
		Solenoid	Mechanical spring	30	90	2200	790	EKC2 KUC/TQ
	3/2 bistable	Solenoid	Solenoid	25	25	2200	850	EK2 KUC/KUC
		Solenoid pilot assisted	Solenoid pilot assisted	25	25	2200	850	EK2 KUR/KUR

P.S.: SUBSTITUTE THE LETTER "U" WITH THE LETTER "L" IN EACH SOLENOID CONTROL TYPE TO ORDER THE SOLENOID ACTUATED VALVES WITH SOLENOID AT 90° RESPECT THE BODY OF THE VALVE.

E.G.: EKA2 KUC/TQ BECOMES EKA2 KLC/TQ (SEE ON PAGE 2.59 FOR THE MISSING DIMENSIONS)

*THE TYPES OF THE SOLENOID VALVES DO NOT INCLUDE COILS

3 PORT MONOSTABLE

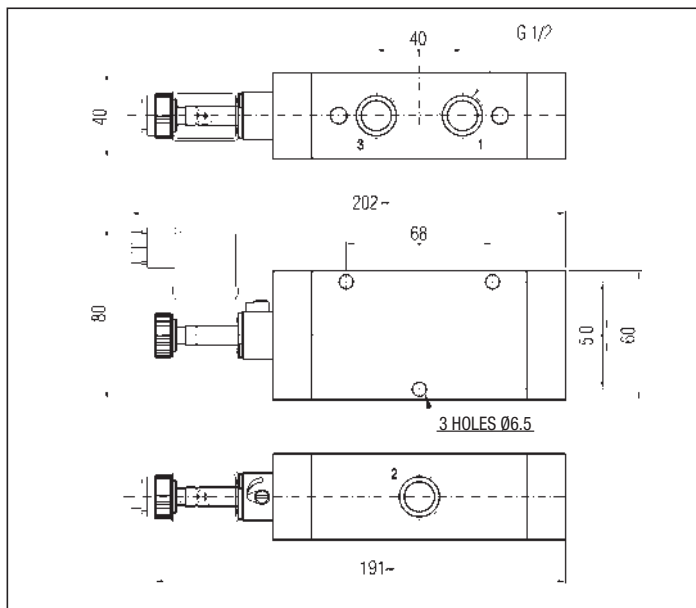

3 PORT BISTABLE

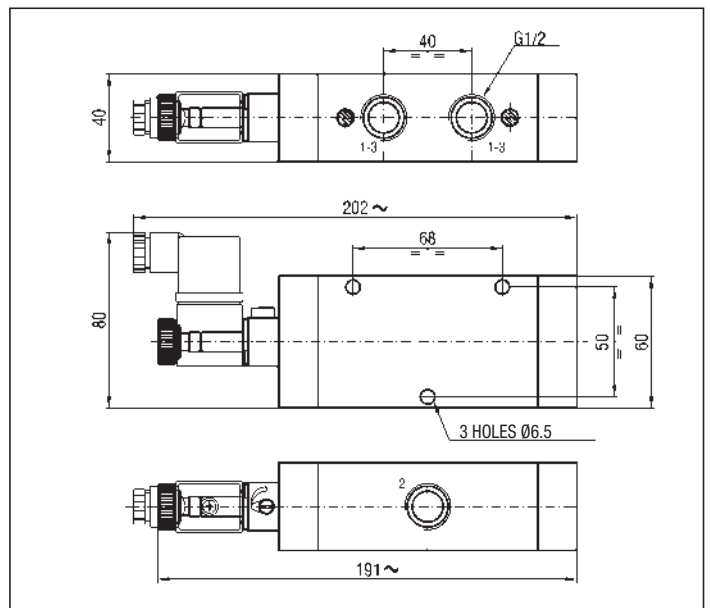

2

SOLENOID ACTUATED VALVES G 1/2 - 5 PORT

Symbol	Function	Controls		Response time at 6 bar (ms)		Flow rate at 6 bar $\Delta P = 1 \text{ bar (l/min)}$	Weight (g)	TYPE*
		Pilot	Return	Energized	De-energized			
	5/2 monostable	Solenoid	Mechanical spring	30	90	2800	1025	EKCA2 KUC/ZR
		Solenoid	Pneumatic spring	30	90	2800	1015	EKCA2 KUC/TQ
		Solenoid pilot assisted	Mechanical spring	30	90	2800	1025	EKCA2 KUR/ZR
	5/2 bistable	Solenoid	Solenoid	25	25	2800	1075	EKCA2 KUC/KUC
		Solenoid pilot assisted	Solenoid pilot assisted	25	25	2800	1075	EKCA2 KUR/KUR
	5/3 closed centre	Solenoid	Mechanical spring	25	80	1700	1085	EKCA2 SUC/SUC
		Solenoid pilot assisted	Mechanical spring	25	80	1700	1085	EKCA2 SUR/SUR

P.S.: SUBSTITUTE THE LETTER "U" WITH THE LETTER "L" IN EACH SOLENOID CONTROL TYPE TO ORDER THE SOLENOID ACTUATED VALVES WITH SOLENOID AT 90° RESPECT THE BODY OF THE VALVE.

E.G.: EKCA2 KUC/TQ BECOMES EKCA2 KLC/TQ (SEE ON PAGE 2.59 FOR THE MISSING DIMENSIONS)

*THE TYPES OF THE SOLENOID VALVES DO NOT INCLUDE COILS

5 VIE MONOSTABLE

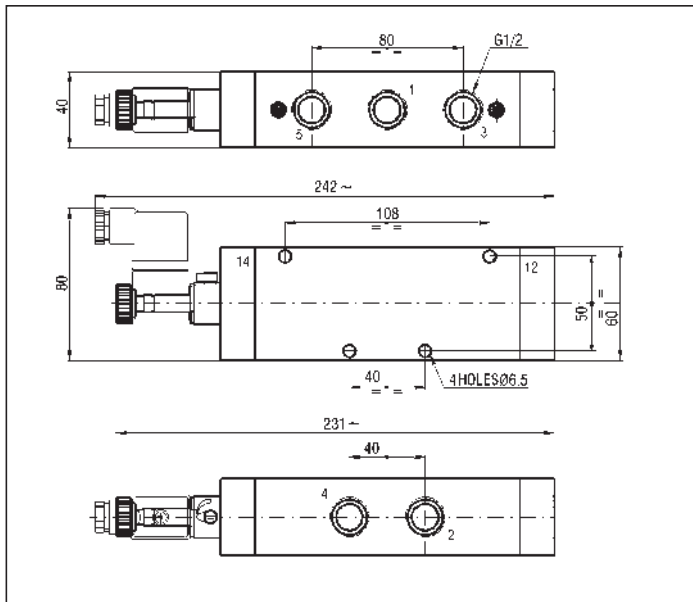

5 VIE BISTABLE

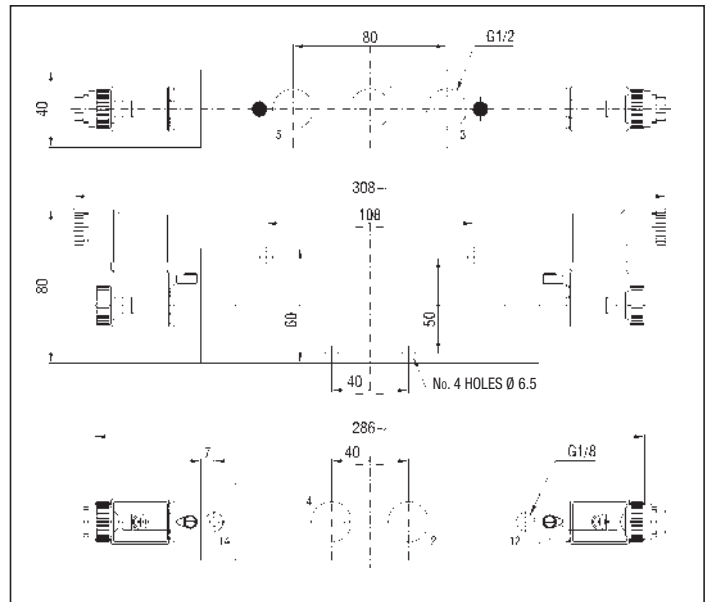

SOLENOID ACTUATED VALVES WITH SOLENOID AT 90°

SUBSTITUTE THE LETTER "U" WITH THE LETTER "L" IN EACH SOLENOID CONTROL TYPE TO ORDER THE SOLENOID ACTUATED VALVES WITH SOLENOID AT 90° RESPECT THE BODY OF THE VALVE. E.G.: EKCA2 KUC/TQ BECOMES EKCA2 KLC/TQ

G 1/8

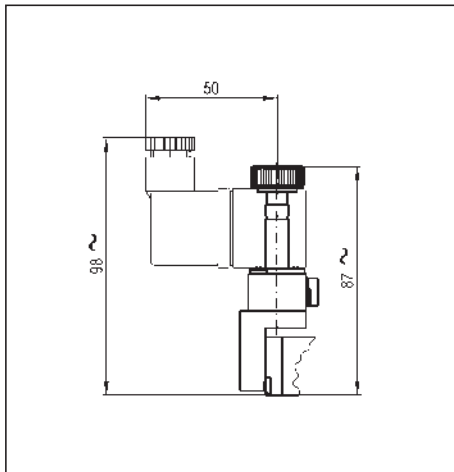

G 1/4

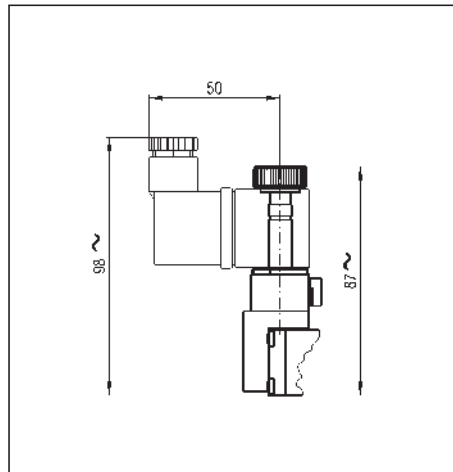

G 1/2

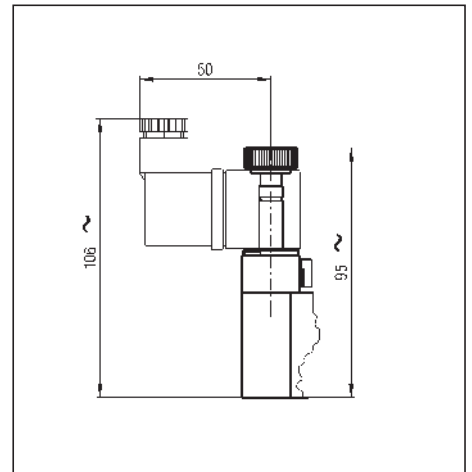

2

ACCESSORIES

MOUNTING BRACKET FOR PILOT AND SOLENOID ACTUATED VALVES TYPES EK 4 - EK 8 ON CYLINDER SERIES "CPU1"
(see from page 1.25)

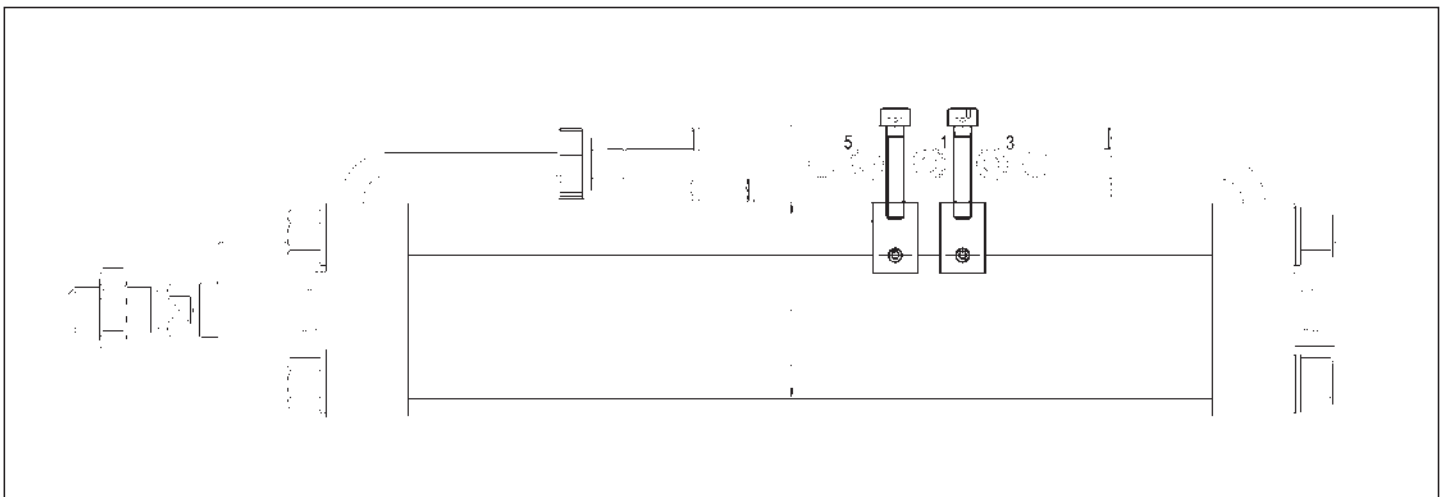

Ø CYLINDER	L	TYPE*
32	50,5	SQ32-40/EK
40	57,5	
50	69	SQ50-63/EK
63	79,5	
80	95,5	SQ80-100/EK
100	113	

* BRACKETS ARE SUPPLIED COMPLETE WITH DOWELS AND SCREWS

P.S.: PLEASE CHECK BEFORE ORDERING THE COUPLED DIMENSIONS OF THE CYLINDER WITH THE VALVE

DESCRIPTION

Valves series "UK" are produced in the 2/2, 3/2 and 5/2 monostable pneumatic functions. In the 3 port solenoid control version with small pilot system, sizes G 1/8 and G 1/4, support the 15 mm direct acting solenoid valve (type UMCSV with fixed position). All the other electric versions can support the 32 mm direct acting solenoid valve, type ULCSV/R (with fixed position), type C/USCSVG with sleeve \varnothing 9 mm (with fixed position and rotatable coils series USB and USBG) or the amplifier valve XVF4 for a sensible pneumatic piloting (see page 3.36). The 3/2 N.C. pilot actuated valves can also be used to switch vacuum thanks to a suitably reinforced spring.

The poppet design assures high flow and high life. This series of valves, in the sizes G 1/8, G 1/4 and G 1/2, is prearranged for base mounting with conveyed inlet by means of rear notch screws.

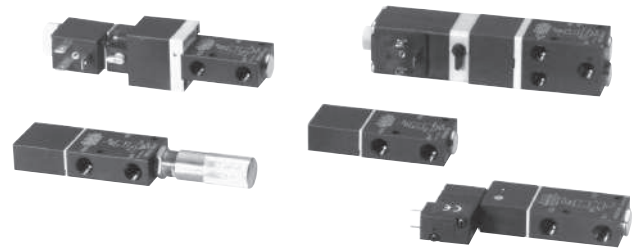

TECHNICAL DATA

Operating pressure	Solenoid actuated: $1,5 \div 10$ bar Pilot actuated: $1,5 \div 12$ bar
Working temperature	$0 \div +70$ °C (-20 °C with dry air)
Fluid	Filtered, unlubricated or lubricated compressed air - vacuum
Port size	G 1/8 - G 1/4 - G 1/2 - G 1
Pneumatic piloting port size	G 1/8
Nominal diameter	G 1/8 = 6 mm; G 1/4 = 8,5 mm; G 1/2 = 12 mm; G 1 = 23 mm
Piloting solenoid valves	UMCSV - see chapter Direct acting solenoid valves on page 2.3 ULCSV/R - see chapter Direct acting solenoid valves on page 2.6 C/USCSVG - see chapter Direct acting solenoid valves on page 2.13
Pneumatic piloting valve	XVF4 - see chapter Complementary valves on page 3.37
Coils (only for C/USCSVG)	USB - see chapter Coils on page 2.14 USBG - see chapter Coils on page 2.14
Electric connectors	USR 102/N9 - see chapter Connectors on page 2.15 ULR1B - see chapter Connectors on page 2.15 MEK 192/N - see chapter Connectors on page 2.15

MATERIALS

Control rod	Hardened and nickel-plated steel
Body	Anodized aluminium alloy
Springs	Stainless steel
Seals	NBR rubber
Bush rod	Brass
Piston	Acetal resin
Terminal strip	Acetal resin
Washer	Brass
End plug	Nickel-plated brass
Clamping screws	Steel

PILOTING CHART - UK G 1/8

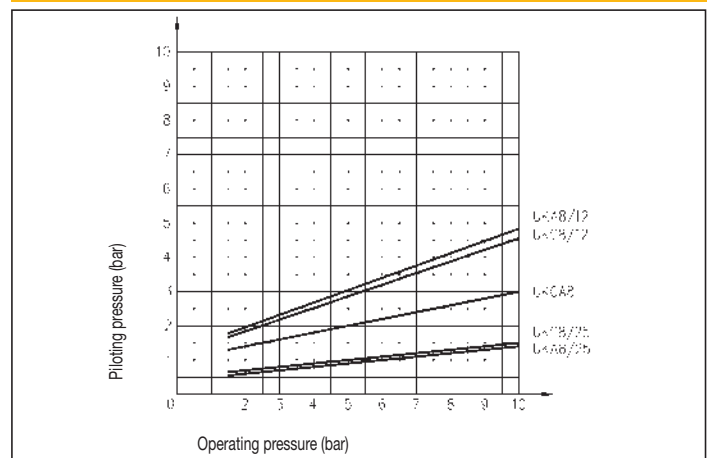

FLOW CHART - UK G 1/8 - 5/2

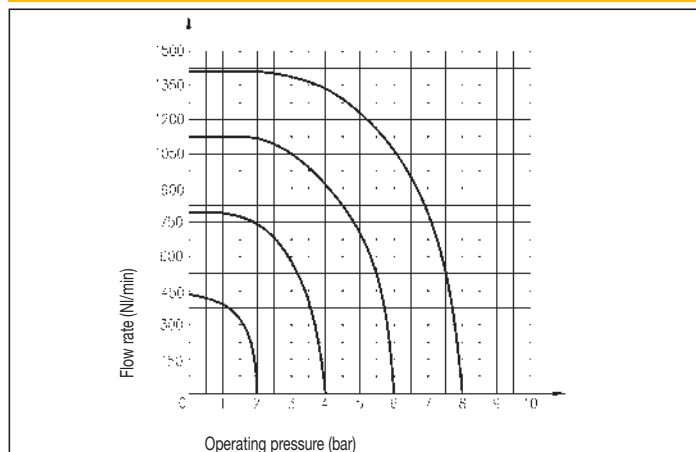

PILOTING CHART - UK G 1/4

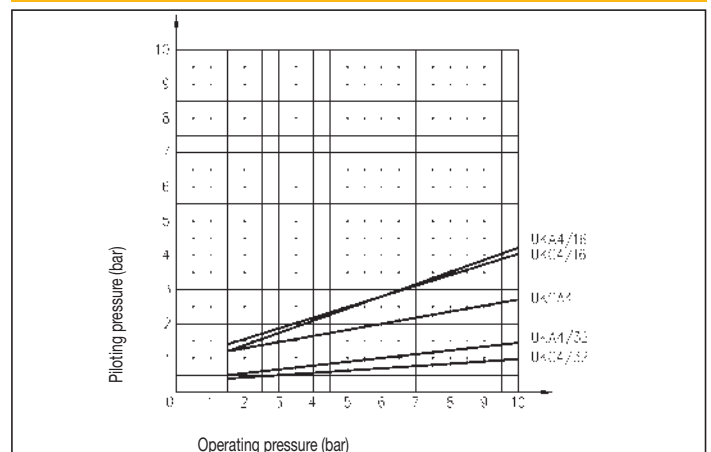

FLOW CHART - UK G 1/4 - 5/2

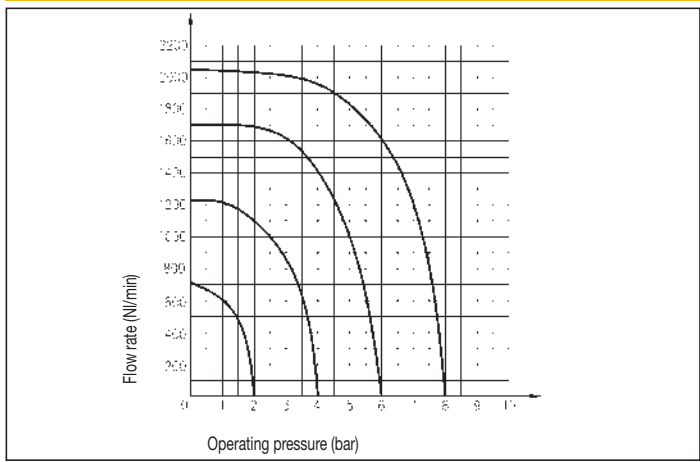

PILOTING CHART - UK G 1/2

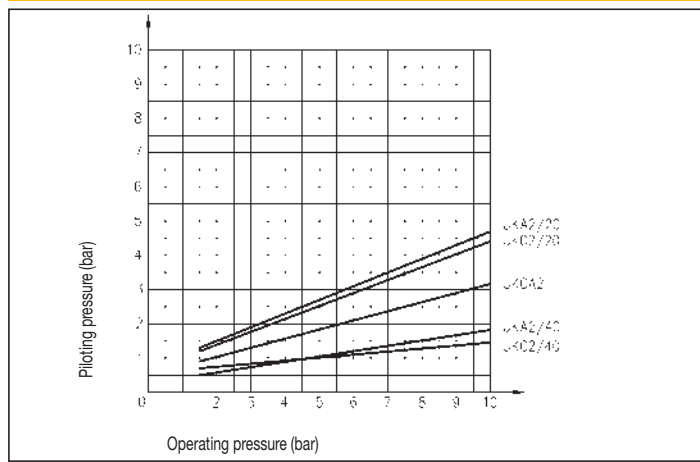

FLOW CHART UK - G 1/2 - 5/2

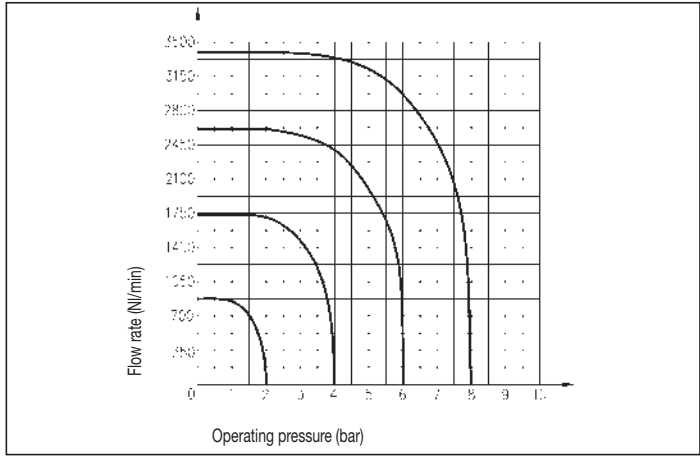

PILOTING CHART - UK G 1

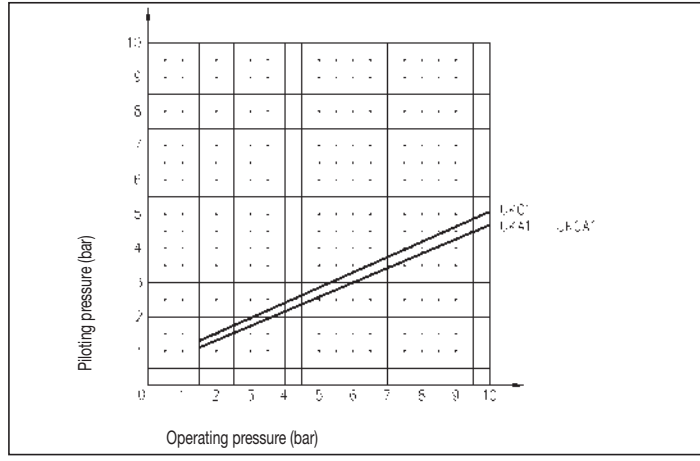

FLOW CHART - UK G 1 - 5/2

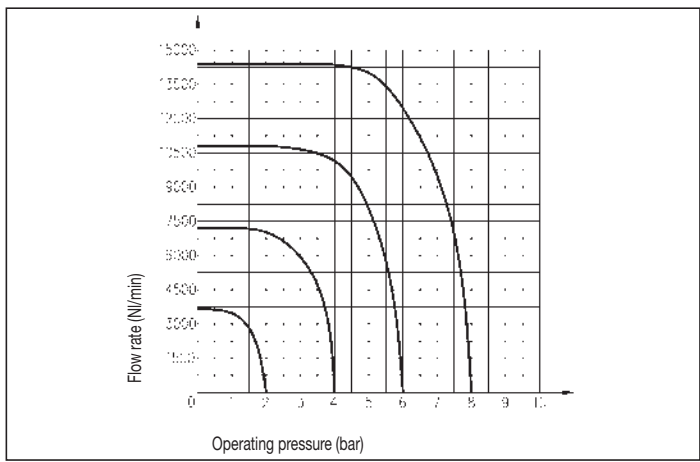

SPARE PARTS

SEALS KIT	
3/2 N.O. G 1/8 small pilot system	UKA/12/SG/8
3/2 N.C. G 1/8 small pilot system	UKC/12/SG/8
3/2 N.O. G 1/8 big pilot system	UKA/25/SG/8
3/2 N.C. G 1/8 big pilot system	UKC/25/SG/8
5/2 G 1/8	UKCA/SG/8
3/2 N.O. G 1/4 small pilot system	UKA/16/SG/4
3/2 N.C. G 1/4 small pilot system	UKC/16/SG/4
3/2 N.O. G 1/4 big pilot system	UKA/32/SG/4
3/2 N.C. G 1/4 big pilot system	UKC/32/SG/4
5/2 G 1/4	UKCA/SG/4
3/2 N.O. G 1/2 small pilot system	UKA/20/SG/2
3/2 N.C. G 1/2 small pilot system	UKC/20/SG/2
3/2 N.O. G 1/2 big pilot system	UKA/40/SG/2
3/2 N.C. G 1/2 big pilot system	UKC/40/SG/2
5/2 G 1/2	UKCA/SG/2
3/2 N.O. G 1	UKA/SG/1
3/2 N.C. G 1	UKC/SG/1

2

PILOT ACTUATED VALVES* G 1/8 - 2, 3 and 5 PORT

Symbol	Function	Controls		Response time at 6 bar (ms)		Flow rate at 6 bar $\Delta P = 1 \text{ bar (NI/min)}$	Weight (g)	TYPE*
		Pilot	Return	Energized	De-energized			
	3/2 N.O. monostable	Small pneumatic	Mechanical spring	18	34	700	115	UKA 8/12
	3/2 N.C. monostable	Small pneumatic	Mechanical spring	20	29	700	115	UKC 8/12
		Servo fed small pneumatic	Mechanical spring	20	29	700	115	UKC 8/12/SA
		Adjustable small pneumatic	Mechanical spring	-	-	700	180	UKC 8/12/T
	3/2 N.O. monostable	Big pneumatic	Mechanical spring	18	38	700	135	UKA 8/25
	3/2 N.C. monostable	Big pneumatic	Mechanical spring	18	38	700	135	UKC 8/25**
		Servo fed big pneumatic	Mechanical spring	18	38	700	135	UKC 8/25/SA
		Adjustable big pneumatic	Mechanical spring	-	-	700	200	UKC 8/25/T
	5/2 monostable	Pneumatic	Mechanical spring	19	40	650	195	UKCA8
		Servo fed pneumatic	Mechanical spring	19	40	650	195	UKCA8/SA

* FOR THE PILOT ACTUATED VALVES OBTAINABLE WITH XVF4 SEE THE TABLE SOLENOID ACTUATED VALVES ON PAGE 2.64

** IF THE TYPE INCLUDES THE SUFFIX "/MR," THIS VALVE CAN BE USED TO SWITCH VACUUM

P.S.: ADD AT THE TYPE OF THE VALVES 3/2 THE LETTER "H" BETWEEN THE LETTERS "K" AND "A" (OR "C") TO ORDER 2/2 N.O. (OR 2/2 N.C.) VALVES.

E.G.: UKHA 8/12; UKHC 8/25

3 PORT SMALL PNEUMATIC

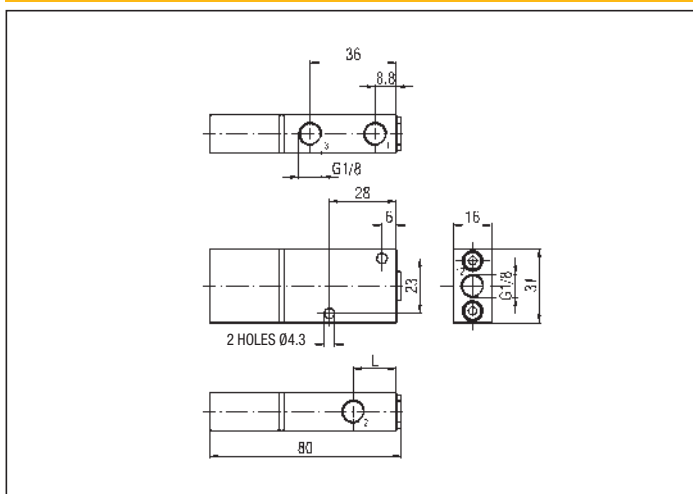

FUNCTION	L
3/2 N.O.	23
3/2 N.C.	18

3 PORT BIG PNEUMATIC

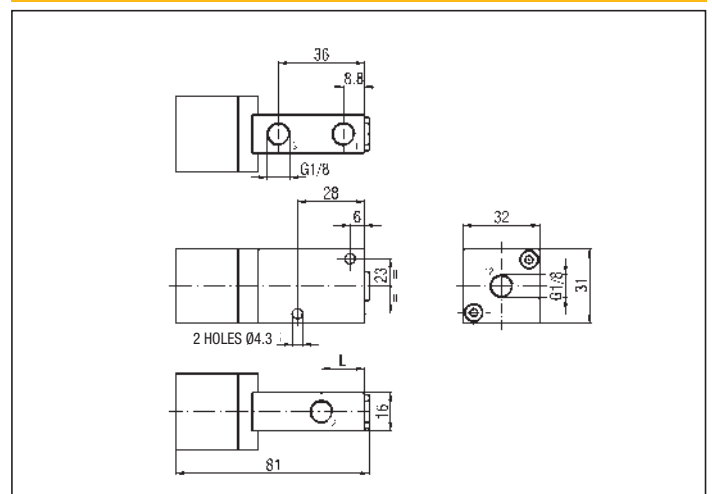

UKC 8/12/T

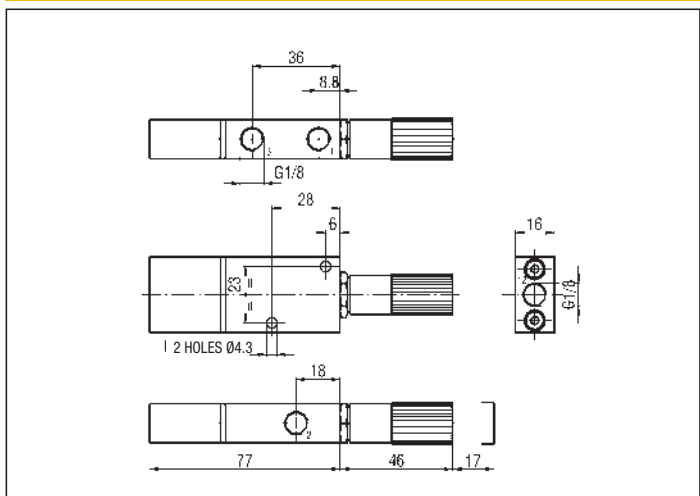

UKC 8/25/T

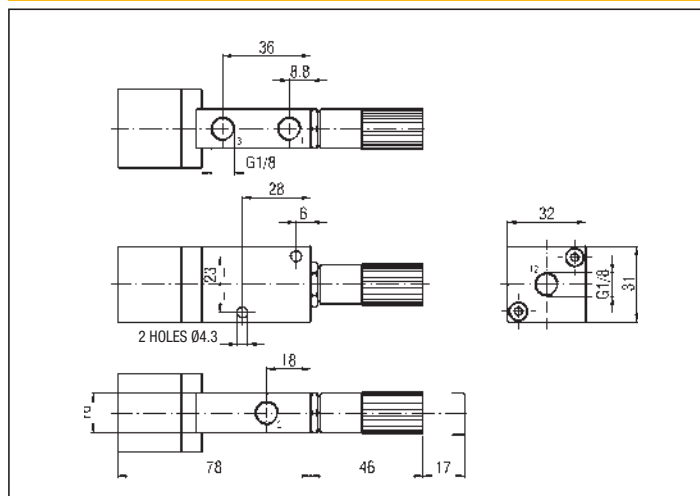

SPRING CALIBRATION UKC8/12/T

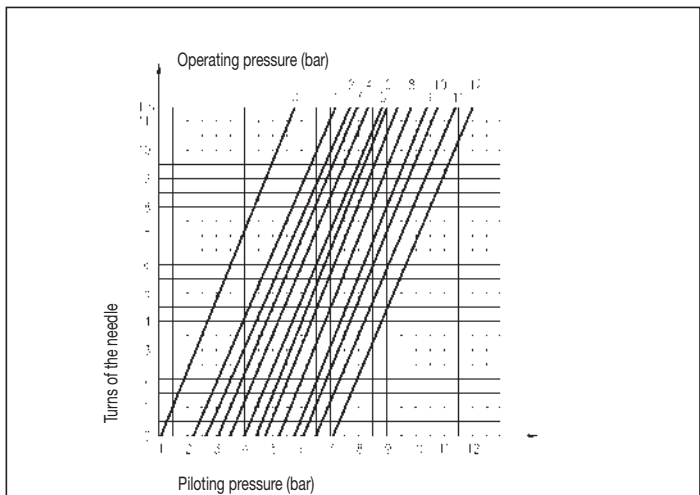

SPRING CALIBRATION UKC8/25/T

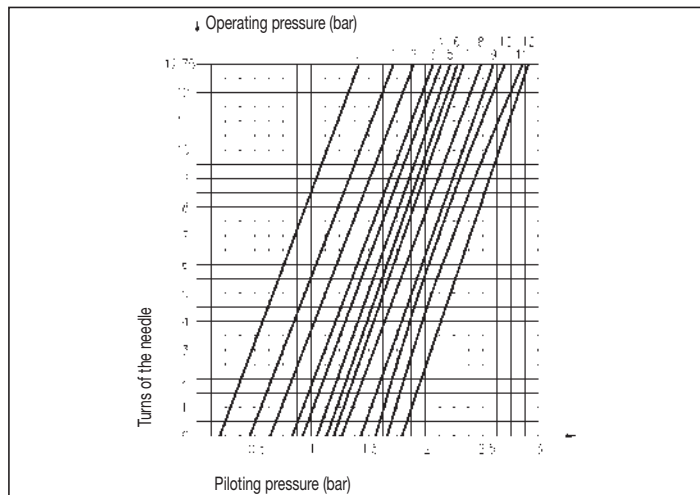

5 PORT

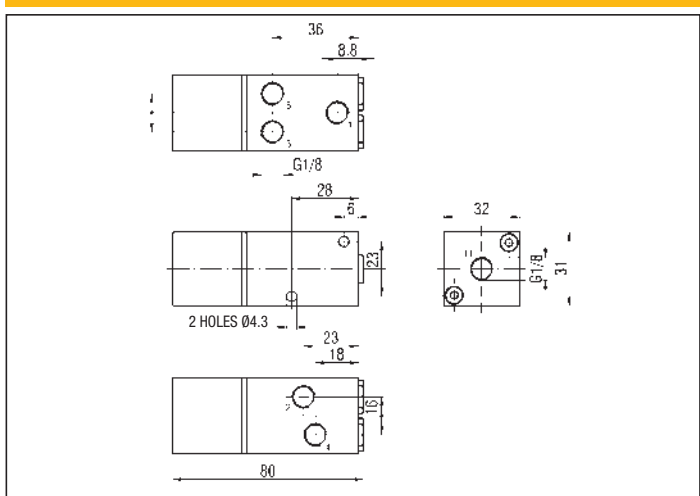

5 PORT WITH XV4

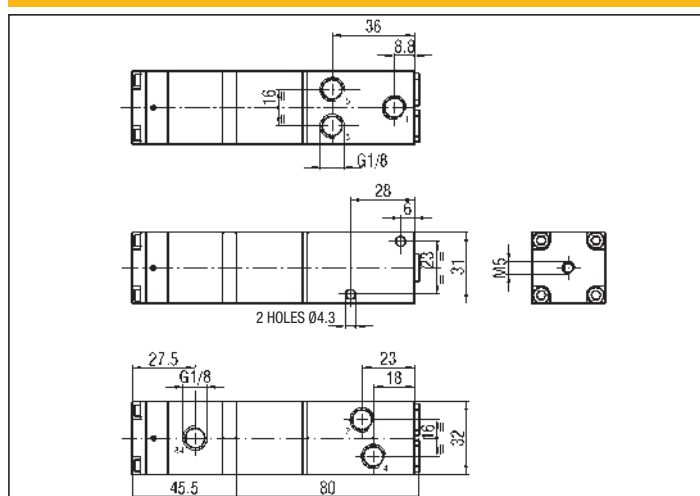

SOLENOID ACTUATED VALVES G 1/8 - 2, 3 and 5 PORT

Symbol	Function	Controls		Response time at 6 bar (ms)		Flow rate at 6 bar $\Delta P = 1$ bar (NI/min)	Weight (g)	type
		Pilot	Return	Energized	De-energized			
	3/2 N.O. monostable	Small solenoid	Mechanical spring	10	28	700	108	UKA 8/12/U*
	3/2 N.C. monostable	Small solenoid	Mechanical spring	10	28	700	108	UKC 8/12/U*
	3/2 N.O. monostable	Big solenoid	Mechanical spring	18	38	700	135	UKA 8/25/U**
	3/2 N.C. monostable	Big solenoid	Mechanical spring	18	38	700	135	UKC 8/25/U**
	5/2 monostable	Solenoid	Mechanical spring	19	40	650	203	UKCA 8/U**

* TYPES OF THESE SOLENOID VALVES INCLUDE THE PILOTING SOLENOID VALVES "UMCSV" - SEE ON PAGE 2.3 (SPECIFY THE VOLTAGE IN THE ORDER)

** TYPES OF THESE SOLENOID VALVES DO NOT INCLUDE THE PILOTING SOLENOID VALVES (SEE ON PAGE 2.6 FOR "ULCSV/R" AND ON PAGE 2.13 FOR "C/USCSVG")

WHEREAS USING AS PILOT THE VALVE "XVF4" THE RESULT IS A LOW PRESSURE PILOT ACTUATED VALVE (FOR "XVF4" - SEE ON PAGE 3.37)

PS.: ADD AT THE TYPE OF THE VALVES 3/2 THE LETTER "H" BETWEEN THE LETTERS "K" AND "A" (OR "C") TO ORDER 2/2 N.O. (OR 2/2 N.C.) VALVES.

E.G.: UKHA 8/12/U; UKHC 8/25/U

3 PORT SMALL SOLENOID

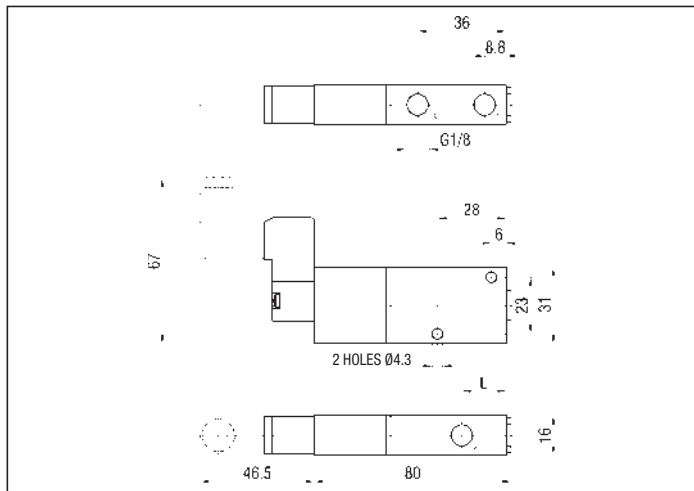

3 PORT BIG SOLENOID WITH ULCSV/R

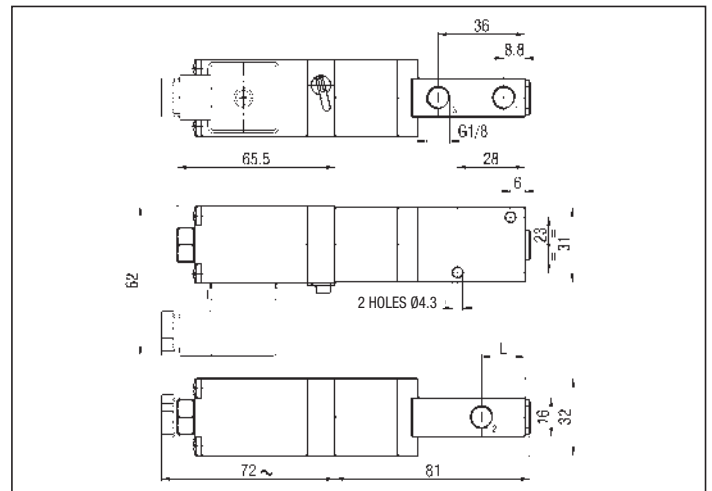

3 PORT BIG SOLENOID WITH C/USCSVG

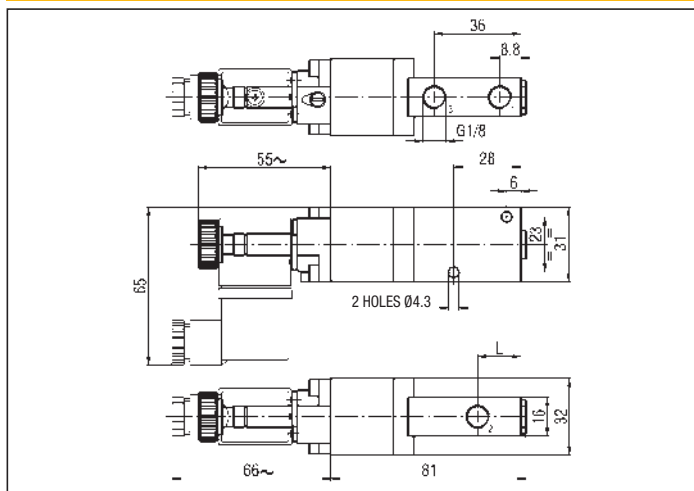

FUNCTION	L
3/2 N.O.	23
3/2 N.C.	18

5 PORT WITH ULCSV/R

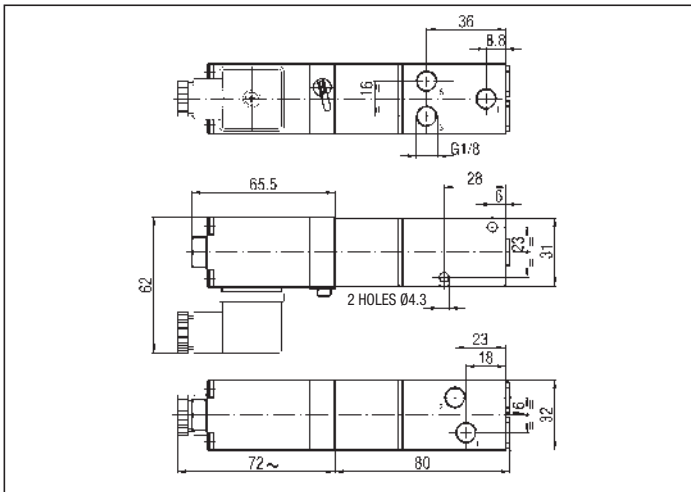

5 PORT WITH C/USCSVG

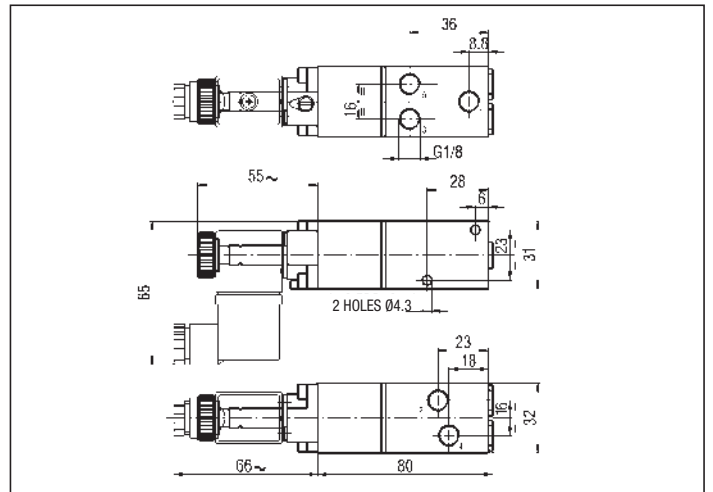

2

FIXED LENGTH BASE FOR MANIFOLD MOUNTING OF VALVES G 1/8 - CK8

No. of stations	2	3	5
L	86	119	183
Weight(g)	140	200	320
TYPE*	CK8/2	CK8/3	CK8/5

* FIXED LENGTH BASES ARE SUPPLIED COMPLETE WITH NOTCH SCREWS AND SEALS

2

PILOT ACTUATED VALVES* G 1/4 - 2, 3 and 5 PORT

Symbol	Function	Controls		Response time at 6 bar (ms)		Flow rate at 6 bar $\Delta P = 1 \text{ bar (Nl/min)}$	Weight (g)	TYPE
		Pilot	Return	Energized	De-energized			
	3/2 N.O. monostable	Small pneumatic	Mechanical spring	20	30	950	225	UKA 4/16
	3/2 N.C. monostable	Small pneumatic	Mechanical spring	20	30	1100	225	UKC 4/16
		Servo fed small pneumatic	Mechanical spring	16	30	1100	225	UKC 4/16/SA
	3/2 N.O. monostable	Big pneumatic	Mechanical spring	20	30	950	280	UKA 4/32
	3/2 N.C. monostable	Big pneumatic	Mechanical spring	20	30	1100	280	UKC 4/32**
		Servo fed big pneumatic	Mechanical spring	20	28	1100	280	UKC 4/32/SA
	5/2 monostable	Pneumatic	Mechanical spring	24	45	1000	415	UKCA 4
		Servo fed pneumatic	Mechanical spring	24	45	1000	415	UKCA 4/SA

* FOR THE PILOT ACTUATED VALVES OBTAINABLE WITH "XVF4" SEE THE TABLE SOLENOID ACTUATED VALVES ON PAGE 2.67

** IF THE TYPE INCLUDES THE SUFFIX "/MR," THIS VALVE CAN BE USED TO SWITCH VACUUM

P.S.: ADD AT THE TYPE OF THE VALVES 3/2 THE LETTER "H" BETWEEN THE LETTERS "K" AND "A" (OR "C") TO ORDER 2/2 N.O. (OR 2/2 N.C.) VALVES.

E.G.: UKHA 4/16; UKHC 4/32

3 PORT SMALL PNEUMATIC

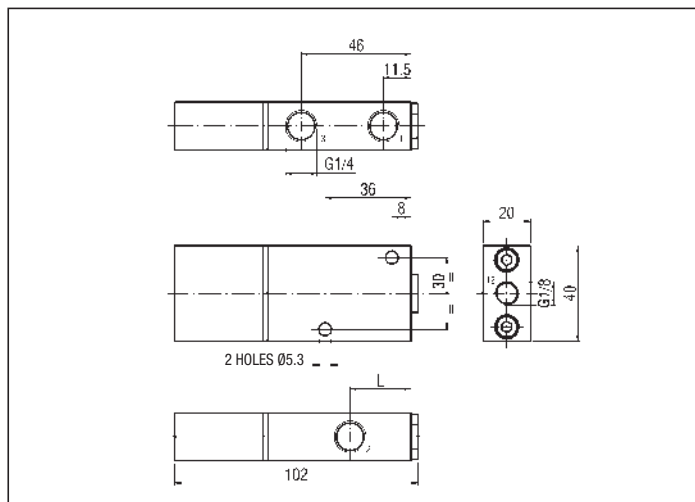

FUNCTION	L
3/2 N.O.	30
3/2 N.C.	25,5

3 PORT BIG PNEUMATIC

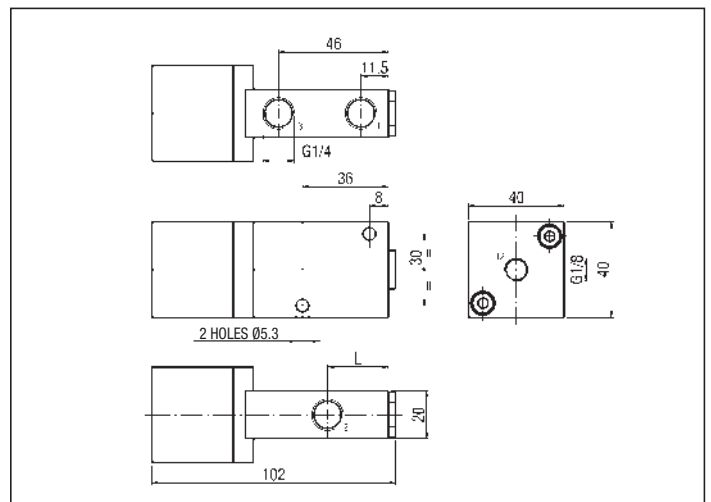

5 PORT

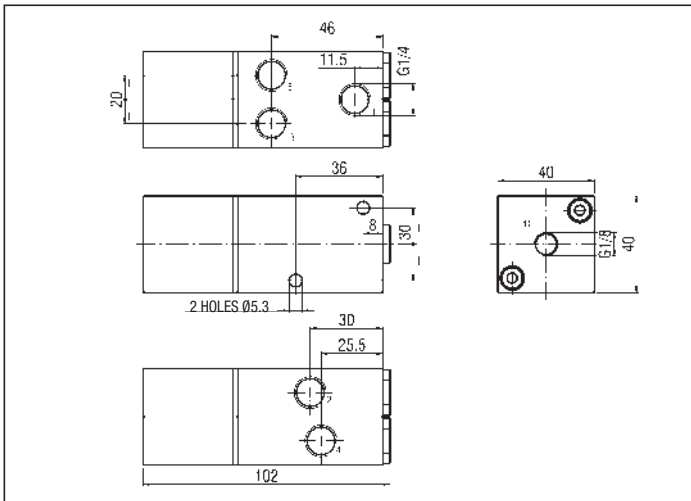

5 PORT WITH XVF4

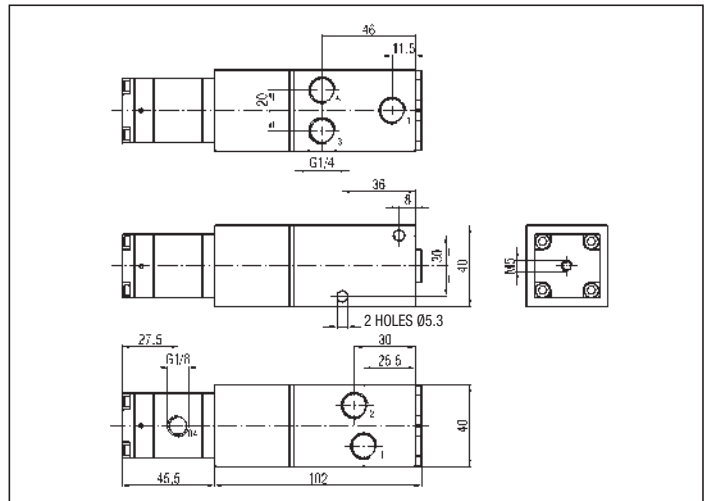

SOLENOID ACTUATED VALVES G 1/4 - 2, 3 and 5 PORT

Symbol	Function	Controls		Response time at 6 bar (ms)		Flow rate at 6 bar $\Delta P = 1 \text{ bar (Nl/min)}$	Weight (g)	TYPE
		Pilot	Return	Energized	De-energized			
	3/2 N.O. monostable	Small solenoid	Mechanical spring	10	28	950	225	UKA 4/16/U*
	3/2 N.C. monostable	Small solenoid	Mechanical spring	10	28	1100	230	UKC 4/16/U*
	3/2 N.O. monostable	Big solenoid	Mechanical spring	20	30	950	280	UKA 4/32/U**
	3/2 N.C. monostable	Big solenoid	Mechanical spring	20	30	1100	280	UKC 4/32/U**
	5/2 monostable	Solenoid	Mechanical spring	24	45	1000	415	UKCA 4/U**

* TYPES OF THESE SOLENOID VALVES INCLUDE THE PILOTING SOLENOID VALVES "UMCSV" - SEE ON PAGE 2.3 (SPECIFY THE VOLTAGE IN THE ORDER)

** TYPES OF THESE SOLENOID VALVES DO NOT INCLUDE THE PILOTING SOLENOID VALVES (SEE ON PAGE 2.6 FOR "ULCSV/R" AND ON PAGE 2.13 FOR "C/USCSVG")

WHEREAS USING AS PILOT THE VALVE "XVF4" THE RESULT IS A LOW PRESSURE PILOT ACTUATED VALVE (FOR "XVF4" - SEE ON PAGE 3.37)

PS.: ADD AT THE TYPE OF THE VALVES 3/2 THE LETTER "H" BETWEEN THE LETTERS "K" AND "A" (OR "C") TO ORDER 2/2 N.O. (OR 2/2 N.C.) VALVES.

E.G.: UKHA 4/16/U; UKHC 4/32/U

3 PORT SMALL SOLENOID

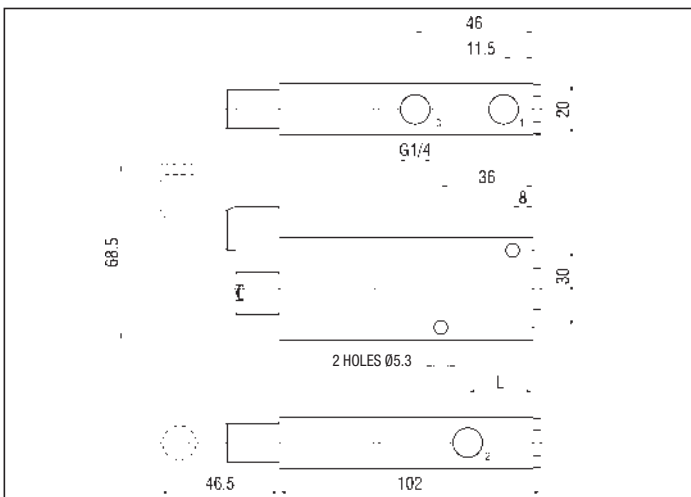

3 PORT BIG SOLENOID WITH ULCSV/R

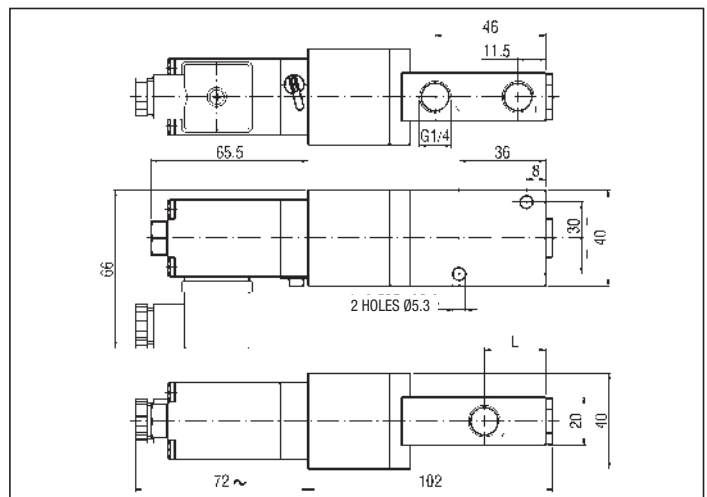

2

3 PORT BIG SOLENOID WITH C/USCSVG

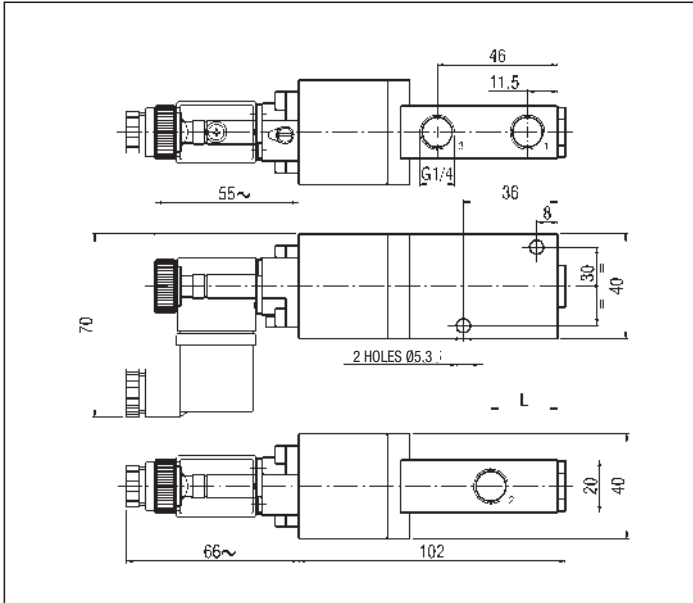

5 PORT WITH ULCSV/R

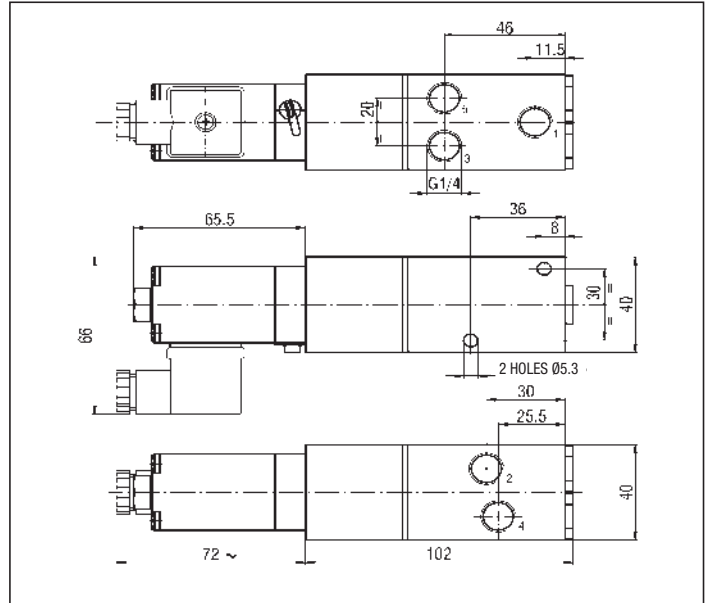

5 PORT WITH C/USCSVG

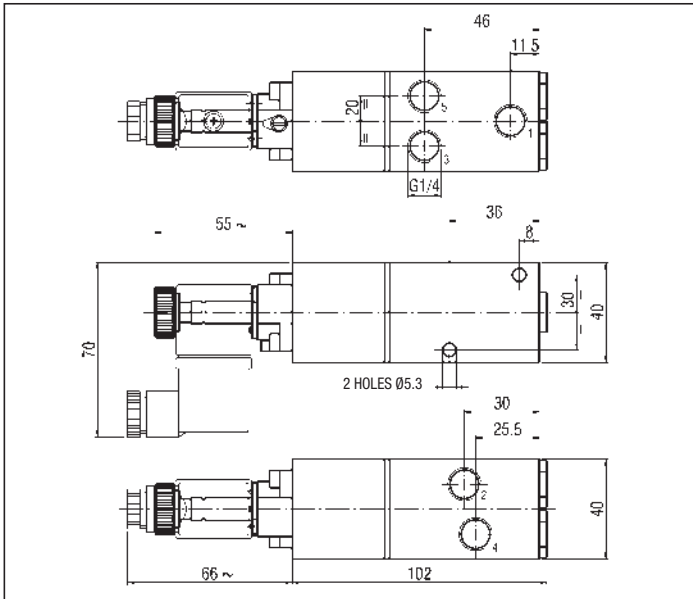

FUNCTION	L
3/2 N.O.	30
3/2 N.C.	25,5

FIXED LENGTH BASE FOR MANIFOLD MOUNTING OF VALVES G 1/4 - CK4

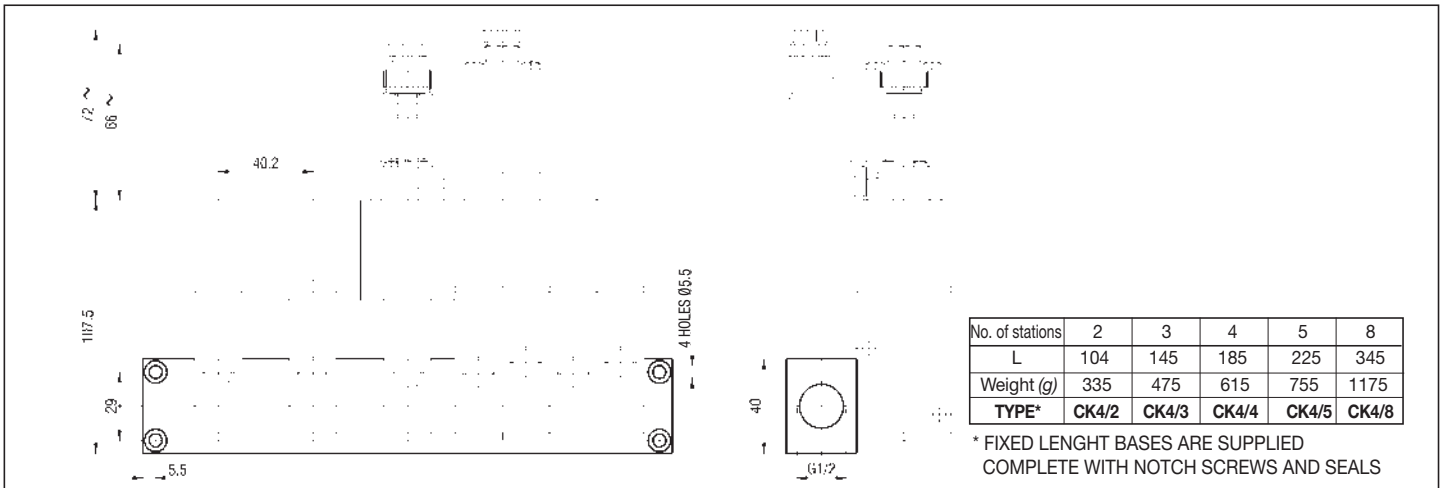

No. of stations	2	3	4	5	8
L	104	145	185	225	345
Weight (g)	335	475	615	755	1175
TYPE*	CK4/2	CK4/3	CK4/4	CK4/5	CK4/8

* FIXED LENGTH BASES ARE SUPPLIED COMPLETE WITH NOTCH SCREWS AND SEALS

PILOT ACTUATED VALVES* G 1/2 - 2, 3 and 5 PORT

Symbol	Function	Controls		Response time at 6 bar (ms)		Flow rate at 6 bar $\Delta P = 1 \text{ bar (Nl/min)}$	Weight (g)	TYPE
		Pilot	Return	Energized	De-energized			
	3/2 N.O. monostable	Small pneumatic	Mechanical spring	24	32	1900	420	UKA 2/20
	3/2 N.C. monostable	Small pneumatic	Mechanical spring	24	32	2100	420	UKC 2/20
		Servo fed small pneumatic	Mechanical spring	25	32	2100	520	UKC 2/20/SA
	3/2 N.O. monostable	Big pneumatic	Mechanical spring	24	32	1900	520	UKA 2/40
	3/2 N.C. monostable	Big pneumatic	Mechanical spring	24	32	2100	520	UKC 2/40**
		Servo fed big pneumatic	Mechanical spring	20	30	2100	520	UKC 2/40/SA
	5/2 monostable	Pneumatic	Mechanical spring	24	40	2000	800	UKCA 2
		Servo fed pneumatic	Mechanical spring	24	40	2000	800	UKCA 2/SA

* FOR THE PILOT ACTUATED VALVES OBTAINABLE WITH "XVF4" SEE THE TABLE SOLENOID ACTUATED VALVES ON PAGE 2.70

** IF THE TYPE INCLUDES THE SUFFIX "/MR," THIS VALVE CAN BE USED TO SWITCH VACUUM

P.S.: ADD AT THE TYPE OF THE VALVES 3/2 THE LETTER "H" BETWEEN THE LETTERS "K" AND "A" (OR "C") TO ORDER 2/2 N.O. (OR 2/2 N.C.) VALVES.

E.G.: UKHA 2/20; UKHC 2/20

3 PORT SMALL PNEUMATIC

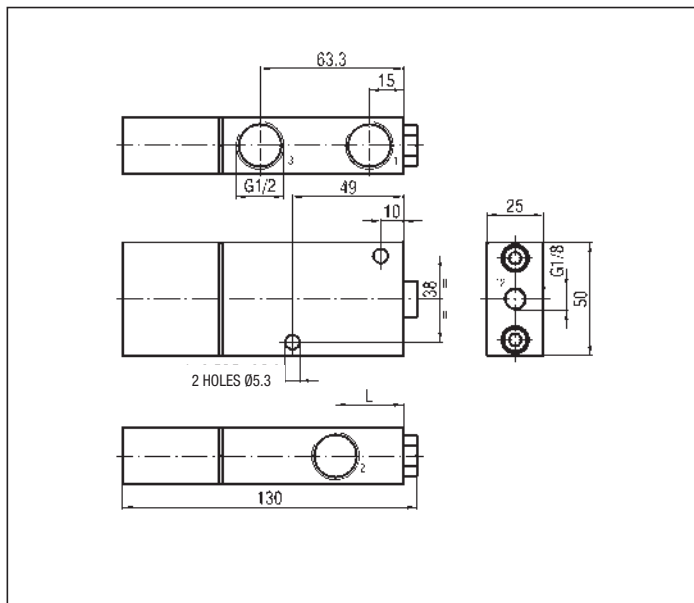

3 PORT BIG PNEUMATIC

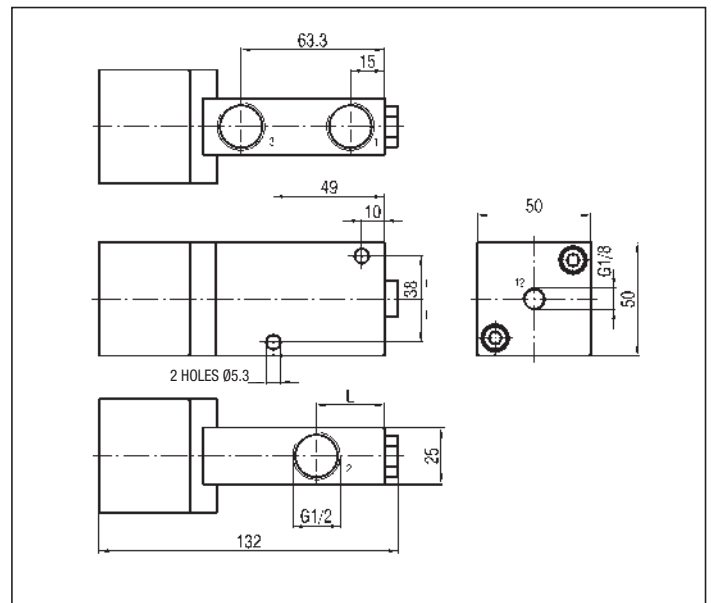

FUNCTION	L
3/2 N.O.	40
3/2 N.C.	30

5 PORT

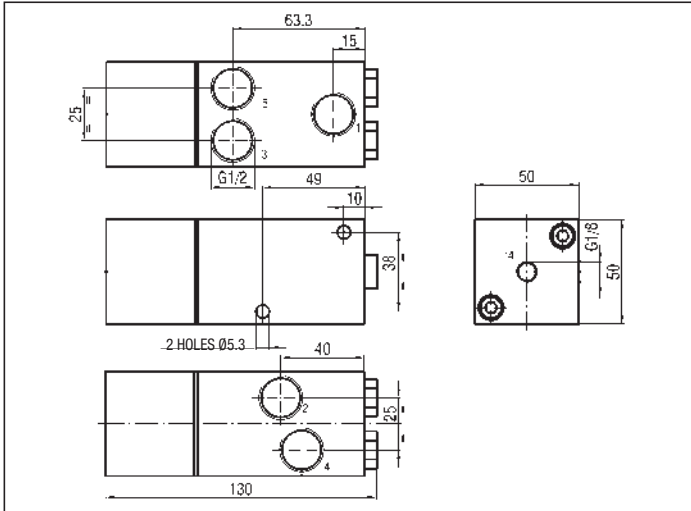

5 PORT WITH XVF4

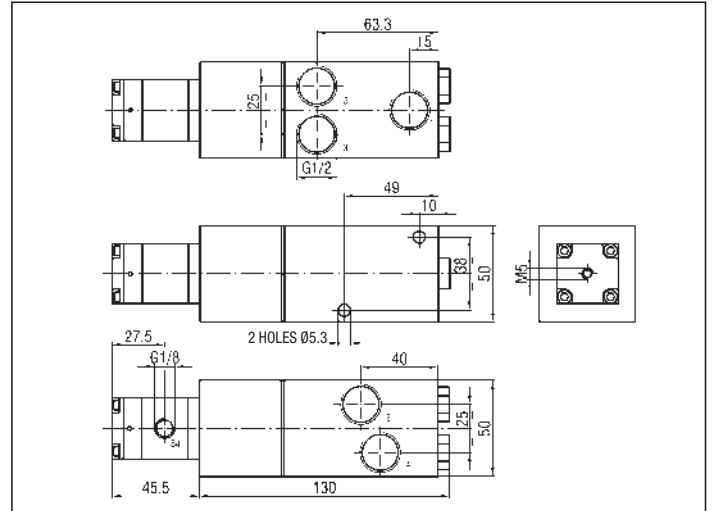

SOLENOID ACTUATED VALVES G 1/2 - 2, 3 and 5 PORT

Symbol	Function	Controls		Response time at 6 bar (ms)		Flow rate at 6 bar ΔP = 1 bar (NI/min)	Weight (g)	TYPE
		Pilot	Return	Energized	De-energized			
	3/2 N.O. monostable	Small solenoid	Mechanical spring	24	32	1900	430	UKA 2/20/U*
	3/2 N.C. monostable	Small solenoid	Mechanical spring	24	32	2100	440	UKC 2/20/U*
	3/2 N.O. monostable	Big solenoid	Mechanical spring	24	32	1900	530	UKA 2/40/U**
	3/2 N.C. monostable	Big solenoid	Mechanical spring	24	32	2100	540	UKC 2/40/U**
	5/2 monostable	Solenoid	Mechanical spring	24	32	2000	810	UKCA 2/U**

* TYPES OF THESE SOLENOID VALVES INCLUDE THE PILOTING SOLENOID VALVES "UMCSV" - SEE ON PAGE 2.3 (SPECIFY THE VOLTAGE IN THE ORDER)

** TYPES OF THESE SOLENOID VALVES DO NOT INCLUDE THE PILOTING SOLENOID VALVES (SEE ON PAGE 2.6 FOR "ULCSV/R" AND ON PAGE 2.13 FOR "C/USCSVG")

WHEREAS USING AS PILOT THE VALVE "XVF4" THE RESULT IS A LOW PRESSURE PILOT ACTUATED VALVE (FOR "XVF4" - SEE ON PAGE 3.37)

PS.: ADD AT THE TYPE OF THE VALVES 3/2 THE LETTER "H" BETWEEN THE LETTERS "K" AND "A" (OR "C") TO ORDER 2/2 N.O. (OR 2/2 N.C.) VALVES.

3 PORT SMALL SOLENOID

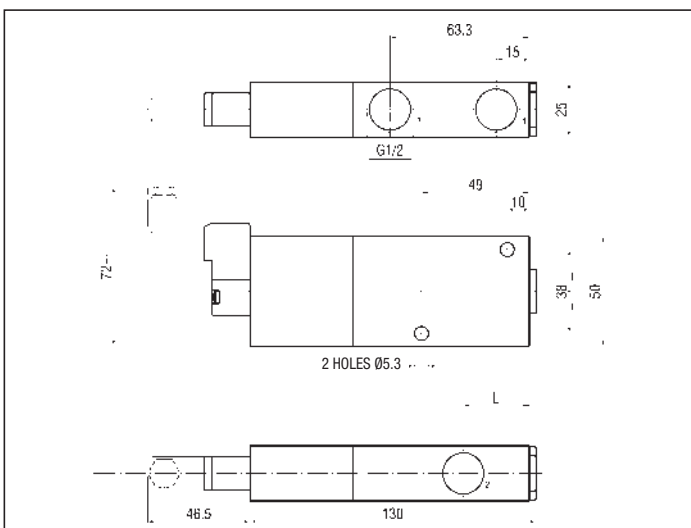

3 PORT BIG SOLENOID WITH ULCSV/R

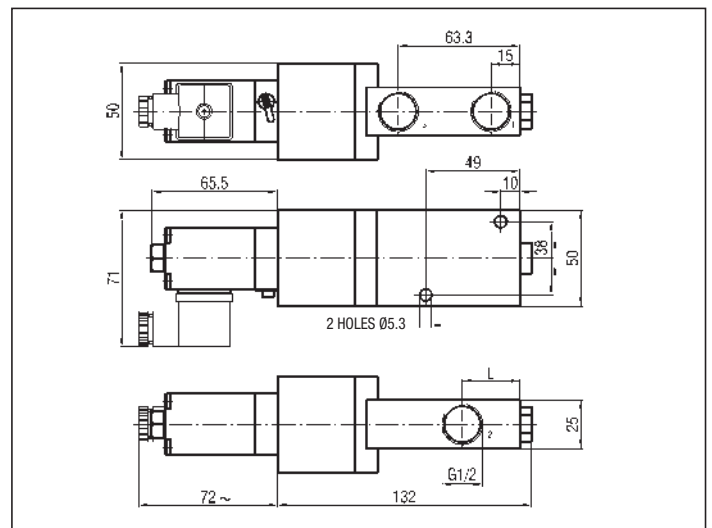

3 PORT BIG SOLENOID WITH C/USCSVG

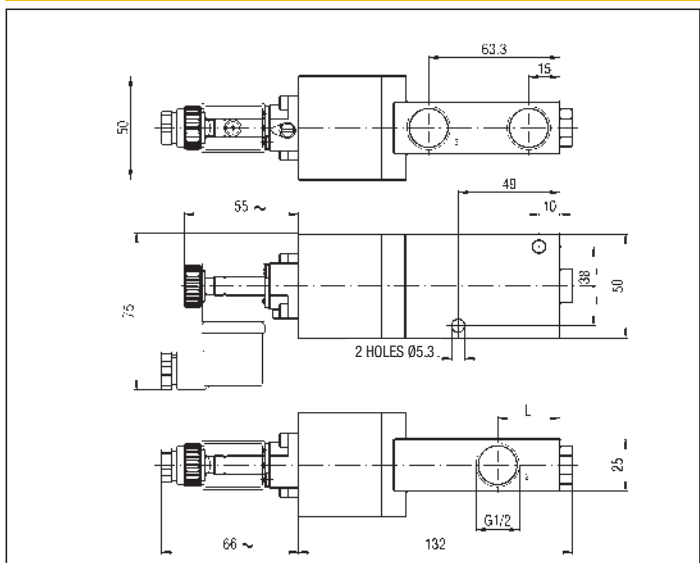

5 PORT WITH ULCSV/R

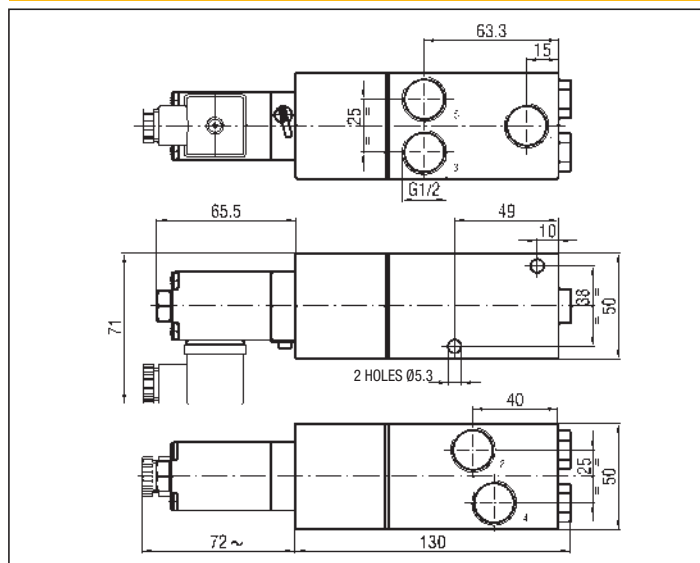

5 PORT WITH C/USCSVG

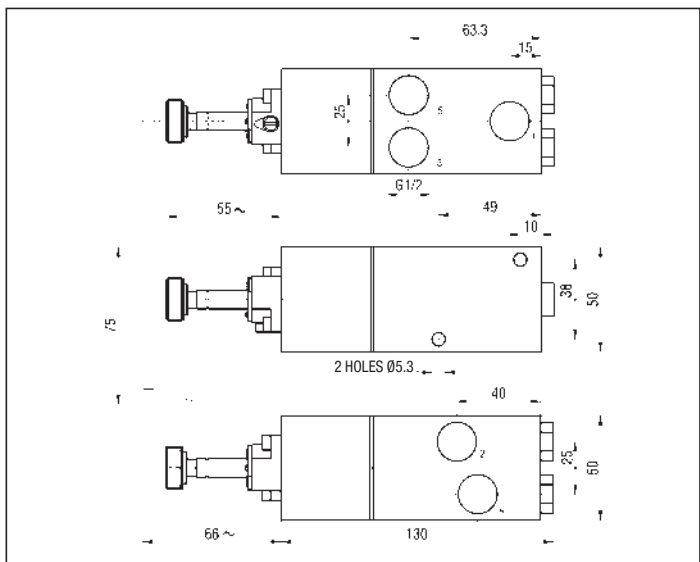

FUNCTION	L
3/2 N.O.	40
3/2 N.C.	30

FIXED LENGTH BASE FOR MANIFOLD MOUNTING OF VALVES G 1/2 - CK2

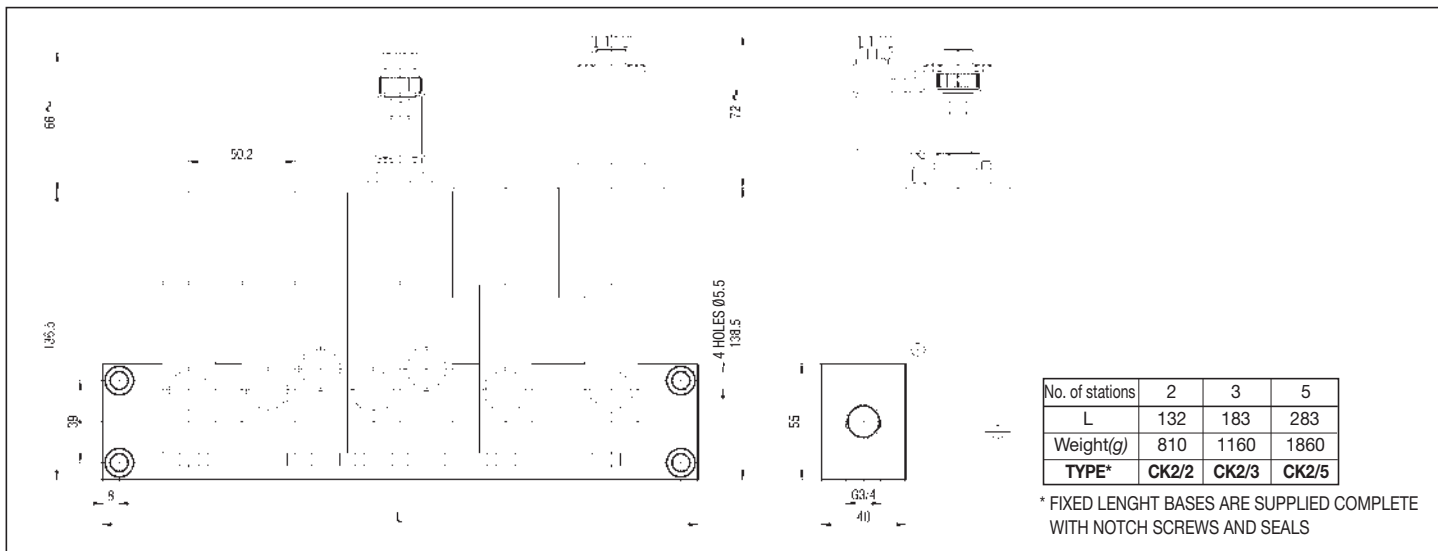

* FIXED LENGTH BASES ARE SUPPLIED COMPLETE WITH NOTCH SCREWS AND SEALS

PILOT ACTUATED VALVES* G 1 - 2, 3 AND 5 PORT

Symbol	Function	Controls		Response time at 6 bar (ms)		Flow rate at 6 bar $\Delta P = 1$ bar (NI/min)	Weight (g)	TYPE
		Pilot	Return	Energized	De-energized			
	3/2 N.O. monostable	Small pneumatic	Mechanical spring	40	65	11300	2550	UKA 1
	3/2 N.C. monostable	Small pneumatic	Mechanical spring	40	65	7800	2550	UKC 1**
	5/2 monostable	Pneumatic	Mechanical spring	40	70	8050	5160	UKCA 1

* FOR THE PILOT ACTUATED VALVES OBTAINABLE WITH "XVF4" SEE THE TABLE SOLENOID ACTUATED VALVES ON PAGE 2.73

** IF THE TYPE INCLUDES THE SUFFIX "/MR," THIS VALVE CAN BE USED TO SWITCH VACUUM

P.S.: ADD AT THE TYPE OF THE VALVES 3/2 THE LETTER "H" BETWEEN THE LETTERS "K" AND "A" (OR "C") TO ORDER 2/2 N.O. (OR 2/2 N.C.) VALVES. E.G.: UKHA 1; UKHC 1

UKA 1 - UKC 1

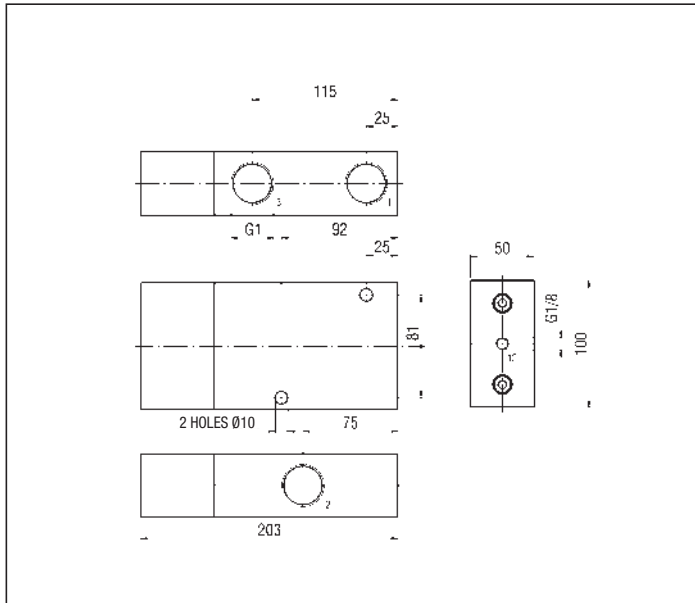

UKCA 1

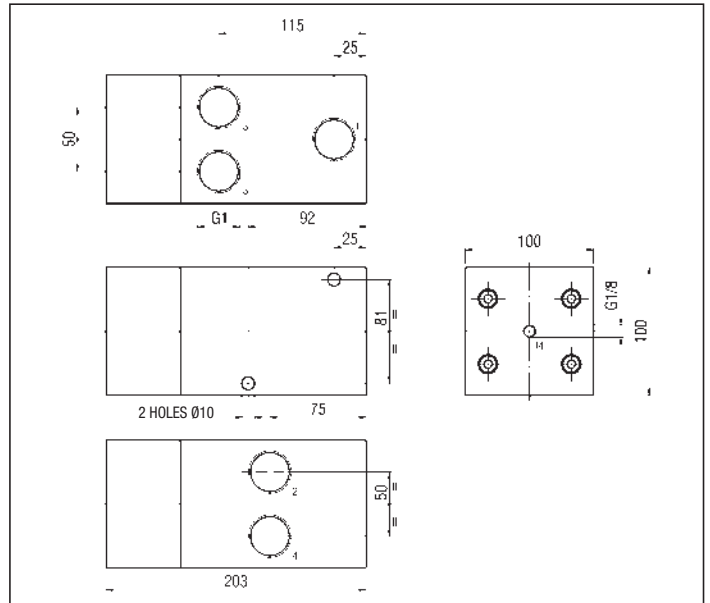

3 PORT WITH XVF4

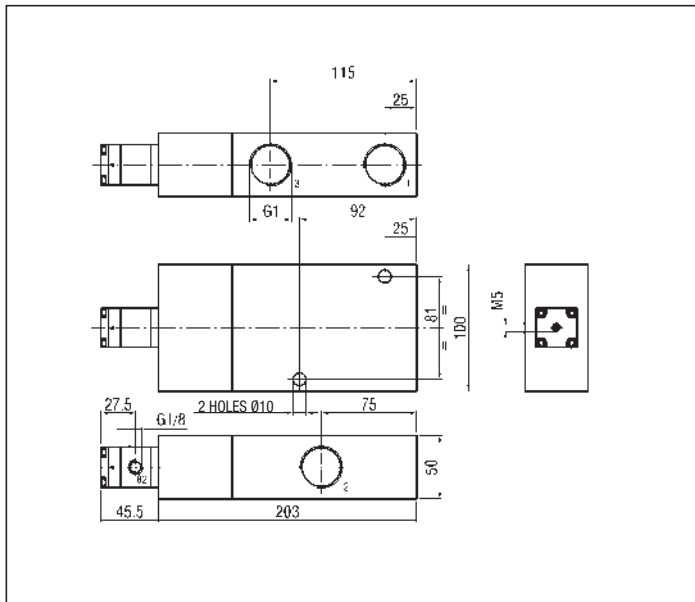

5 PORT WITH XVF4

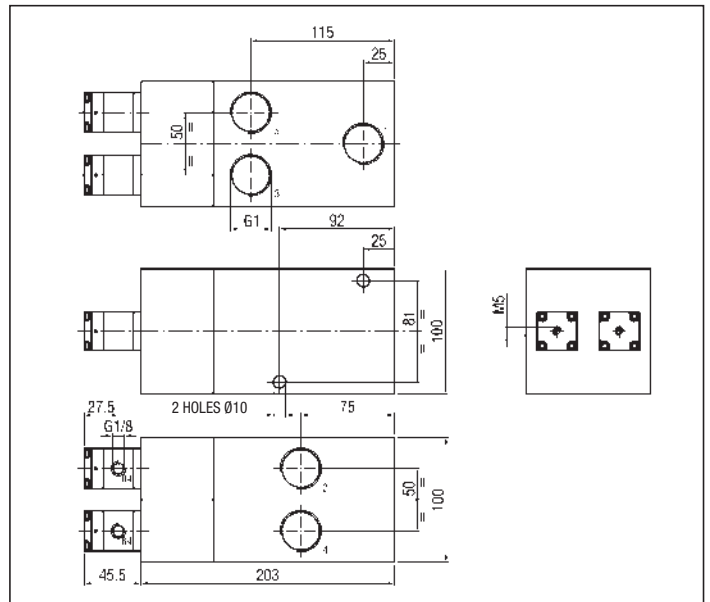

SOLENOID ACTUATED VALVES G 1 - 2, 3 AND 5 PORT

Symbol	Function	Controls		Response time at 6 bar (ms)		Flow rate at 6 bar $\Delta P = 1$ bar (Nl/min)	Weight (g)	TYPE*
		Pilot	Return	Energized	De-energized			
	3/2 N.O. monostable	Small solenoid	Mechanical spring	40	65	11300	2600	UKA 1/U
	3/2 N.C. monostable	Small solenoid	Mechanical spring	40	65	7800	2550	UKC 1/U
	5/2 monostable	Solenoid	Mechanical spring	40	70	8050	5100	UKCA 1/U

* THE TYPES OF THE SOLENOID VALVES DO NOT INCLUDE THE PILOTING SOLENOID VALVES (SEE ON PAGE 2.6 FOR "ULCSV/R" AND ON PAGE 2.13 FOR "C/USCSVG") WHEREAS USING AS PILOT THE VALVE "XVF4" THE RESULT IS A LOW PRESSURE PILOT ACTUATED VALVE (FOR "XVF4" - SEE ON PAGE 3.37)

P.S.: ADD AT THE TYPE OF THE VALVES 3/2 THE LETTER "H" BETWEEN THE LETTERS "K" AND "A" (OR "C") TO ORDER 2/2 N.O. (OR 2/2 N.C.) VALVES.

E.G.: UKHA 1/U; UKHC 1/U

3 PORT WITH ULCSV/R

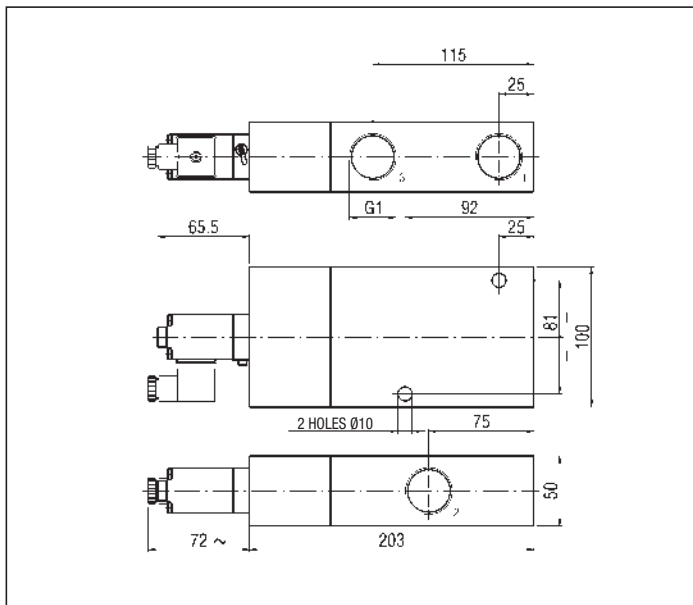

3 PORT WITH C/USCSVG

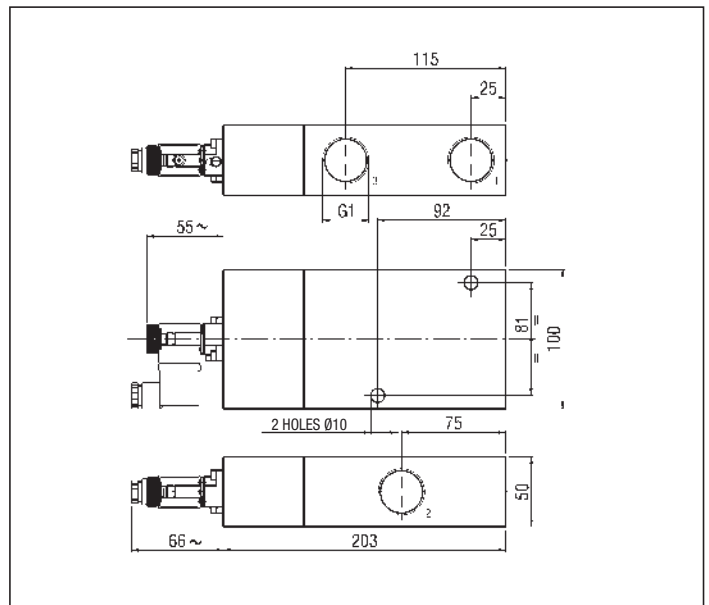

5 PORT WITH ULCSV/R

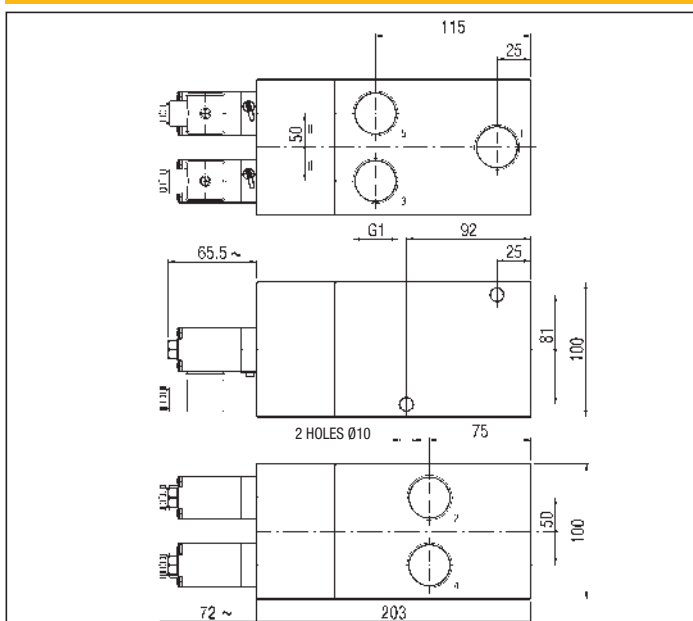

5 PORT WITH C/USCSVG

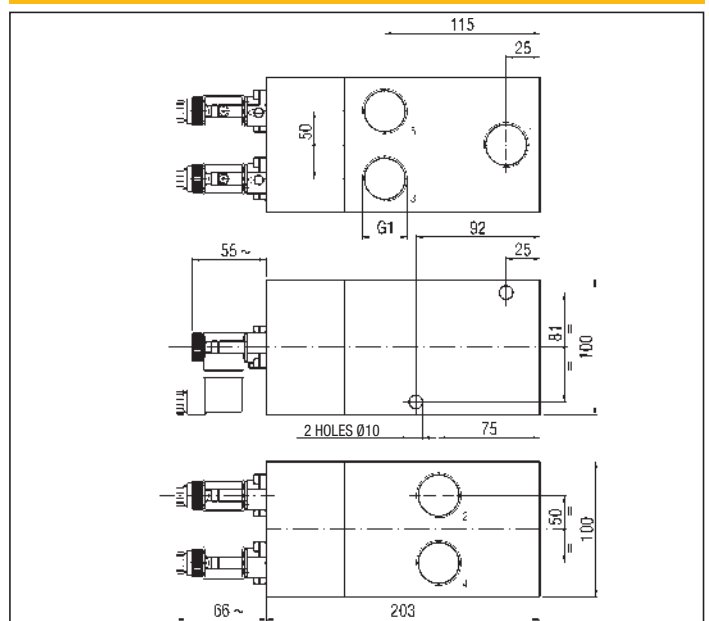

series UDS ISO

Valves to ISO 5599/1 standard
pilot and solenoid actuated
sizes 1 - 2 - 3

DESCRIPTION

Valves series "UDS ISO" are produced in the 5/2 and 5/3 pneumatic functions according to the interface to ISO 5599/1 standard and they are mounted onto single or manifold bases, bottom or side ported. The ex CNOMO solenoid valve, with manual override (screwdriver type C/UECSVB or button type C/UECSPB), in the solenoid actuated version is mounted with coil type USBG side 30 mm (that allows a greater yield) or type USB side 22 mm.

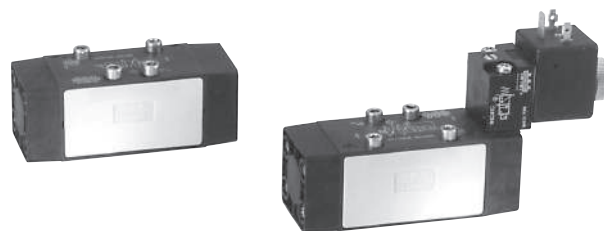

2

TECHNICAL DATA

Operating pressure	Monostable: 2,5 ÷ 10 bar Bistable: 1,5 ÷ 10 bar
Working temperature	0 ÷ +50 °C (-20 °C with dry air)
Fluid	Filtered, unlubricated or continuous lubricated compressed air
Port size	Interface to ISO 5599/1
Pneumatic piloting port size	Interface to ISO 5599/1
Piloting solenoid valves	C/UECSVB - C/UECSPB - see chapter Direct acting solenoid valves series ex CNOMO on page 2.12
Coils	USBG - see chapter Coils on page 2.14 USB - see chapter Coils on page 2.14
Electric connectors	ULR1B - see chapter Connectors on page 2.15 USR102/N9 - see chapter Connectors on page 2.15

MATERIALS

Bottoms	Size 1 - 2: Techno-polymer Size 3: Aluminium alloy
Body	Size 1 - 2: Techno-polymer Size 3: Aluminium alloy
Distance rings	Acetal resin
Springs	Galvanized steel
Seals	NBR rubber + steel insert
Spool	Aluminium alloy
Piston	Aluminium alloy

SPARE PARTS

SEALS KIT	
Size 1	UDS/SG/105
Size 2	UDS/SG/212
Size 3	UDSI/SG/3

FLOW CHART SIZE 1

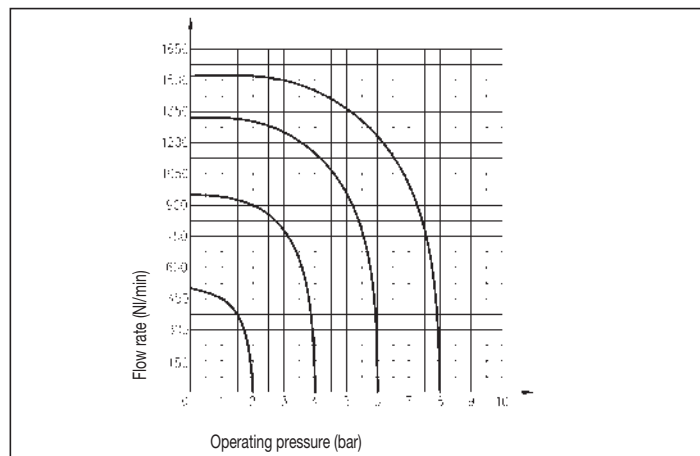

PILOTING CHART SIZE 1

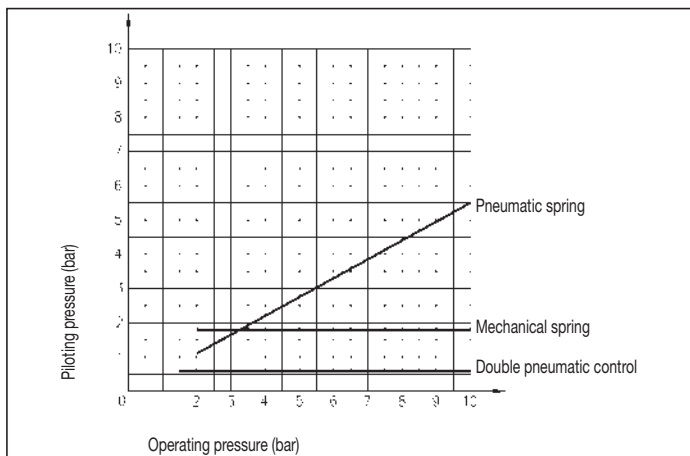

FLOW CHART SIZE 2

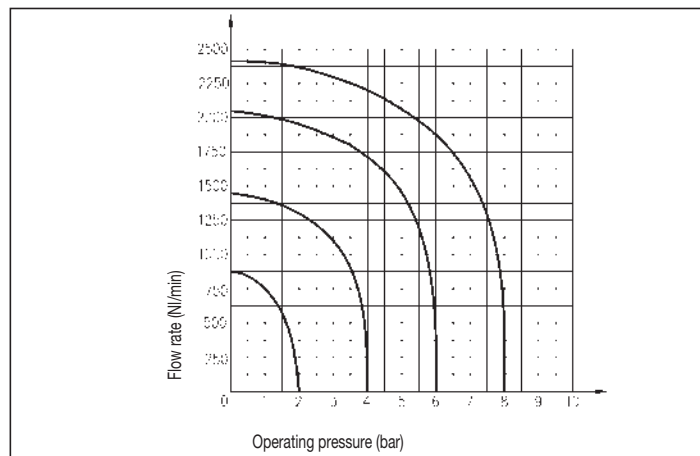

PILOTING CHART SIZE 2

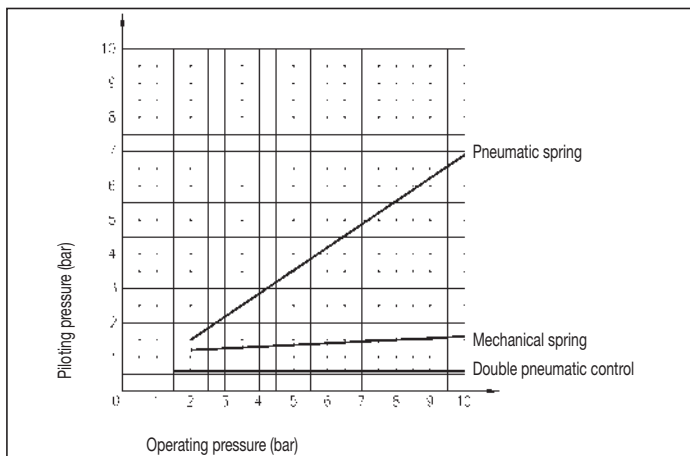

FLOW CHART SIZE 3

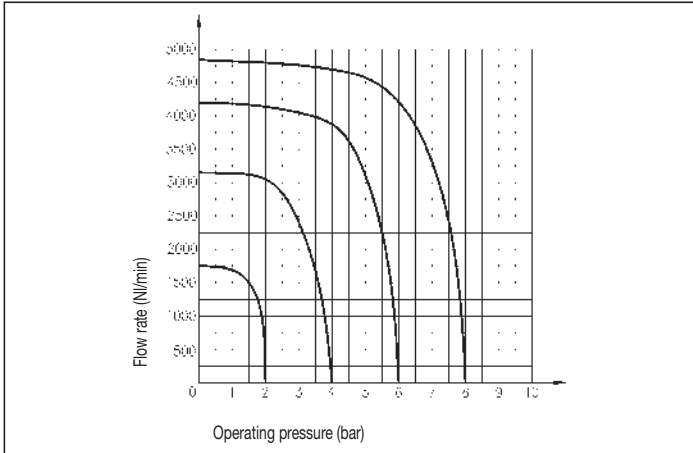

PILOTING CHART SIZE 3

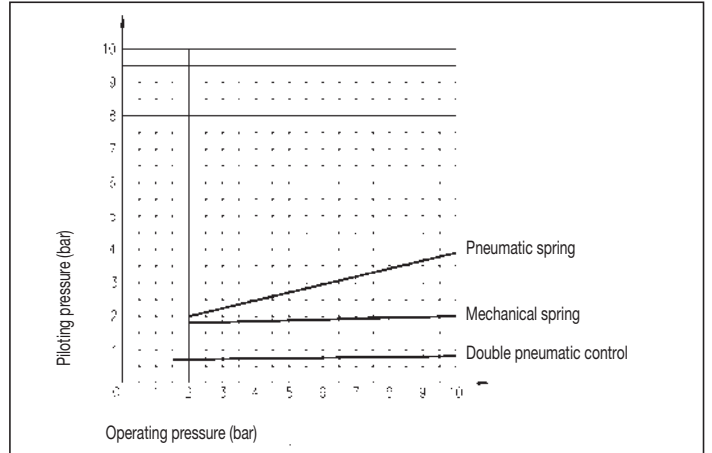

PILOT ACTUATED VALVES SIZE 1

Symbol	Function	Controls		Response times at 6 bar (ms)		Flow rate at 6 bar $\Delta P = 1$ bar (NI/min)	Weight (g)	TYPE
		Actuation	Return	Energized	De-energized			
	5/2 monostable	Pneumatic	Mechanical spring	20	30	960	230	UDS 105 KR/ZR
		Pneumatic	Pneumatic spring	20	14	960	230	UDS 105 KR/TQ
	5/2 bistable	Pneumatic	Pneumatic	15	15	960	230	UDS 105 KR/KR
	5/2 bistable with override on body valve	Pneumatic	Pneumatic	15	15	960	250	UDS 105 KRP/KRP
	5/2 bistable	Pneumatic	Pneumatic differential	15	20	960	230	UDS 105 KR/TR
	5/3 closed centre	Pneumatic	Mechanical spring	20	25	580	275	UDS 105 SR/SR
	5/3 open centre	Pneumatic	Mechanical spring	20	25	800	275	UDS 105 AR/AR
	5/3 pressure centre	Pneumatic	Mechanical spring	20	25	1100	275	UDS 105 PR/PR

5 PORT SIZE 1

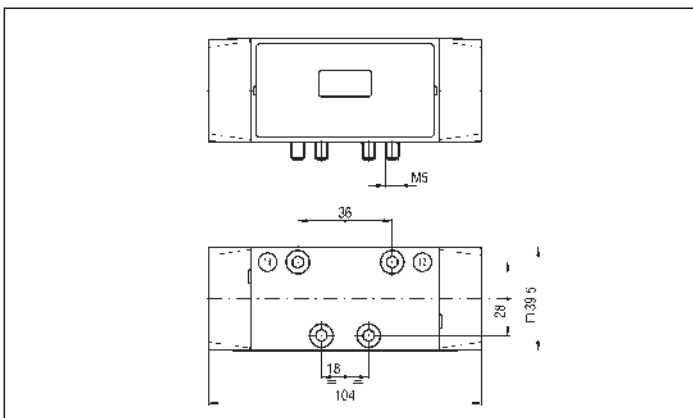

5 PORT SIZE 1 WITH MANUAL OVERRIDE ON BODY VALVE

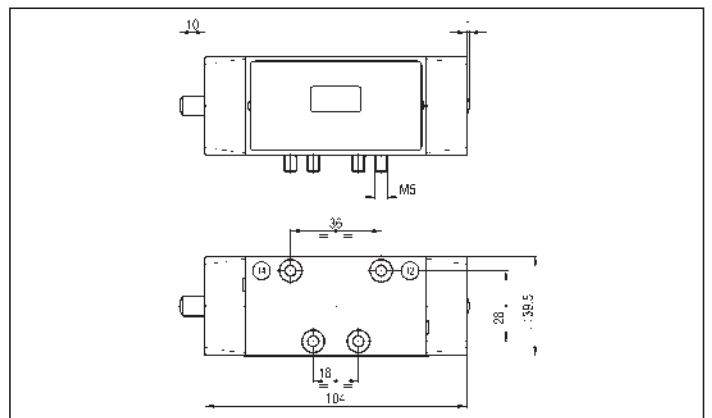

series UDS ISO

2

SOLENOID ACTUATED VALVES SIZE 1

Symbol	Function	Controls		Response time at 6 bar (ms)		Flow rate at 6 bar $\Delta P = 1$ bar (NI/min)	Weight (g)	TYPE*
		Pilot	Return	Energized	De-energized			
	5/2 monostable	Solenoid	Mechanical spring	20	30	960	305	UDS 105 KUEC/ZR
		Solenoid	Pneumatic spring	20	30	960	305	UDS 105 KUEC/TQ
		Solenoid pilot assisted	Mechanical spring	20	30	960	305	UDS 105 KUER/ZR
	5/2 bistable	Solenoid	Small pneumatic	20	25	960	310	UDS 105 KUEC/TR
		Solenoid pilot assisted	Small pneumatic	20	25	960	310	UDS 105 KUER/TR
		Solenoid	Solenoid	15	15	960	375	UDS 105 KUEC/KUEC
		Solenoid pilot assisted	Solenoid pilot assisted	15	15	960	375	UDS 105 KUER/KUER
	5/3 closed centre	Solenoid	Mechanical spring	20	25	580	425	UDS 105 SUEC/SUEC
		Solenoid pilot assisted	Mechanical spring	20	25	580	425	UDS 105 SUER/SUER
	5/3 open centre	Solenoid	Mechanical spring	20	25	800	425	UDS 105 AUEC/AUEC
		Solenoid pilot assisted	Mechanical spring	20	25	800	425	UDS 105 AUER/AUER
	5/3 pressure centre	Solenoid	Mechanical spring	20	25	1100	425	UDS 105 PUEC/PUEC
		Solenoid pilot assisted	Mechanical spring	20	25	1100	425	UDS 105 PUER/PUER

* - SUBSTITUTE THE LETTER "E" WITH THE LETTER "P" IN EACH SOLENOID CONTROL TYPE TO ORDER THE SOLENOID ACTUATED VALVES TO ISO STANDARD WITH MANUAL OVERRIDE (MONOSTABLE BUTTON) ON THE PILOTING SOLENOID VALVES, E.G.: UDS 105 KUEC/TR BECOMES UDS 105 KUPC/TR - UDS 105 KUEC/KUEC BECOMES UDS 105 KUPC/KUPC
 - CANCEL THE LETTER "E" FROM THE TYPE TO ORDER THE SOLENOID ACTUATED VALVES TO ISO STANDARD WITHOUT THE PILOTING SOLENOID VALVES, E.G.: UDS 105 KUEC/ZR BECOMES UDS 105 KUC/ZR
 - THE TYPES OF THE SOLENOID VALVES DO NOT INCLUDE COILS

5 PORT SIZE 1 MONOSTABLE

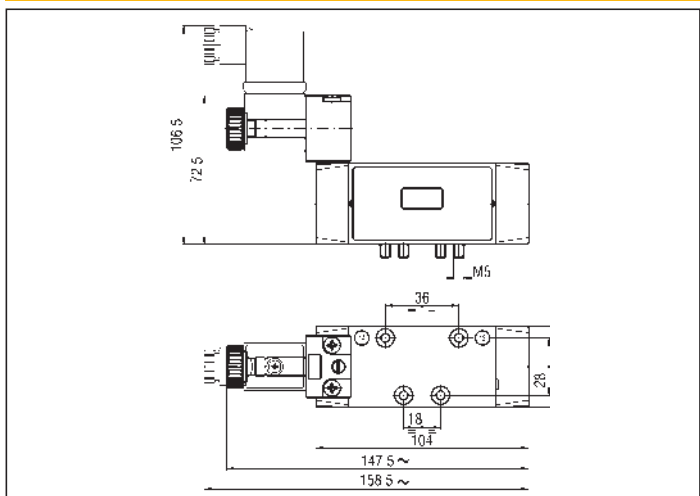

5 PORT SIZE 1 BISTABLE AND 3 POSITIONS

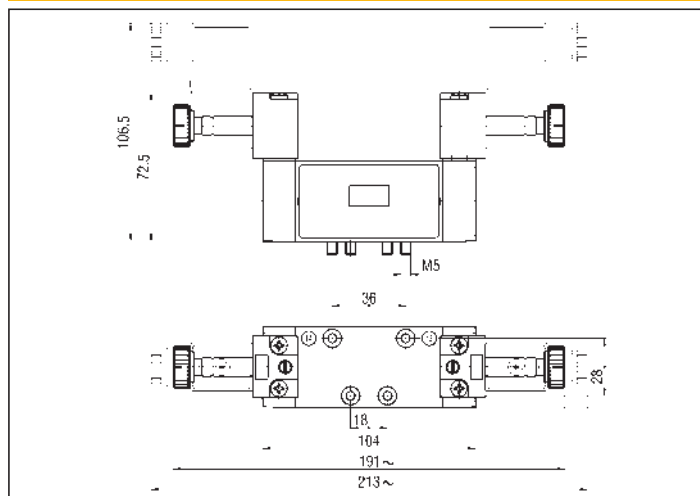

PILOT ACTUATED VALVES SIZE 2

Symbol	Function	Controls		Response time at 6 bar (ms)		Flow rate at 6 bar $\Delta P = 1 \text{ bar (NI/min)}$	Weight (g)	TYPE
		Pilot	Return	Energized	De-energized			
	5/2 monostable	Pneumatic	Mechanical spring	47	50	1500	515	UDS 212 KR/ZR
		Pneumatic	Pneumatic spring	47	50	1500	510	UDS 212 KR/TQ
	5/2 bistable	Pneumatic	Pneumatic	23	23	1500	515	UDS 212 KR/KR
		Pneumatic	Pneumatic differential	20	40	1500	515	UDS 212 KR/TR
	5/3 closed centre	Pneumatic	Mechanical spring	30	35	1000	580	UDS 212 SR/SR
	5/3 open centre	Pneumatic	Mechanical spring	30	35	1200	580	UDS 212 AR/AR
	5/3 pressure centre	Pneumatic	Mechanical spring	30	35	1300	580	UDS 212 PR/PR

5 PORT SIZE 2

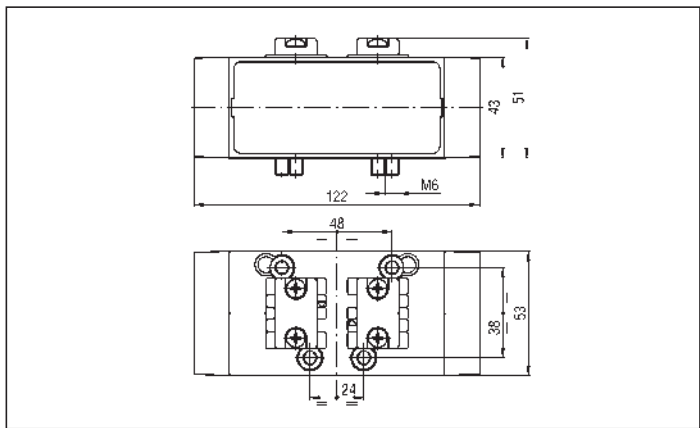

series UDS ISO

2

SOLENOID ACTUATED VALVES SIZE 2

Symbol	Function	Controls		Response time at 6 bar (ms)		Flow rate at 6 bar $\Delta P = 1$ bar (NI/min)	Weight (g)	TYPE*
		Pilot	Return	Energized	De-energized			
	5/2 monostable	Solenoid	Mechanical spring	40	45	1500	580	UDS 212 KUEC/ZR
		Solenoid	Pneumatic spring	47	50	1500	580	UDS 212 KUEC/TQ
		Solenoid pilot assisted	Mechanical spring	40	45	1500	580	UDS 212 KUER/ZR
	5/2 bistable	Solenoid	Small pneumatic	40	45	1500	580	UDS 212 KUEC/TR
		Solenoid pilot assisted	Small pneumatic	40	45	1500	580	UDS 212 KUER/TR
		Solenoid	Solenoid	20	20	1500	635	UDS 212 KUEC/KUEC
		Solenoid pilot assisted	Solenoid pilot assisted	20	20	1500	635	UDS 212 KUER/KUER
	5/3 closed centre	Solenoid	Mechanical spring	30	35	1000	720	UDS 212 SUEC/SUEC
		Solenoid pilot assisted	Mechanical spring	30	35	1000	720	UDS 212 SUER/SUER
	5/3 open centre	Solenoid	Mechanical spring	30	35	1200	720	UDS 212 AUEC/AUEC
		Solenoid pilot assisted	Mechanical spring	30	35	1200	720	UDS 212 AUER/AUER
	5/3 pressure centre	Solenoid	Mechanical spring	30	35	1300	720	UDS 212 PUEC/PUEC
		Solenoid pilot assisted	Mechanical spring	30	35	1300	720	UDS 212 PUER/PUER

* - SUBSTITUTE THE LETTER "E" WITH THE LETTER "P" IN EACH SOLENOID CONTROL TYPE TO ORDER THE SOLENOID ACTUATED VALVES TO ISO STANDARD WITH MANUAL OVERRIDE (MONOSTABLE BUTTON) ON THE PILOTING SOLENOID VALVES, E.G.: UDS 212 KUEC/TR BECOMES UDS 212 KUPC/TR - UDS 212 KUEC/KUEC BECOMES UDS 212 KUPC/KUPC
 - CANCEL THE LETTER "E" FROM THE TYPE TO ORDER THE SOLENOID ACTUATED VALVES TO ISO STANDARD WITHOUT THE PILOTING SOLENOID VALVES, E.G.: UDS 212 KUEC/ZR BECOMES UDS 212 KUC/ZR
 - THE TYPES OF THE SOLENOID VALVES DO NOT INCLUDE COILS

5 PORT SIZE 2 MONOSTABLE

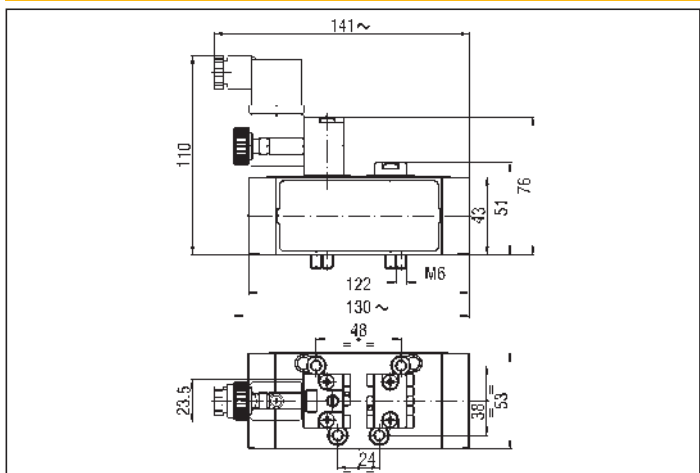

5 PORT SIZE 2 BISTABLE AND 3 POSITIONS

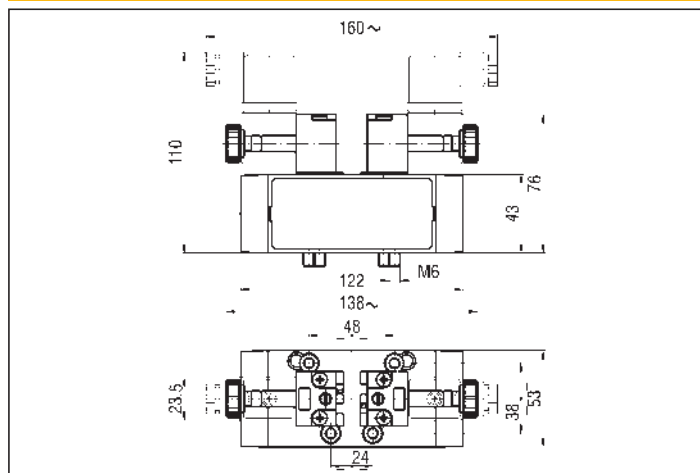

PILOT ACTUATED VALVES SIZE 3

Symbol	Function	Controls		Response time at 6 bar (ms)		Flow rate at 6 bar $\Delta P = 1 \text{ bar (Nl/min)}$	Weight (g)	TYPE
		Pilot	Return	Energized	De-energized			
	5/2 monostable	Pneumatic	Mechanical spring	38	42	3000	1995	UDSI 3 KR/ZR
		Pneumatic	Pneumatic spring	38	42			
	5/2 bistable	Pneumatic	Pneumatic	28	28	3000	1965	UDSI 3 KR/KR
		Pneumatic	Pneumatic differential	28	35			
	5/3 closed centre	Pneumatic	Mechanical spring	27	32	2900	2020	UDSI 3 SR/SR
	5/3 open centre	Pneumatic	Mechanical spring	27	32	3000	2020	UDSI 3 AR/AR

5 PORT SIZE 3

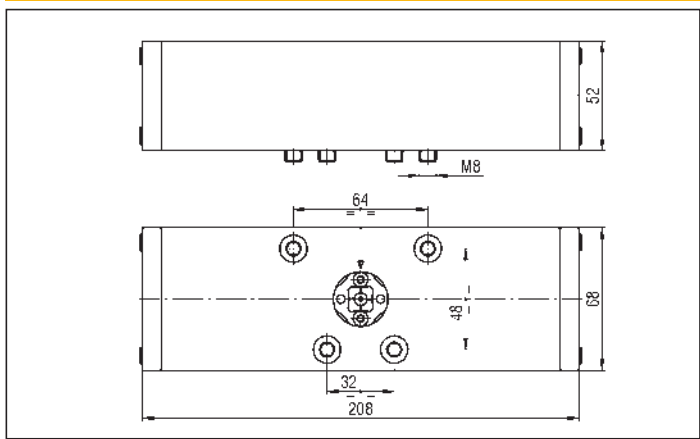

2

SOLENOID ACTUATED VALVES SIZE 3

Symbol	Function	Controls		Response time at 6 bar (ms)		Flow rate at 6 bar $\Delta P = 1$ bar (NI/min)	Weight (g)	TYPE*
		Pilot	Return	Energized	De-energized			
	5/2 monostable	Solenoid	Mechanical spring	40	42	3100	2120	UDSI 3 KUEC/ZR
		Solenoid	Pneumatic spring	40	42	3100	2120	UDSI 3 KUEC/TQ
		Solenoid pilot assisted	Mechanical spring	40	42	3100	2120	UDSI 3 KUER/ZR
	5/2 bistable	Solenoid	Small pneumatic	40	45	3100	2120	UDSI 3 KUEC/TR
		Solenoid pilot assisted	Small pneumatic	40	45	3100	2120	UDSI 3 KUER/TR
		Solenoid	Solenoid	28	28	3100	2180	UDSI 3 KUEC/KUEC
		Solenoid pilot assisted	Solenoid pilot assisted	28	28	3100	2180	UDSI 3 KUER/KUER
	5/3 closed centre	Solenoid	Mechanical spring	27	32	2900	2180	UDSI 3 SUEC/SUEC
		Solenoid pilot assisted	Mechanical spring	27	32	2900	2180	UDSI 3 SUER/SUER
	5/3 open centre	Solenoid	Mechanical spring	27	32	3000	2180	UDSI 3 AU EC/AUEC
		Solenoid pilot assisted	Mechanical spring	27	32	3000	2180	UDSI 3 AUER/AUER

* - SUBSTITUTE THE LETTER "E" WITH THE LETTER "P" IN EACH SOLENOID CONTROL TYPE TO ORDER THE SOLENOID ACTUATED VALVES TO ISO STANDARD WITH MANUAL OVERRIDE (MONOSTABLE BUTTON) ON THE PILOTING SOLENOID VALVES, E.G.: UDSI 3 KUEC/TR BECOMES UDSI 3 KUPC/TR - UDS1 3 KUEC/KUEC BECOMES UDSI 3 KUPC/KUPC
 - CANCEL THE LETTER "E" FROM THE TYPE TO ORDER THE SOLENOID ACTUATED VALVES TO ISO STANDARD WITHOUT THE PILOTING SOLENOID VALVES, E.G.: UDSI 3 KUEC/ZR BECOMES UDSI 3 KUC/ZR - THE TYPES OF THE SOLENOID VALVES DO NOT INCLUDE COILS

5 PORT SIZE 3 MONOSTABLE

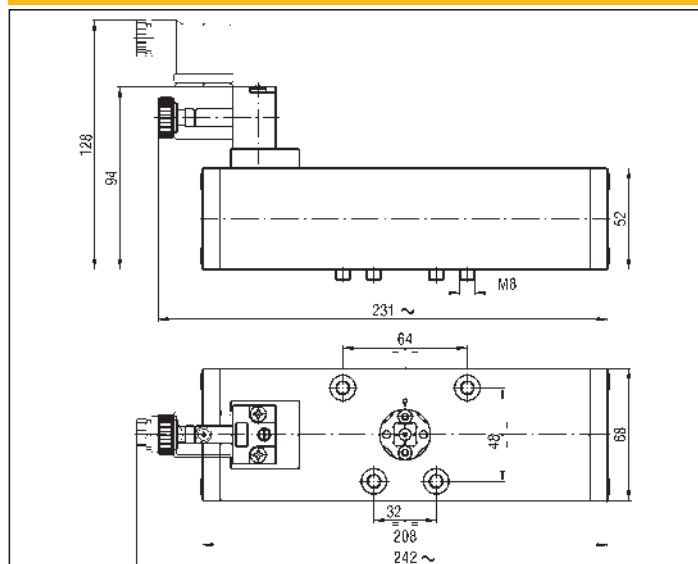

5 PORT SIZE 3 BISTABLE E 3 POSITIONS

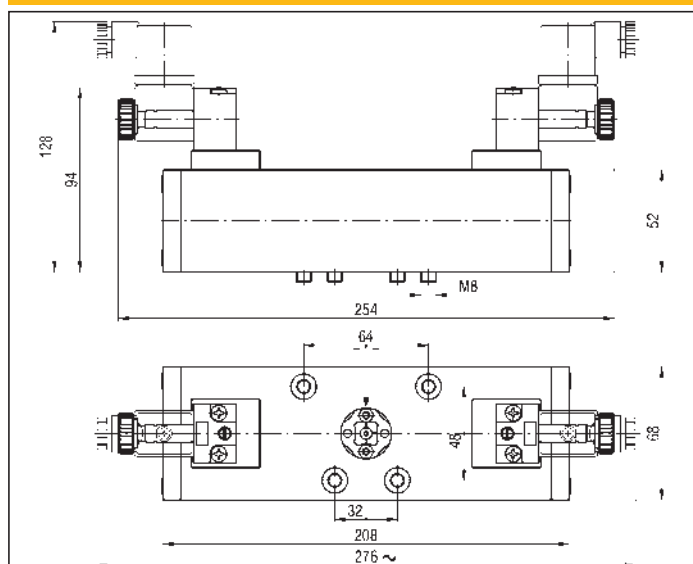

SINGLE BASE SIDE PORTED - UDP/ISO SIZE /S

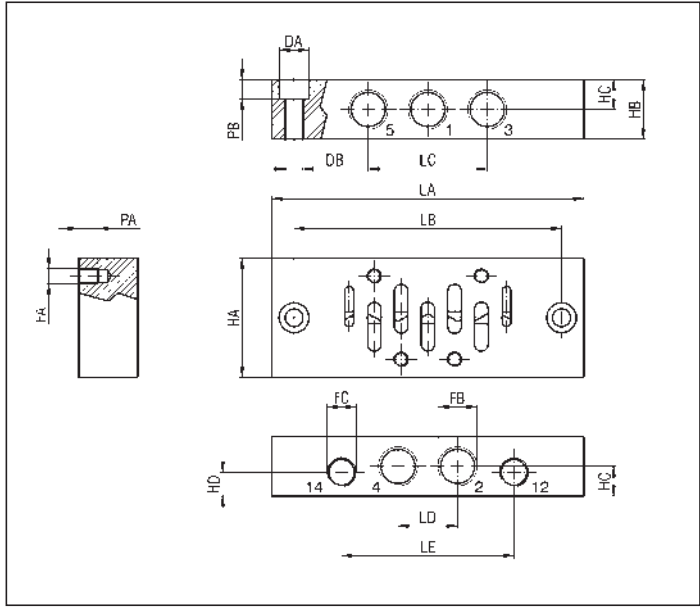

TYPE	UDP/ISO1/S8	UDP/ISO1/S4	UDP/ISO2/S4	UDP/ISO2/S3	UDP/ISO3/S2
Weight (g)	205	240	485	455	1090
SIZE	1		2		3
DA	10	10	12	12	15
DB	6	6	7	7	9
FA	M5	M5	M6	M6	M8
FB	G 1/8	G 1/4	G 1/4	G 3/8	G 1/2
FC	G 1/8	G 1/8	G 1/8	G 1/8	G 1/8
HA	40	40	55	55	70
HB	20	25	28	28	32
HC	8	14,5	13	15	16
HD	8	8	8	8	8
LA	105	105	130	130	208
LB	90	90	110	110	180
LC	36	40	48	52	64
LD	18	20	24	26	32
LE	58	58	68	70	90
PA	6,5	6,5	10	10	10
PB	6,5	6,5	8	8	11

SINGLE BASE BOTTOM PORTED - UDP/ISO SIZE /B

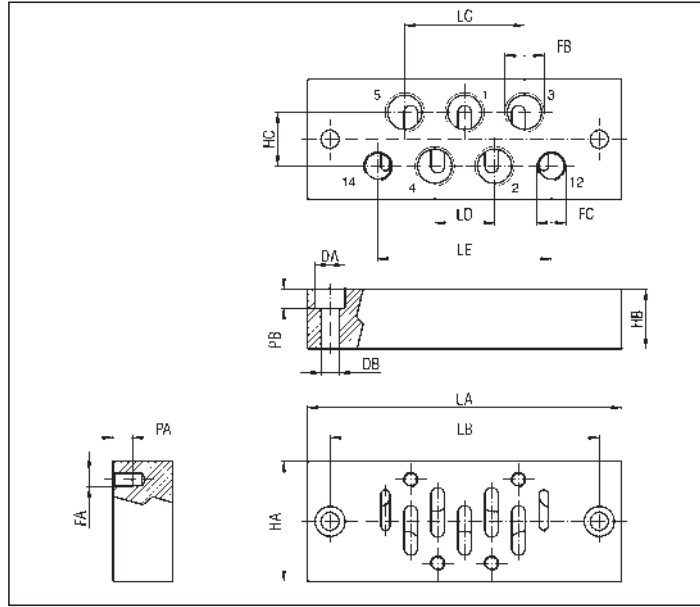

TYPE	UDP/ISO1/B8	UDP/ISO1/B4	UDP/ISO2/B4	UDP/ISO2/B3	UDP/ISO3/B2
Weight (g)	200	190	495	470	1160
SIZE	1		2		3
DA	10	10	12	12	15
DB	6	6	7	7	9
FA	M5	M5	M6	M6	M8
FB	G 1/8	G 1/4	G 1/4	G 3/8	G 1/2
FC	G 1/8	G 1/8	G 1/8	G 1/8	G 1/8
HA	40	40	55	55	70
HB	20	20	28	28	32
HC	16	18	22	23	27
LA	105	105	130	130	208
LB	90	90	110	110	180
LC	36	40	48	52	64
LD	18	20	24	26	32
LE	58	58	68	70	90
PA	8	8	10	10	10
PB	6,5	6,5	8	8	11

series UDS ISO

Manifold bases to ISO 5599/1
standard sizes 1-2-3
obtained from drawn light alloy

2

MANIFOLD BASE SIDE PORTED - UDP/ISO SIZE /MS/Q

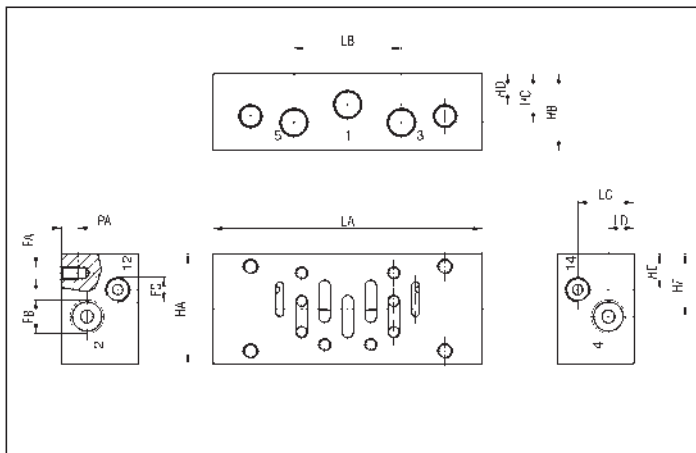

TYPE	UDP/ISO1/8MS/Q	UDP/ISO1/4MS/Q	UDP/ISO2/3MS/Q
Weight (g)	320	310	660
SIZE	ISO 1		ISO 2
FA	M5	M5	M6
FB	G 1/8	G 1/4	G 3/8
FC	G 1/8	G 1/8	G 1/8
HA	43	43	55
HB	30	30	40
HC	19	19	24
HD	12	12	17
HE	14	14	17,5
HF	24,5	24,5	30
LA	105	105	130
LB	42	42	54
LC	22	22	30
LD	10	10	12,5
PA	6,5	6,5	8

MANIFOLD BASE BOTTOM PORTED - UDP/ISO SIZE M/Q

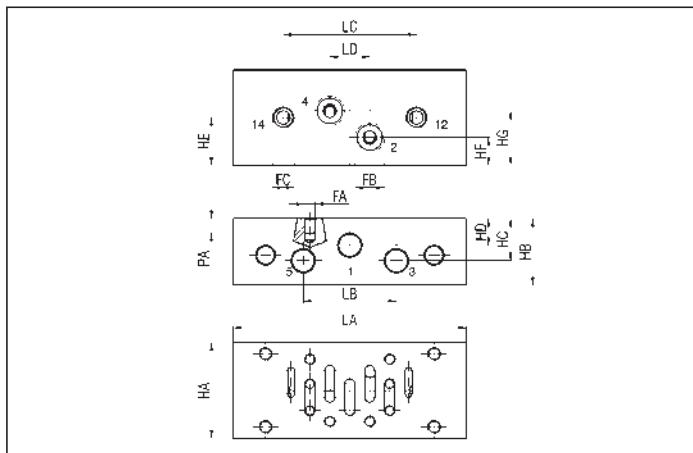

TYPE	UDP/ISO1/8M/Q	UDP/ISO1/4M/Q	UDP/ISO2/3M/Q	UDP/ISO3/2M/Q
Weight (g)	320	315	665	1640
SIZE	ISO 1		ISO 2	ISO 3
FA	M5	M5	M6	M8
FB	G 1/8	G 1/4	G 3/8	G 1/2
FC	G 1/8	G 1/8	G 1/8	G 1/8
HA	43	43	55	70
HB	30	30	40	50
HC	19	19	24	27
HD	12	12	17	27
HE	21,5	21,5	27,5	35
HF	12,5	12,5	16,5	23,5
HG	24,5	24,5	32,5	42,5
LA	105	105	130	208
LB	42	42	54	88
LC	60	60	74	125
LD	18	18	24	42
PA	6,5	6,5	8	10

INPUT PLATES (pair) - UDP/ISO SIZE /...M/L

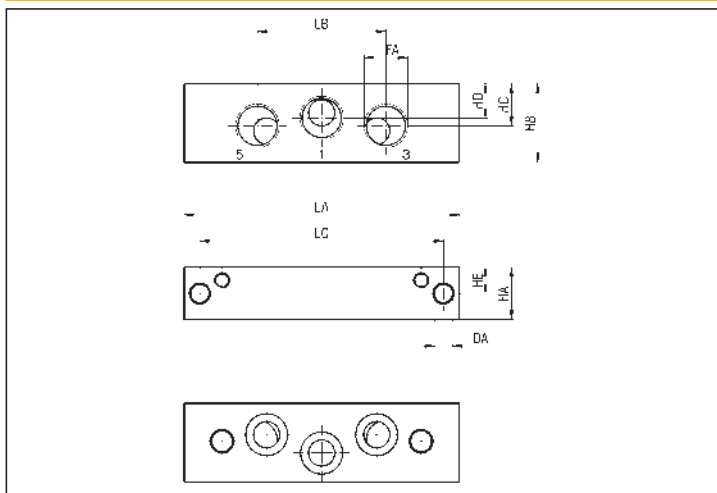

TYPE	UDP/ISO1/3M/L	UDP/ISO2/2M/L	UDP/ISO3/1M/L
Weight (g)	280	460	2355
SIZE	ISO 1	ISO 2	ISO 3
DA	7	7	9
FA	G 3/8	G 1/2	G 1
HA	20	20	50
HB	30	40	50
HC	16	22	25
HD	13	15	25
HE	10	10	25
LA	105	130	208
LB	49	59	94
LC	93	118	180

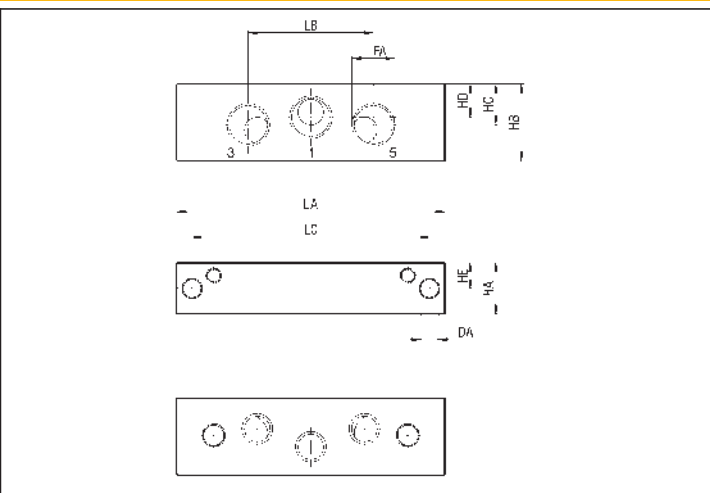

BLANKING PLATE ISO 1 - UDP/ISO1/PC

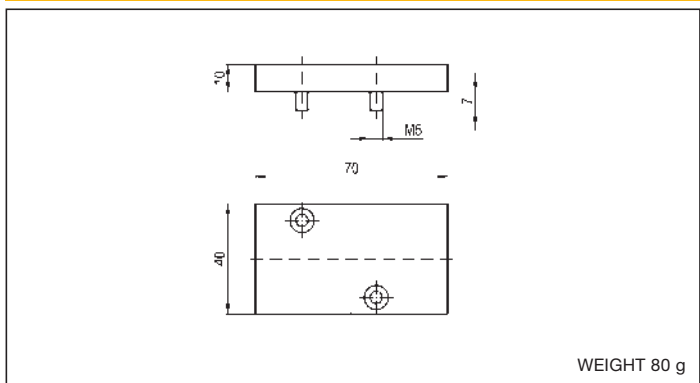

WEIGHT 80 g

BLANKING PLATE ISO 2 - UDP/ISO2/PC

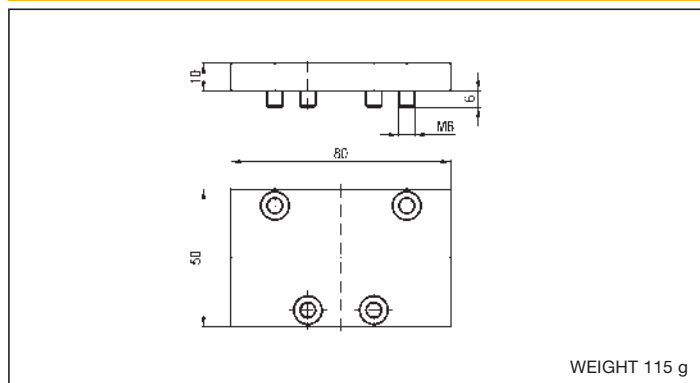

WEIGHT 115 g

SIZE ADAPTER ISO 1-2 AND ISO 2-3 - UDP/ISO SIZE

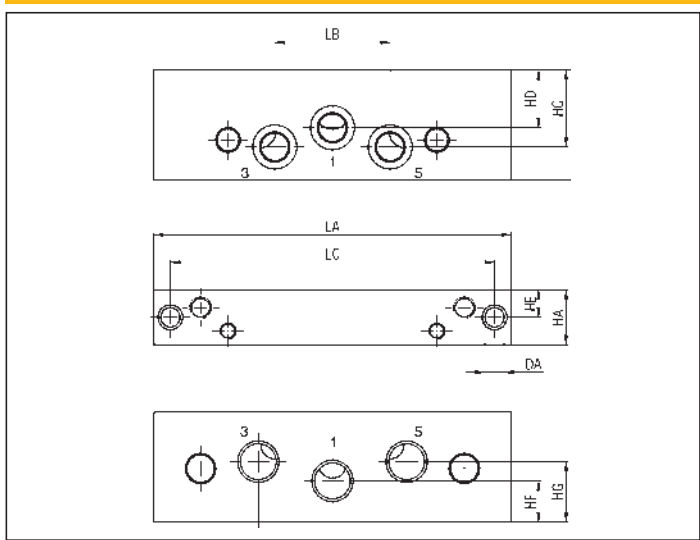

TYPE	UDP/ISO1-2	UDP/ISO2-3
Weight (g)	245	1305
SIZE	1-2	2-3
DA	7	9
HA	20	50
HB	40	50
HC	28	32
HD	21	35
HE	10	25
HF	15	25
HG	22	25
LA	130	208
LB	42	54
LC	118	180
LD	54	88

KIT ASSEMBLY BASES

Kit assembly bases ISO 1	KIT/UDP/ISO 1
Kit assembly bases ISO 2	KIT/UDP/ISO 2
Kit assembly bases ISO 3	KIT/UDP/ISO 3

DIAPHRAGM - UDP/ISO SIZE /T

TYPE	UDP/ISO1/T	UDP/ISO2/T	UDP/ISO3/T
SIZE	1	2	3

EXAMPLE OF ASSEMBLY

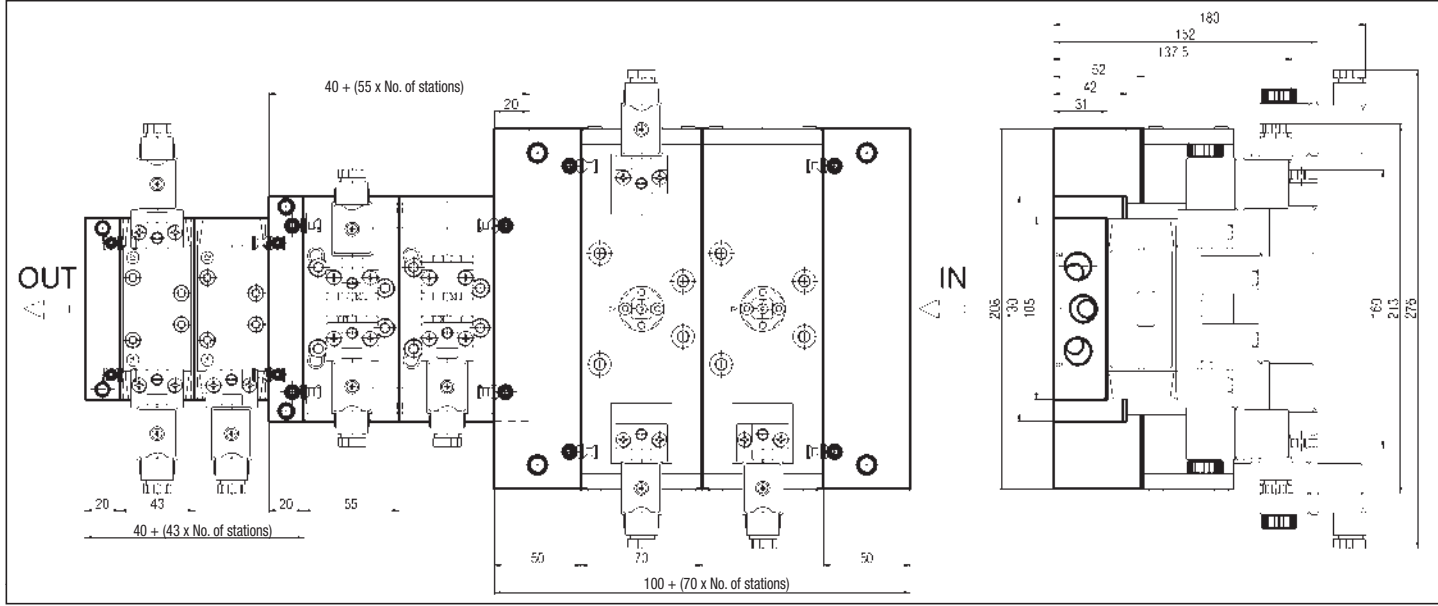

series UDS ISO

2

INPUT PLATE - UDP/ISO1PE

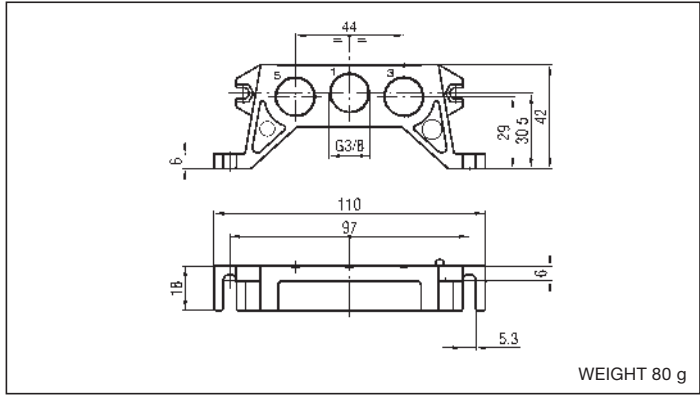

WEIGHT 80 g

INPUT PLATE IS SUPPLIED COMPLETE WITH SCREWS AND SEALS

BLIND TERMINAL PLATE - UDP/ISO1PT

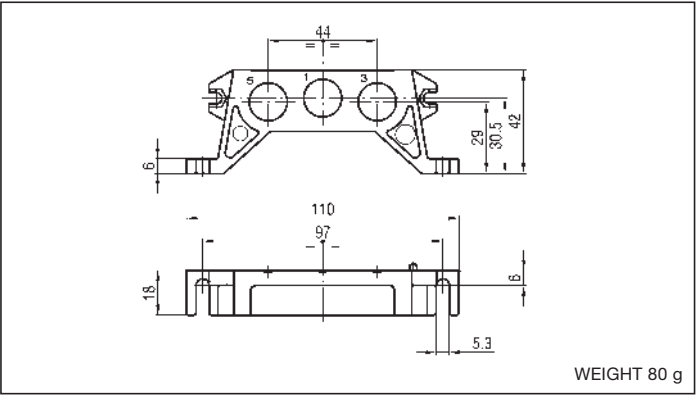

WEIGHT 80 g

UNIVERSAL PLATE

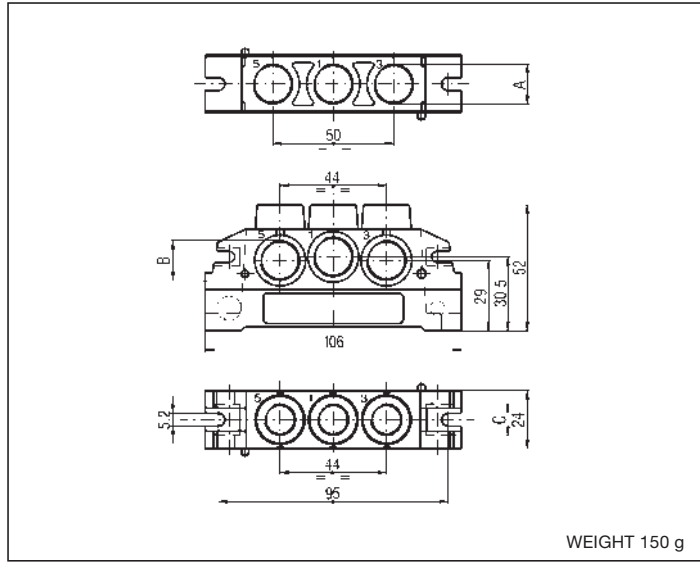

WEIGHT 150 g

DESCRIPTION	A	B	C	TYPE
Intermediate plate, bottom ported	G 3/8	-	-	UDP/ISO1PUI
Intermediate plate, side ported	-	G 3/8	-	UDP/ISO1PUL
Intermediate plate, top ported	-	-	G 1/4	UDP/ISO1PUS
Intermediate plate with blind holes	G 3/8	G 3/8	G 1/4	UDP/ISO1PU

PLATES ARE SUPPLIED COMPLETE WITH SCREWS AND SEALS

MANIFOLD BASE, SIDE AND BOTTOM PORTED - UDP/ISO1BM

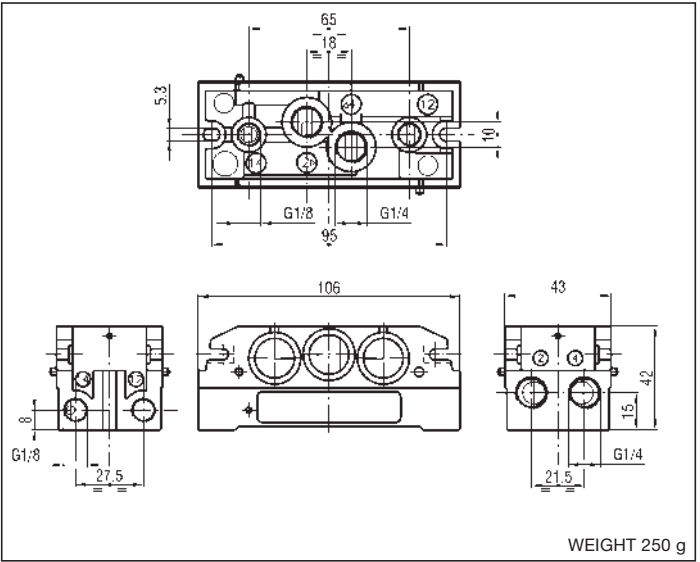

WEIGHT 250 g

MANIFOLD BASE IS SUPPLIED COMPLETE WITH SCREWS, SEALS AND PLUGS (USE A FLUID SEAL)

DIAPHRAGM - UDP/ISO1D

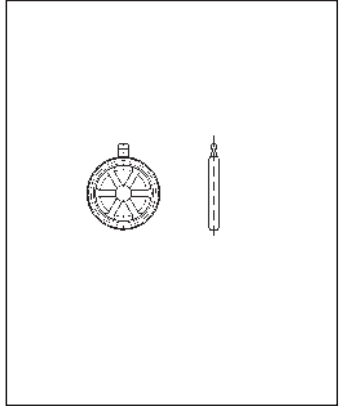

DIAPHRAGM - UDP/ISO2D

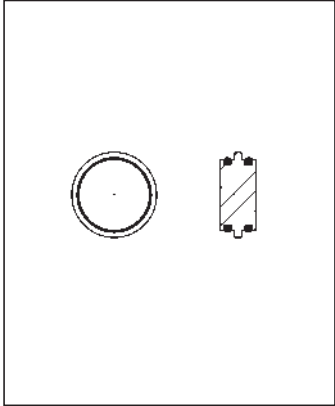

SIZE ADAPTER ISO 1-2 - UDP/ISODT1-2

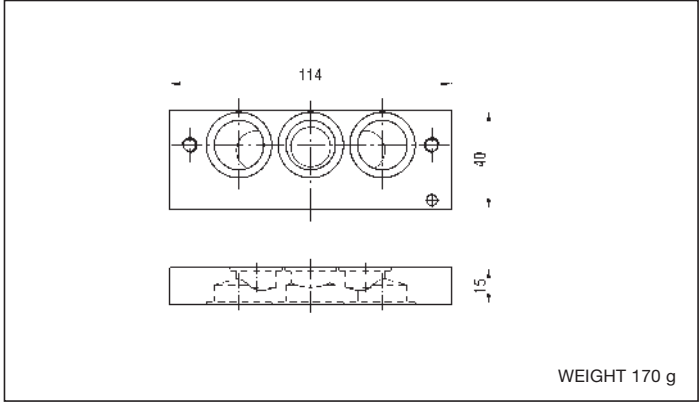

WEIGHT 170 g

SIZE ADAPTER IS SUPPLIED COMPLETE WITH SCREWS AND SEALS

INPUT PLATE - UDP/ISO2PE

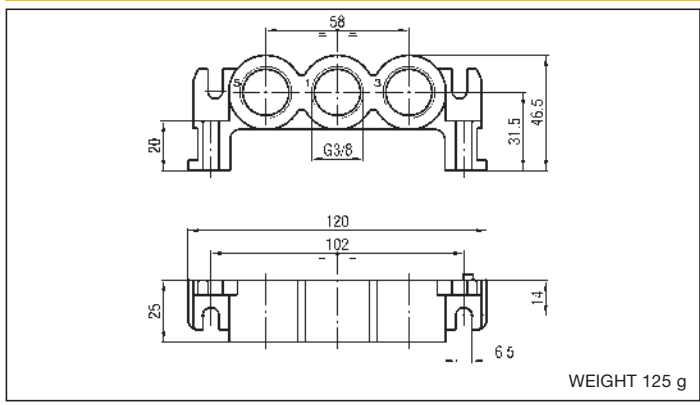

WEIGHT 125 g

INPUT PLATE IS SUPPLIED COMPLETE WITH SCREWS AND SEALS

BLIND TERMINAL PLATE - UDP/ISO2PT

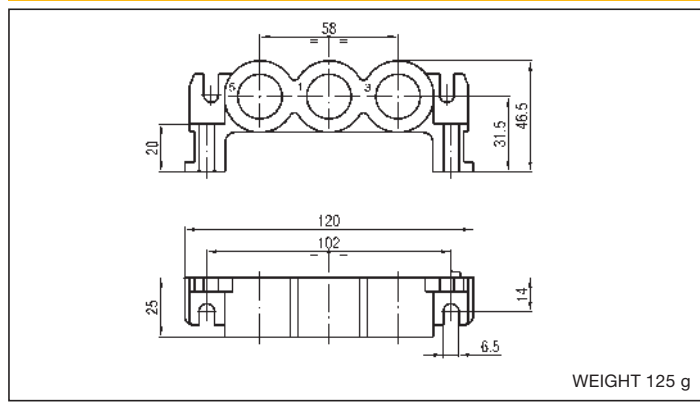

WEIGHT 125 g

UNIVERSAL PLATE

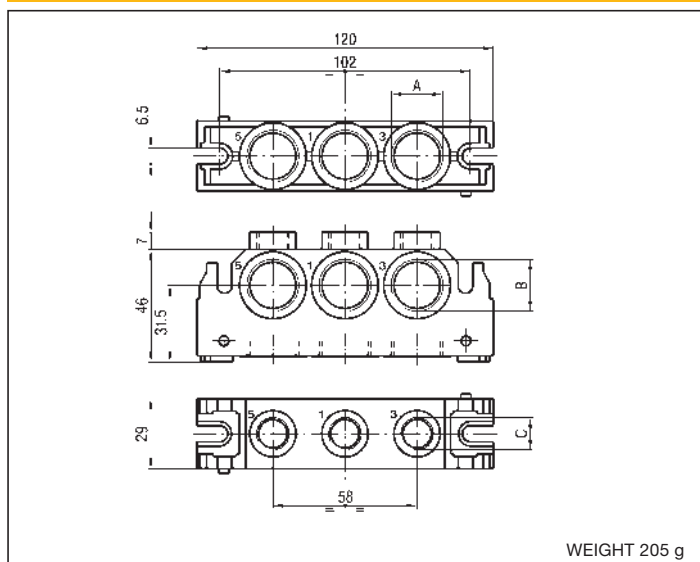

WEIGHT 205 g

DESCRIPTION	A	B	C	TYPE
Intermediate plate, bottom ported	G 1/2	-	-	UDP/ISO2PUI
Intermediate plate, side ported	-	G 1/2	-	UDP/ISO2PUL
Intermediate plate, top ported	-	-	G 1/4	UDP/ISO2PUS
Intermediate plate with blind holes	G 1/2	G 1/2	G 1/4	UDP/ISO2PU

PLATES ARE SUPPLIED COMPLETE WITH SCREWS AND SEALS

MANIFOLD BASE, SIDE AND BOTTOM PORTED - UDP/ISO2BM

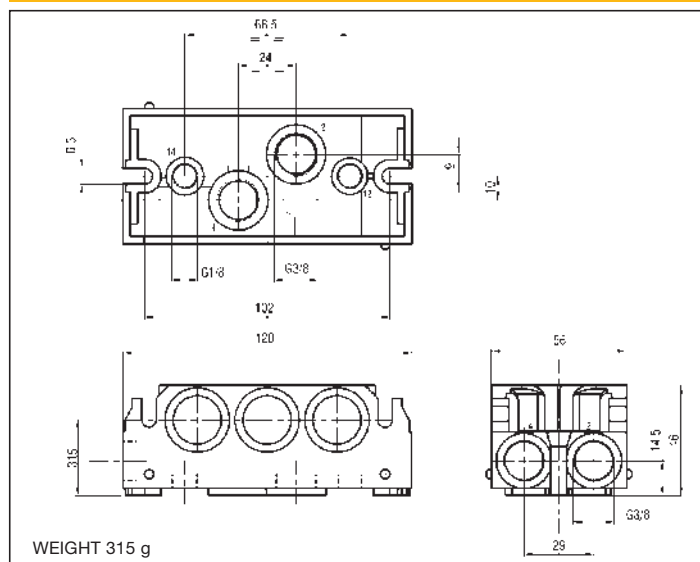

WEIGHT 315 g

MANIFOLD BASE IS SUPPLIED COMPLETE WITH SCREWS, SEALS AND PLUGS (USE A FLUID SEAL)

EXAMPLE OF ASSEMBLY

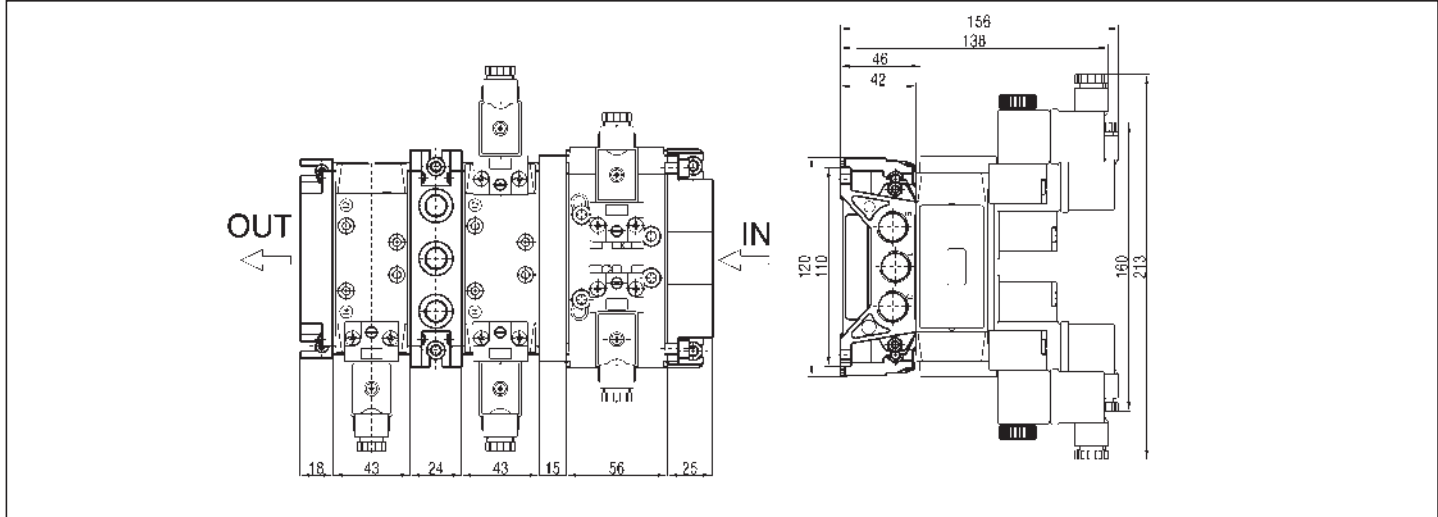

DESCRIPTION

Valves series "UDS CETOP" are produced in the 5/2 and 5/3 pneumatic functions according to the interface to ex CETOP RP 32 P standard and they are mounted onto single bases, bottom or side ported, or onto manifold bases, bottom ported.

All the solenoid actuated versions support the 32 mm direct acting solenoid valve type ULCSV/R (with fixed position) or the amplifier valve type XVF4 for a sensible pneumatic piloting (see page 3.36).



2

TECHNICAL DATA

Operating pressure	Monostable: 2,5 ÷ 10 bar Bistable: 2 ÷ 10 bar
Working temperature	0 ÷ +70 °C (-20 °C with dry air)
Fluid	Filtered, unlubricated or continuous lubricated compressed air
Port size	Interface to ex CETOP RP 32 P standard
Pneumatic piloting port size	Interface to ex CETOP RP 32 P standard
Piloting solenoid valve	ULCSV/R - see chapter Direct acting solenoid valves on page 2.6
Pneumatic piloting valve	XVF4 - see chapter Complementary valves on page 3.37
Electric connector	ULR1B - see chapter Connectors on page 2.15

MATERIALS

Bottoms	Anodized aluminium alloy
Body	Anodized aluminium alloy
Distance rings	Acetal resin
Springs	Galvanized steel
Seals	NBR rubber + steel insert
Spool	Anodized aluminium alloy
Piston	Anodized aluminium alloy

SPARE PARTS

SEALS KIT	
Size 05	UDS/SG/05
Size 12	UDS/SG/12
Size 35	UDS/SG/35

FLOW CHART SIZE 05

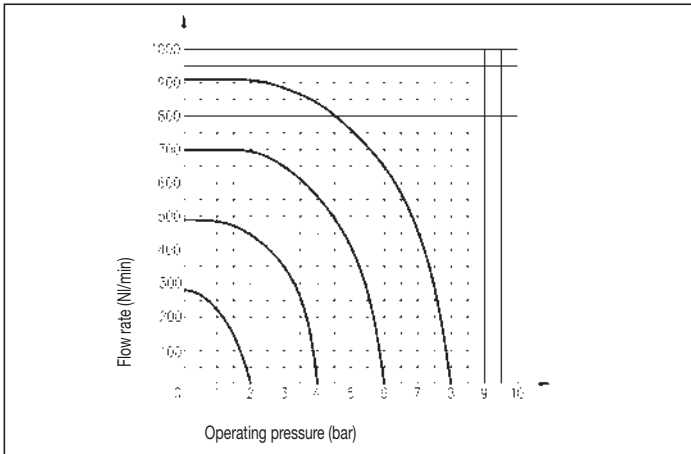

PILOTING CHART SIZE 05

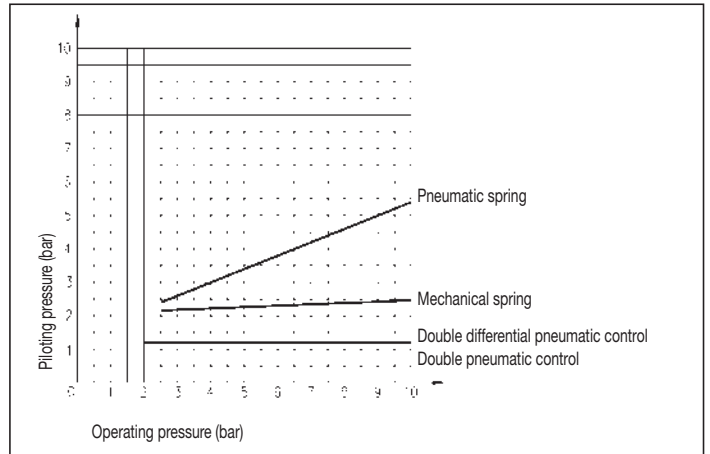

FLOW CHART SIZE 12

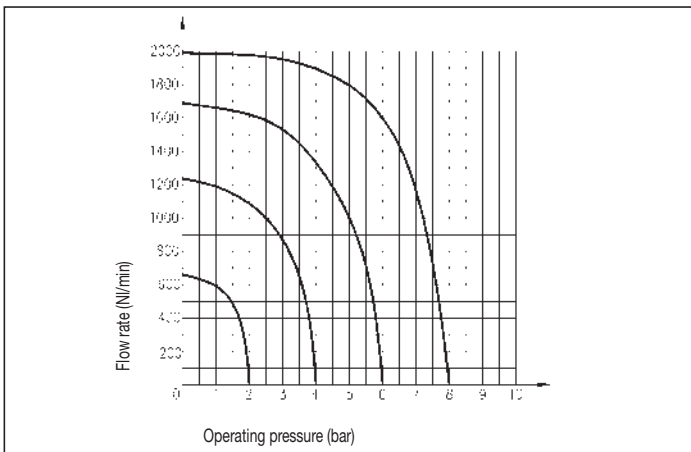

PILOTING CHART SIZE 12

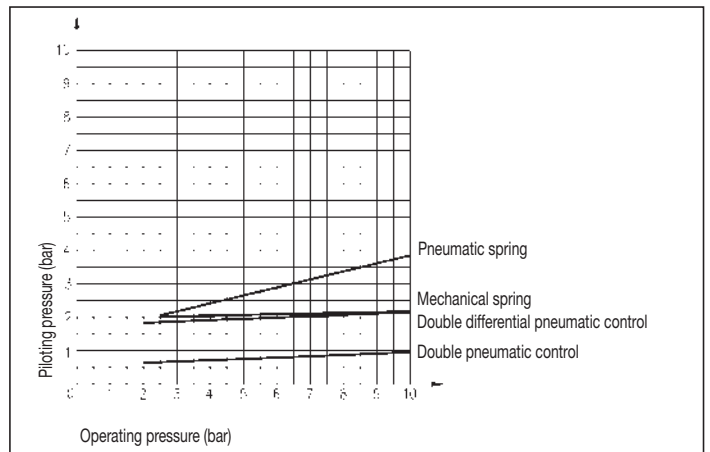

FLOW CHART SIZE 35

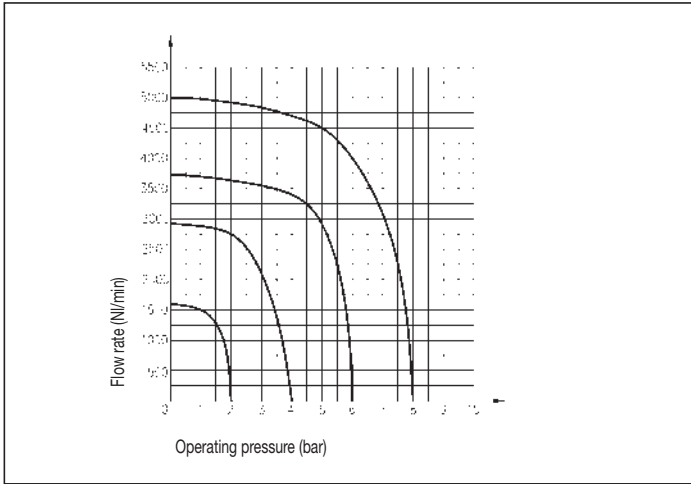

PILOTING CHART SIZE 35

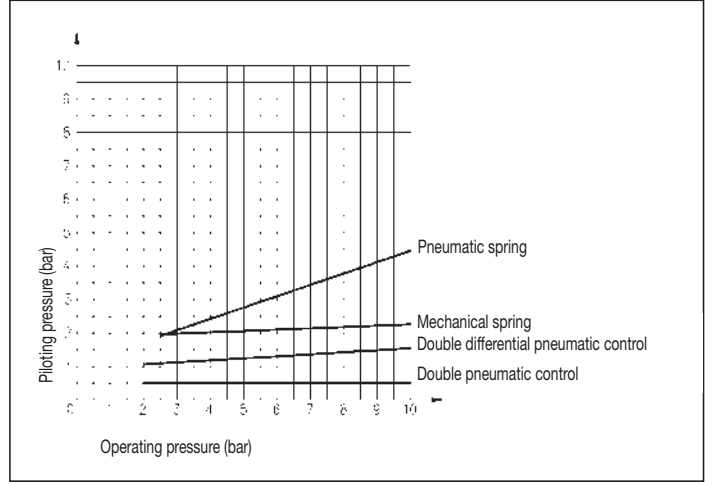

PILOT ACTUATED VALVES* SIZES 05 - 12 - 35

Symbol	Function	Controls		Response times at 6 bar (ms)		Flow rate at 6 bar $\Delta P = 1$ bar (Nl/min)	Weight (g)	Size	TYPE
		Pilot	Return	Energized	De-energized				
	5/2 monostable	Pneumatic	Mechanical spring	29	38	415	310	05	UDS 05 KR/ZR
				30	48	950	760	12	UDS 12 KR/ZR
				42	41	2800	1945	35	UDS 35 KR/ZR
		Mechanical spring	Pneumatic	29	38	415	310	05	UDS 05 ZR/KR
				30	48	950	760	12	UDS 12 ZR/KR
				42	41	2800	1945	35	UDS 35 ZR/KR
	5/2 monostable	Pneumatic	Pneumatic spring	42	34	415	325	05	UDS 05 KR/TQ
				44	59	950	770	12	UDS 12 KR/TQ
				69	71	2800	1900	35	UDS 35 KR/TQ
		Pneumatic spring	Pneumatic	42	34	415	325	05	UDS 05 TQ/KR
				44	59	950	770	12	UDS 12 TQ/KR
				69	71	2800	1900	35	UDS 35 TQ/KR
	5/2 bistable	Pneumatic	Pneumatic	27	27	415	305	05	UDS 05 KR/KR
				28	28	950	745	12	UDS 12 KR/KR
				36	36	2800	1910	35	UDS 35 KR/KR
		Pneumatic	Pneumatic differential	27	27	415	310	05	UDS 05 KR/TR
				28	28	950	770	12	UDS 12 KR/TR
				36	36	2800	1900	35	UDS 35 KR/TR
	Pneumatic differential	Pneumatic	27	27	415	310	05	UDS 05 TR/KR	
			28	28	950	770	12	UDS 12 TR/KR	
			36	36	2800	1900	35	UDS 35 TR/KR	
	5/3 closed centre	Pneumatic	Mechanical spring	30	34	315	325	05	UDS 05 SR/SR
				42	33	815	790	12	UDS 12 SR/SR
				27	31	2650	1980	35	UDS 35 SR/SR

* FOR THE LOW PRESSURE PILOT ACTUATED VALVES OBTAINABLE WITH "XVF4" SEE THE TABLE SOLENOID ACTUATED VALVES ON PAGE 2.88

5 PORT

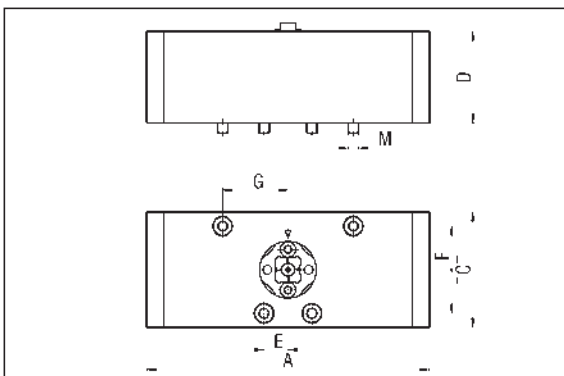

SIZE	A	C	D	E	F	G	M
05	104	38	30	9	26	24	M4
12	130	53	42	11	40	30	M5
35	208	68	52	20	48	54	M8

series UDS CETOP

SOLENOID ACTUATED VALVES SIZES 05 - 12 - 35

Symbol	Function	Controls		Response times at 6 bar (ms)		Flow rate at 6 bar $\Delta P = 1$ bar (Nl/min)	Weight (g)	Size	TYPE*
		Actuation	Return	Energized	De-energized				
	5/2 monostable	Solenoid	Mechanical spring	29	38	415	310	05	UDS 05 KUC/ZR
				30	48	950	765	12	UDS 12 KUC/ZR
				47	39	2800	1970	35	UDS 35 KUC/ZR
		Mechanical spring	Solenoid	29	38	415	310	05	UDS 05 ZR/KUC
				30	48	950	765	12	UDS 12 ZR/KUC
				47	39	2800	1970	35	UDS 35 ZR/KUC
		Solenoid pilot assisted	Mechanical spring	29	38	415	310	05	UDS 05 KUR/ZR
				30	48	950	765	12	UDS 12 KUR/ZR
				47	39	2800	1970	35	UDS 35 KUR/ZR
		Mechanical spring	Solenoid pilot assisted	29	38	415	310	05	UDS 05 ZR/KUR
				30	48	950	765	12	UDS 12 ZR/KUR
				47	39	2800	1970	35	UDS 35 ZR/KUR
		Solenoid	Pneumatic spring	42	34	415	325	05	UDS 05 KUC/TQ
				44	59	950	785	12	UDS 12 KUC/TQ
				76	49	2800	1940	35	UDS 35 KUC/TQ
	Pneumatic spring	Solenoid	42	34	415	325	05	UDS 05 TQ/KUC	
			44	59	950	785	12	UDS 12 TQ/KUC	
			76	49	2800	1940	35	UDS 35 TQ/KUC	
	Solenoid	Pneumatic	27	27	415	305	05	UDS 05 KUC/KR	
			28	28	950	745	12	UDS 12 KUC/KR	
			36	36	2800	1910	35	UDS 35 KUC/KR	
	Pneumatic	Solenoid	27	27	415	310	05	UDS 05 KR/KUC	
			28	28	950	765	12	UDS 12 KR/KUC	
			36	36	2800	1910	35	UDS 35 KR/KUC	
	Solenoid pilot assisted	Pneumatic	27	27	415	310	05	UDS 05 KUR/KR	
			28	28	950	765	12	UDS 12 KUR/KR	
			36	36	2800	1910	35	UDS 35 KUR/KR	
	Pneumatic	Solenoid pilot assisted	27	27	415	310	05	UDS 05 KR/KUR	
			28	28	950	765	12	UDS 12 KR/KUR	
			36	36	2800	1910	35	UDS 35 KR/KUR	
	5/2 bistable	Solenoid	Solenoid	27	27	415	305	05	UDS 05 KUC/KUC
				28	28	950	745	12	UDS 12 KUC/KUC
				36	36	2800	1910	35	UDS 35 KUC/KUC
		Solenoid pilot assisted	Solenoid pilot assisted	27	27	415	305	05	UDS 05 KUR/KUR
				28	28	950	745	12	UDS 12 KUR/KUR
				36	36	2800	1910	35	UDS 35 KUR/KUR
		Solenoid	Small pneumatic	27	27	415	315	05	UDS 05 KUC/TR
				28	28	950	775	12	UDS 12 KUC/TR
				36	36	2800	1900	35	UDS 35 KUC/TR
		Small pneumatic	Solenoid	27	27	415	315	05	UDS 05 TR/KUC
				28	28	950	775	12	UDS 12 TR/KUC
				36	36	2800	1900	35	UDS 35 TR/KUC
		Solenoid pilot assisted	Small pneumatic	27	27	415	315	05	UDS 05 KUR/TR
				28	28	950	775	12	UDS 12 KUR/TR
				36	36	2800	1900	35	UDS 35 KUR/TR
	Small pneumatic	Solenoid pilot assisted	27	27	415	315	05	UDS 05 TR/KUR	
			28	28	950	775	12	UDS 12 TR/KUR	
			36	36	2800	1900	35	UDS 35 TR/KUR	
	5/3 closed centre	Solenoid	Mechanical spring	30	34	315	325	05	UDS 05 SUC/SUC
				42	33	815	795	12	UDS 12 SUC/SUC
				34	38	2650	1980	35	UDS 35 SUC/SUC
Solenoid pilot assisted		Mechanical spring	30	34	315	325	05	UDS 05 SUR/SUR	
			42	33	815	795	12	UDS 12 SUR/SUR	
			34	38	2650	1980	35	UDS 35 SUR/SUR	

* THE TYPES OF THE SOLENOID VALVES DO NOT INCLUDE THE PILOTING SOLENOID VALVES (SEE ON PAGE 2.6 FOR "ULCSV/R") WHEREAS USING AS PILOT THE VALVE "XVF4" THE RESULT IS A LOW PRESSURE PILOT ACTUATED VALVE (FOR "XVF4" - SEE ON PAGE 3.37)

5 PORT MONOSTABLE

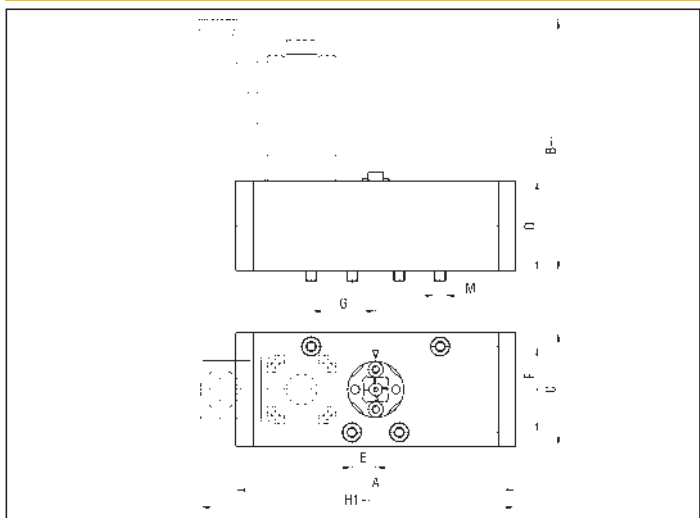

5 PORT AND 3 POSITIONS BISTABLE

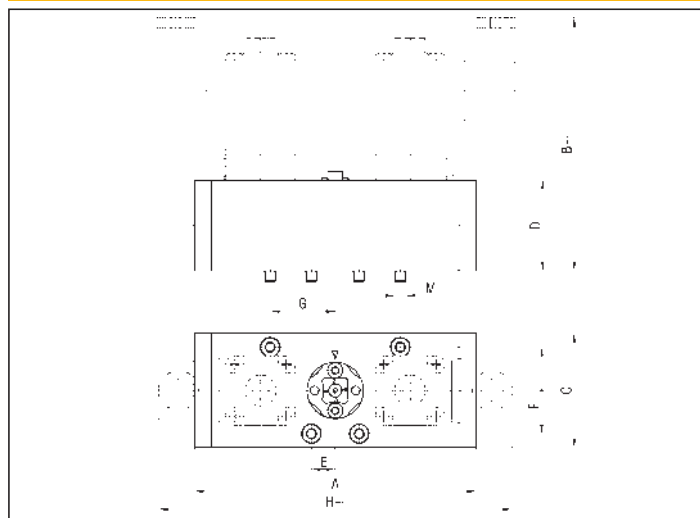

SIZE	A	B	C	D	E	F	G	H	H1	M
05	104	105	38	30	9	26	24	135	120	M4
12	130	117	53	42	11	40	30	158	144	M5
35	208	127	68	52	20	58	54	233	221	M8

SINGLE BASE, BOTTOM PORTED - UDP..B

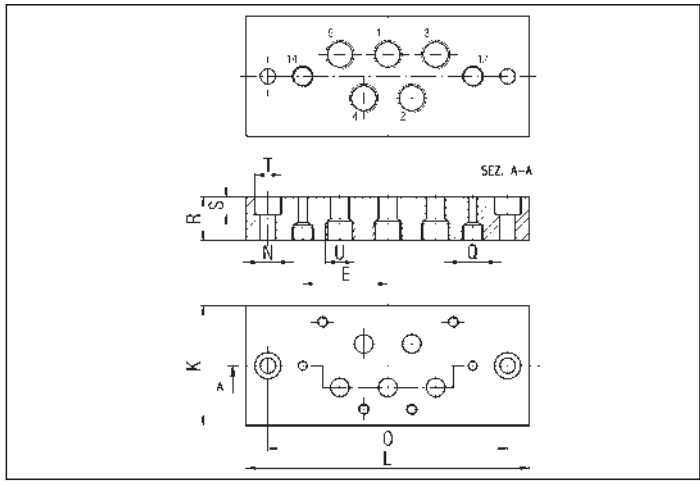

SINGLE BASE, SIDE PORTED - UDP..S

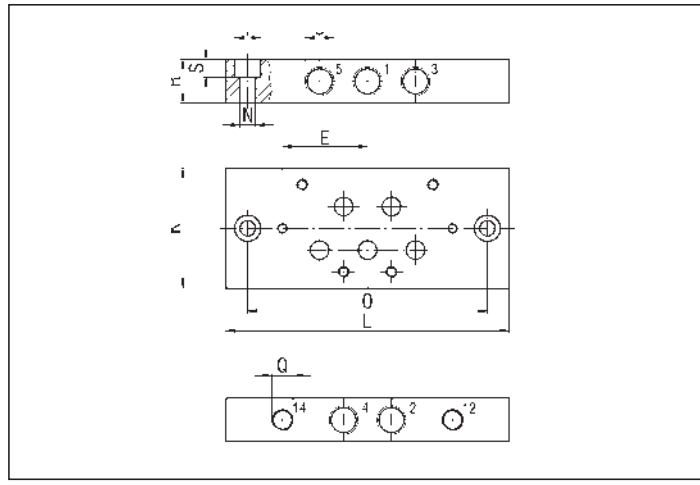

SIZE	Weight (g)	TYPE	Weight (g)	SIZE	E	K	L	N	O	Q	R	S	T	U
UDP8B	170	UDP8S	160	05	30	40	105	6	90	G 1/8	16	6,5	10	G 1/8
UDP4B	365	UDP4S	340	12	39	55	130	7	110	G 1/8	20	8	12	G 1/4
UDP2B	1170	UDP2S	1125	35	65	70	208	9	180	G 1/8	32	11	15	G 1/2

MANIFOLD BASES, BOTTOM PORTED - UDP...M/

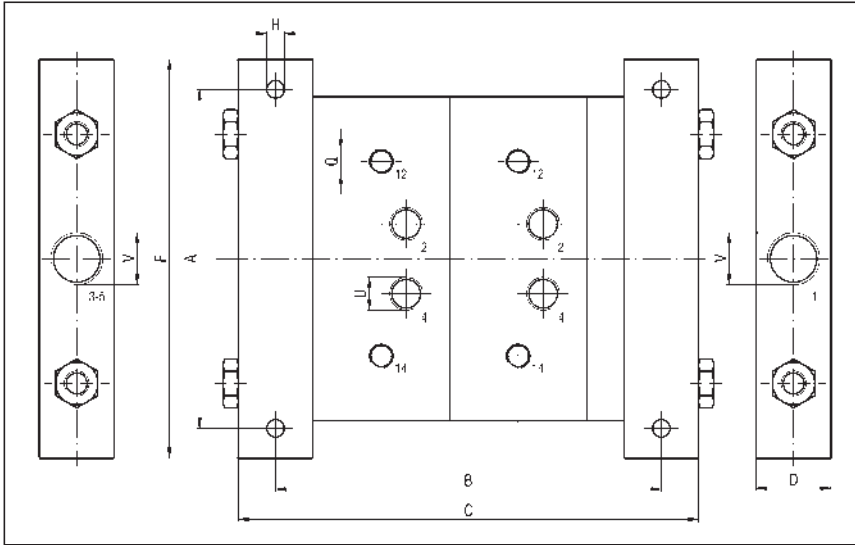

SIZE	A	D	F	H	Q	U	V
05	110	30	130	6	G 1/8	G 1/8	G 1/4
12	136	40	160	7	G 1/8	G 1/4	G 1/2
35	210	50	240	9	G 1/8	G 1/2	G 3/4

No. of stations	2	3	4	5	6	7	8	9	10
B	115	155	195	235	275	315	355	395	435
C	150	190	230	270	310	350	390	430	470
Weight (g)	1165	1480	1795	2110	2425	2740	3055	3370	3685
TYPE Size 05	UDP8M/2	UDP8M/3	UDP8M/4	UDP8M/5	UDP8M/6	UDP8M/7	UDP8M/8	UDP8M/9	UDP8M/10
B	155	210	265	320	375	430	485	540	595
C	197	252	307	362	417	472	527	582	63
Weight (g)	2340	3040	3740	4440	5140	5840	6540	7240	7940
TYPE Size 12	UDP4M/2	UDP4M/3	UDP4M/4	UDP4M/5	UDP4M/6	UDP4M/7	UDP4M/8	UDP4M/9	UDP4M/10
B	170	240	310	380	-	-	-	-	-
C	236	306	376	446	-	-	-	-	-
Weight (g)	5680	7240	9000	10760					
TYPE Size 35	UDP2M/2	UDP2M/3	UDP2M/4	UDP2M/5	-	-	-	-	-

DESCRIPTION

The solenoid valves series "W" can be directly actuated, servo-assisted or with mixed actuation. These solenoid valves, produced in the 2/2 N.C. pneumatic function, are used in several industrial fields, thanks to their compatibility with a large range of fluids.

TECHNICAL DATA

Operating pressure	(See tables below)
Working temperature range	NBR -10 ÷ +90 °C EPDM < +140 °C FPM -10 ÷ +130 °C
Fluid	(See technical information)
Port size	G 1/8 ÷ G 2
Coils	WE3A - see on page 2.93 WE2A - see on page 2.93 WE5A - see on page 2.93
Electric connectors	USR102/N9 - see chapter Connectors on page 2.15 ULR1B - see chapter Connectors on page 2.15

MATERIALS

Body	Brass
Sleeve	Brass
Moving core	Stainless steel
Springs	Stainless steel
Seals	NBR EPDM FPM

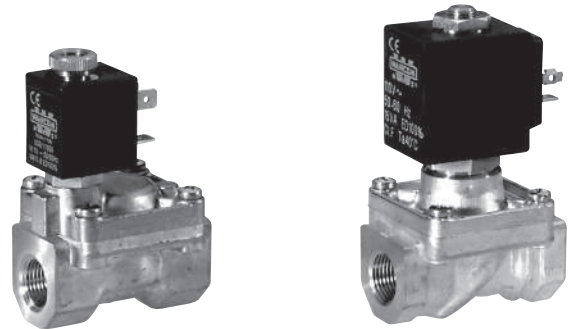

2

TECHNICAL INFORMATION

Seal type	Duty field
NBR	Water max. 70 °C, air max. 90 °C, mineral oils and derivatives - hydrocarbons (methane, ethane, propane, butane, kerosene and gas oil)
EPDM	Hot water and steam max. 140 °C, detergents, solutions of sodium and potassium, hydraulic fluids and polar solvents (not to be used with mineral oils and grease)
FPM (Viton®)	For general purpose max. 130 °C

Calculation of the flow rate

For liquids	$Q = K_v \sqrt{\frac{\Delta p}{\rho}}$
For gases	$Q_n = 26 K_v \sqrt{\Delta p P}$
Kv =	Flow coefficient
Q = m³/h	Flow rate
Qn = m³/h	Normal flow rate (20 °C and 760 mm Hg)
P = bar	Absolute downstream pressure
Δp = bar	Pressure drop (differential pressure between the upstream and downstream pressure)
ρ = Kg/dm³	Specific gravity (ratio of density of the substance to the density of water at 4°C)

2 PORT G 1/8 - DIRECTLY ACTUATED

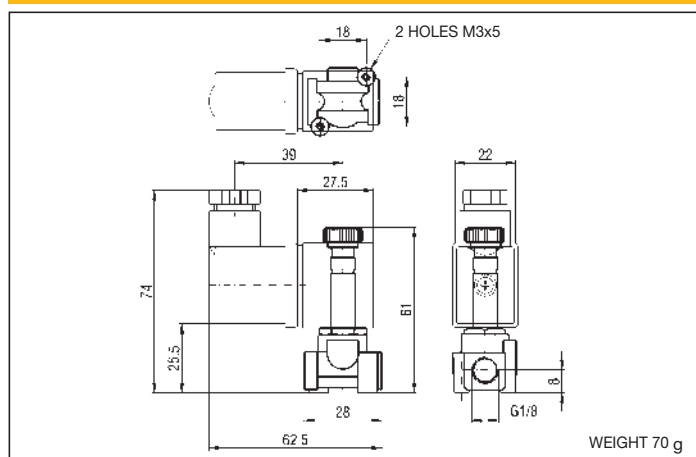

Symbol	Function	Differential pressure (bar)		Kv	Nominal orifice (mm)	Port size	TYPE**	
		MIN.	MAX.					
		AC	DC					
	2/2 N.C.	0	25	25	0,04	1,2	G 1/8	W 105 1 * E3A
		0	16	16	0,06	1,5	G 1/8	W 105 2 * E3A
		0	12	10	0,09	2	G 1/8	W 105 3 * E3A
		0	8	5,5	0,14	2,5	G 1/8	W 105 4 * E3A
		0	5	2	0,19	3,1	G 1/8	W 105 5 * E3A

* SPECIFY THE SEALING TYPE: B = NBR; V = FPM; E = EPDM

** THE TYPES OF THE SOLENOID VALVES DO NOT INCLUDE COILS (SEE "WE3A" ON PAGE 2.93)

2 PORT G 1/8 - G 1/4 DIRECTLY ACTUATED

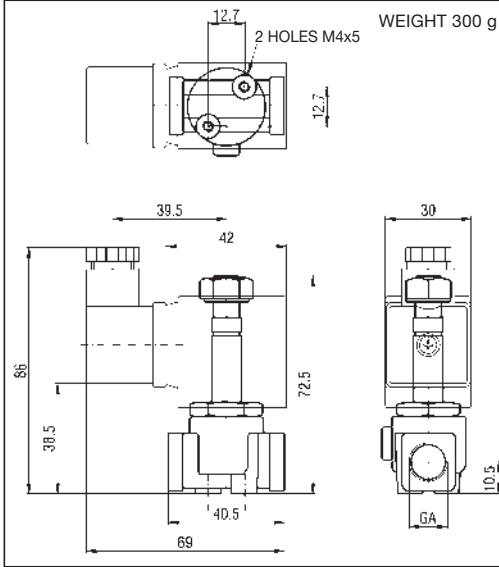

Symbol	Function	Differential pressure (bar)		Kv	Nominal orifice (mm)	Port size (GA)	TYPE**	
		MIN.	MAX.					
			AC					DC
	2/2 N.C.	0	30	26	0,07	1,5	G 1/8	W106 1 * E2A
		0	22	20	0,1	2	G 1/8	W106 2 * E2A
		0	16	14	0,15	2,5	G 1/8	W 106 3 * E2A
		0	10	8	0,32	3,5	G 1/8	W 106 4 * E2A
		0	30	26	0,07	1,5	G 1/4	W 106 5 * E2A
		0	22	20	0,1	2	G 1/4	W 106 6 * E2A
		0	16	14	0,15	2,5	G 1/4	W 106 7 * E2A
		0	10	8	0,32	3,5	G 1/4	W 106 8 * E2A
		0	6,5	3,5	0,41	4,5	G 1/4	W 106 9 * E2A
		0	4	1,8	0,47	5,2	G 1/4	W 106 10 * E2A
		0	-	1	0,64	6,4	G 1/4	W 106 11 * E2A

* SPECIFY THE SEALING TYPE: B = NBR; V = FPM; E = EPDM

** THE TYPES OF THE SOLENOID VALVES DO NOT INCLUDE COILS (SEE "WE2A" ON PAGE 2.93)

2 PORT G 3/8 - G 2 SERVO ASSISTED

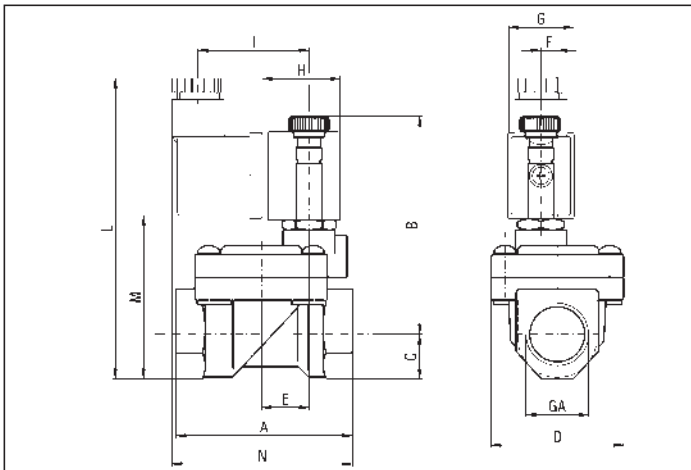

Symbol	Function	Differential pressure (bar)			Kv	Nominal orifice (mm)	Port size (GA)	TYPE**
		MIN.	MAX.					
			AC	DC				
	2/2 N.C.	0,15	15	15	2	12	G 3/8	W 107 1 * E3A
		0,15	15	15	2,2	12	G 1/2	W 107 2 * E3A
		0,15	13	13	5,2	18	G 3/4	W 107 3 * E3A
		0,15	10	10	10,2	24	G 1	W 107 4 * E3A
		0,15	10	10	18	37	G 1 1/4	W 107 5 * E2A
		0,15	10	10	21	37	G 1 1/2	W 107 6 * E2A
		0,15	10	10	36	50	G 2	W 107 7 * E2A

* SPECIFY THE SEALING TYPE: B = NBR, V = FPM, E = EPDM

** THE TYPES OF THE SOLENOID VALVES DO NOT INCLUDE COILS (SEE "WE2A" AND "WE3A" ON PAGE 2.93) THAT HAVE PREFERABLY TO BE MOUNTED TOWARD THE HIGH

GA	A	B	C	D	E	F	G	H	I	L	M	N	WEIGHT (g)
G 3/8	60	70	14	45	16	6	22	27,5	39	102	53,5	62,5	450
G 1/2	60	70	14	45	16	6	22	27,5	39	102	53,5	62,5	450
G 3/4	75	74	18	55	20	8,5	22	27,5	39	108	59,5	66	660
G 1	96	85	20	72	32	-	22	27,5	39	120	71,5	64,5	1200
G 1 1/4	144	107	28	102	45	-	30	42	39,5	128	79,5	75,5	3200
G 1 1/2	144	107	28	102	45	-	30	42	39,5	128	79,5	75,5	2900
G 2	152	116,5	35	119	48	-	30	42	39,5	159	110,5	76,5	4500

2 PORT G 3/8 - G 1 WITH MIXED ACTUATION

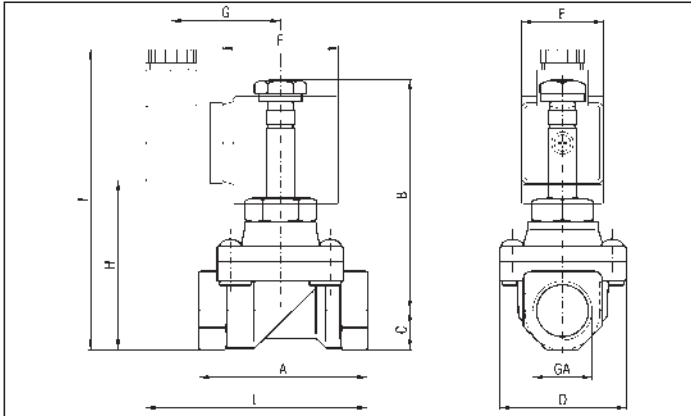

GA	A	B	C	D	E WE2A	E WE5A	F WE2A	F WE5A
G 3/8	59	83	14	45	30	36	42	47,5
G 1/2	59	83	14	45	30	36	42	47,5
G 3/4	79	90	18	55	-	36	-	47,5
G 1	96	101	20	72	-	36	-	47,5

G WE2A	G WE5A	H WE2A	H WE5A	I WE2A	I WE5A	L WE2A	L WE5A	WEIGHT (g)
39,5	42,5	58,5	58	106	105,5	79	82	580
39,5	42,5	58,5	58	106	105,5	79	82	530
-	42,5	-	69	-	116,5	-	89,5	750
-	42,5	-	82	-	129,5	-	100	1200

Symbol	Function	Differential pressure (bar)			Kv	Nominal orifice (mm)	Port size (GA)	TYPE**
		MIN.	MAX.					
			AC	DC				
	2/2 N.C.	0	10	-	2	12	G 3/8	W 108 1 * E2A
		0	10	-	2,2	12	G 1/2	W 108 2 * E2A
		0	12	10	2	12	G 3/8	W 108 1 * E5A
		0	12	10	2,2	12	G 1/2	W 108 2 * E5A
		0	9	-	4,5	18	G 3/4	W 108 3 * E5A
		0	7	-	8,5	24	G 1	W 108 4 * E5A

* SPECIFY THE SEALING TYPE: B = NBR; V = FPM; E = EPDM

** THE TYPES OF THE SOLENOID VALVES DO NOT INCLUDE COILS (SEE "WE2A" AND "WE3A") THAT HAVE PREFERABLY TO BE MOUNTED TOWARD THE HIGH

COIL TYPE WE3A

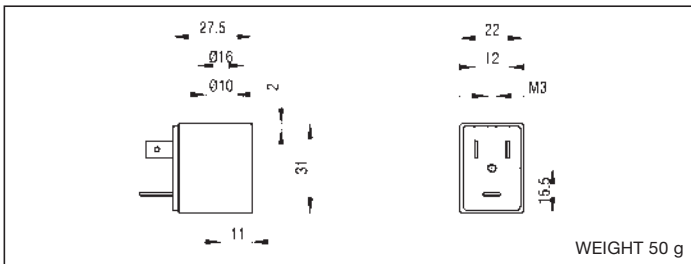

Power consumption	DC: 5,5 W AC: 11 VA (inrush)
-------------------	---------------------------------

DESCRIPTION	TYPE
COIL 22 mm 24 V DC	WE3A/02400
COIL 22 mm 24 V AC	WE3A/02450-60
COIL 22 mm 110 V AC	WE3A/11050-60
COIL 22 mm 220 V AC	WE3A/22050-60

ELECTRIC CONNECTOR "USR 102/N9" (SEE ON PAGE 2.15)

COIL TYPE WE2A

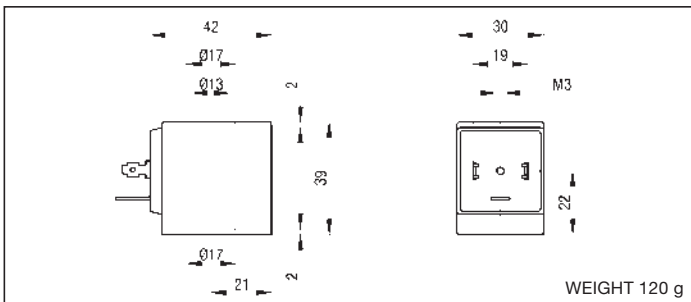

Power consumption	DC: 8 W AC: 20 VA (inrush)
-------------------	-------------------------------

DESCRIPTION	TYPE
COIL 30 mm 24 V DC	WE2A/02400
COIL 30 mm 24 V AC	WE2A/02450-60
COIL 30 mm 110 V AC	WE2A/11050-60
COIL 30 mm 220 V AC	WE2A/22050-60

ELECTRIC CONNECTOR "ULR1B" (SEE ON PAGE 2.15)

COIL TYPE WE5A

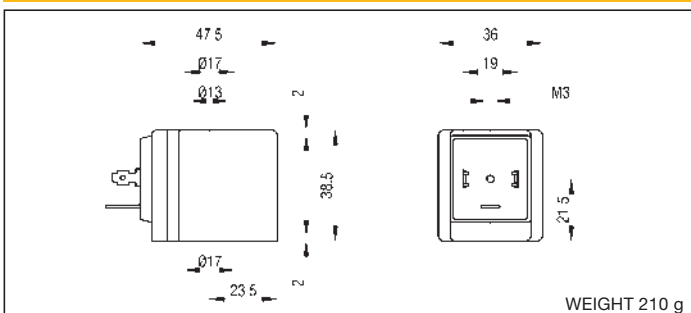

Power consumption	DC: 23 W AC: 40 VA (inrush)
-------------------	--------------------------------

DESCRIPTION	TYPE
COIL 36 mm 24 V DC	WE5A/02400
COIL 36 mm 24 V AC	WE5A/02450-60
COIL 36 mm 110 V AC	WE5A/11050-60
COIL 36 mm 220 V AC	WE5A/22050-60

ELECTRIC CONNECTOR "ULR1B" (SEE ON PAGE 2.15)

DESCRIPTION

Valves for vacuum series "EV" are produced only in the 3/2 N.O. and 3/2 N.C. pneumatic functions with solenoid pilot assisted actuation.

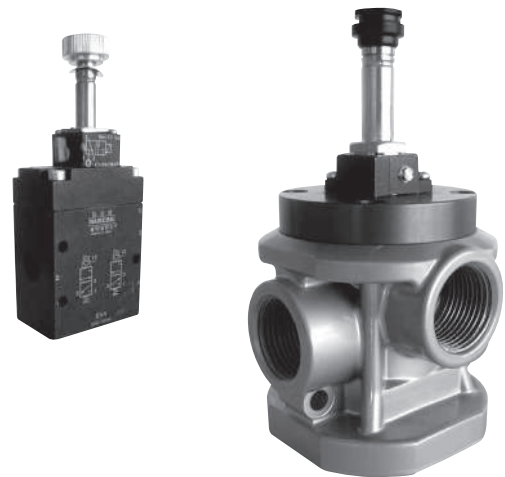

TECHNICAL DATA

Maximum vacuum	755 mm Hg
Pneumatic piloting pressure	3 ÷ 10 bar
Working temperature	-20 ÷ +40°C
Fluid	Vacuum
Port size	G 1/8 - G 1/4 - G 3/8 - G 1/2 - G 3/4 - G 1 - G 1 1/2 - G 2
Coils	G 1/8: WE3A - see Coils on page 2.93 G 1/4 - G 3/8: USB - see chapter Coils on page 2.14 G 1/2 ÷ G 2: WE2A - see Coils on page 2.93
Electric connectors	USR102/N9 - see chapter Connectors on page 2.15 ULR1B - see chapter Connectors on page 2.15

MATERIALS

Bottoms	Anodized aluminium
Body	Anodized aluminium
Springs	Stainless steel
Sleeve	Nickel-plated brass
Core	Stainless steel
Piston	Aluminium
Diaphragm and plunger	Polyurethane

3 PORT SOLENOID PILOT ASSISTED ACTUATED VALVES

Symbol	Function	Controls		Response times at 6 bar (ms)		Maximum flow rate pump (m3/h)	Port size	Size	TYPE**
		Actuation	Return	Energized	De-energized				
	3/2 N.C. - 3/2 N.O.*	Solenoid pilot assisted	Mechanical spring	15	25	1,5	G 1/8	163	EV8
	3/2 N.C. - 3/2 N.O.*			18	28	4	G 1/4	462	EV4
	3/2 N.C. - 3/2 N.O.*			18	28	10	G 3/8	451	EV3
	3/2 N.C. - 3/2 N.O.*			20	40	20	G 1/2	780	EV2
	3/2 N.C. - 3/2 N.O.*			20	40	20	G 3/4	750	EV6
	3/2 N.C. - 3/2 N.O.*			20	45	90	G 1	1212	EV1
	3/2 N.C. - 3/2 N.O.*			60	40	180	G 1 1/2	3300	EV12
	3/2 N.C. - 3/2 N.O.*			80	50	250	G 2	9800	EV16

* FOR VERSION N.O. ARRANGE THE CONNECTIONS AS INDICATED: 1 = EXHAUST
2 = OUTPUT
3 = PUMP

**THE TYPES OF THE SOLENOID VALVES DO NOT INCLUDE COILS

EV8 - EV4 - EV3

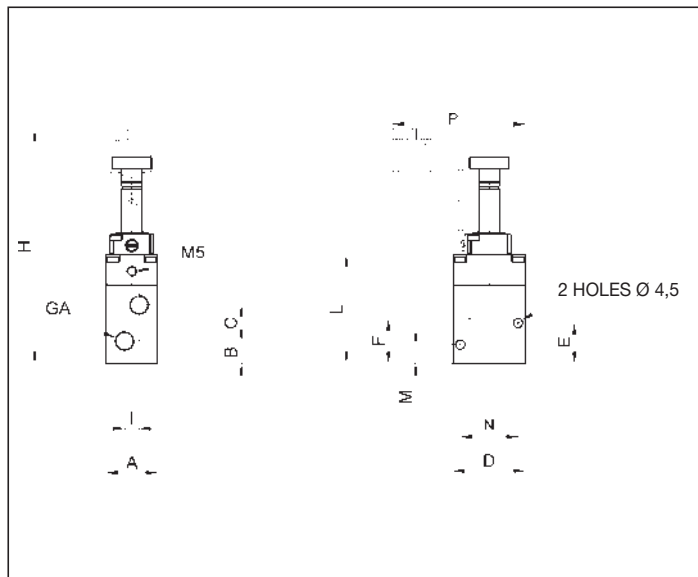

TYPE	A	B	C	D	E	F	GA	H	I	L	M	N	P
EV8	25	11	17.5	35	19.7	21.7	G 1/8	112.7	7	52.7	9.2	28	65
EV4	32	24	23.5	59	36	36	G 1/4	136	-	74.5	24.5	40	89
EV3	32	24	23.5	59	36	36	G 3/8	136	-	74.5	24.5	40	89

EV2 - EV6 - EV1 - EV12 - EV16

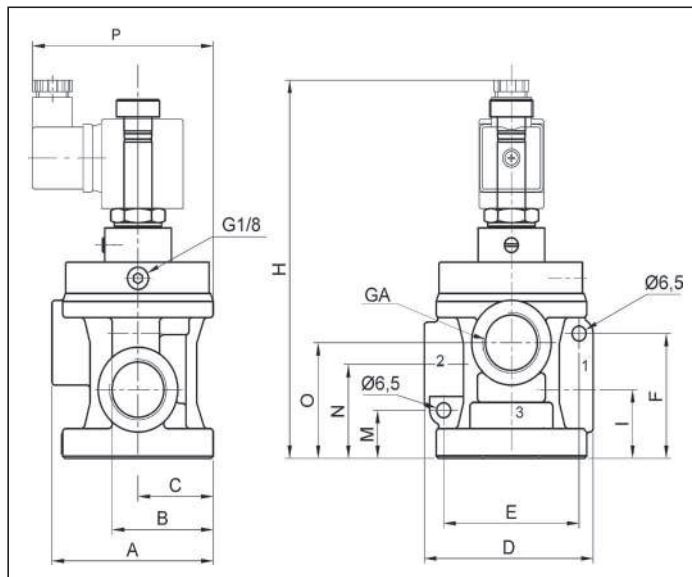

TYPE	A	B	C	D	E	F	GA	H	I	M	N	O	P
EV2	75	47	35	78.5	63	54.5	G 1/2	152	30	21	41	50.5	85.5
EV6	75	47	35	78.5	63	54.5	G 3/4	152	30	21	41	50.5	85.5
EV1	94	55	45	101	78	62.5	G 1	168	38	25.5	51	64	95
EV12	138	84	59	158	113	113	G 1½	240	68	34	68	96	-
EV16	183.5	113.5	78.5	210	150	152	G 2	310	92	48	92	129	-

DESCRIZIONE

Valves series "VM" generate vacuum using the Venturi effect. These valves found a specific employment in the aspiration from single work points with a suction cap.



2

TECHNICAL DATA

Operating pressure	1 ÷ 10 bar
Fluid	Vacuum
Feeding fluid	Compressed air
Port size	G 1/8 - G 1/4 - G 3/8 - G 1/2 - G 3/4 - G 1
Nominal diameter	1,5 mm
Max. vacuum capability	0,7 bar

MATERIALS

Body	Anodized aluminium alloy
Nozzle	Brass
Seals	NBR rubber

SUCTION CHART

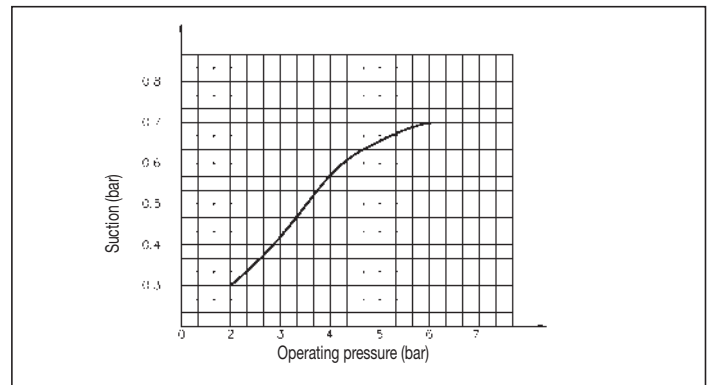

DIMENSIONS AND WEIGHT VM

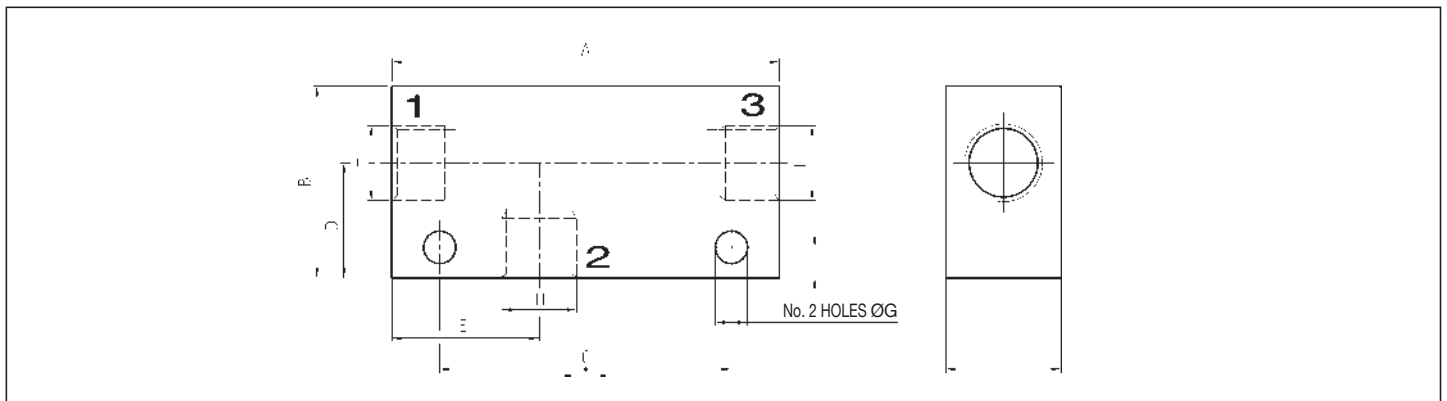

1 = FEEDING FLUID
2 = SUCTION
3 = EXHAUST

Symbol	A	B	C	D	E	F	G	I	H	L	WEIGHT (g)	TYPE
	50.5	25	38	15	19.2	4	4.2	15	G 1/8	G 1/8	50	VM8
	58	30	38	19.5	23	4	4.2	25	G 1/4	G 1/4	90	VM4
	71.5	30	52	18.5	31	4.5	5.2	25	G 3/8	G 3/8	146	VM3
	75	35	56	21	33	4.5	5.2	30	G 1/2	G 1/2	203	VM2
	90.5	50	61.5	28.5	49.4	4.5	5.2	50	G 3/4	G 1/4	692	VM15
	97	50	68	28.5	52.4	4.5	5.2	50	G 1	G 1/4	643	VM1