



Circuit Boards and Clippard Modular Components

Clippard clear acrylic pneumatic circuit boards are designed to provide a compact and highly efficient pneumatic control system, with the use of Clippard modular components and other Clippard products.



Many valving systems require a considerable amount of piping, tubing and fittings to create the necessary circuitry. The piping originates beneath the valve and often needs extra space and clearance to complete. The acrylic circuit board provides a place to mount the components and easy methods to hook-up the circuit, generally on the top side of the circuit board. For a single circuit the original assembly method can be the best direction

to take... but where a number of identical circuits are prepared, the acrylic circuit board technology offers a series of distinct advantages.

In addition to the Clippard modular line of products, the circuit boards also accommodate Clippard EV/ET manifold mount valves, and many other valves, gauges, mufflers, as well as hose barb fittings. The combination of Clippard pneumatic circuit boards, valves, fittings, and accessory items can provide a complete pneumatic circuit system with the knowledge of dependability and success.

FEATURES

- Custom-made pneumatic circuit boards hold all components
- Simplifies assembly
- Reduces piping
- Helps assure accuracy of connections
- Component I.D. silk-screened on subplate surface
- Inputs and outputs clearly marked
- Threaded brass inserts hold components securely
- Change valves quickly without affecting connections
- Use any number of components
- Makes sophisticated circuitry manageable
- Circuit boards also accept Clippard electronic interface valves
- Saves assembly costs

Pneumatic Circuit Boards

This section provides detailed information about a series of circuit boards for popular uses. These range from the very simple single-module circuit, to more complex multi-step sequencing circuits using pneumatic control to automate machine or process cycles. The descriptive materials include photographs, dimensional drawings, circuit diagrams where applicable, lists of products required, and descriptions of the function of the circuit.

The circuit boards included in our price list are maintained in stock with our distributors and/or in our finished goods inventory at our factory. They are available for fast delivery.



For assistance in selecting a circuit board to suit your use, ask your local Clippard distributor to discuss your application.



PNEUMATIC MODULES

Custom Pneumatic Circuit Boards

You can have a faster, more dependable way to produce multiples of the same pneumatic circuit . . . a system that enables you to speed circuit assembly while assuring accurate hookups.

Using Clippard modular components, valves and controls mounted on a custom circuit board, you get the same circuit time after time.

Assembly time and effort are reduced. A large number of parts, fittings, and lengths of tubing are no longer needed. The resulting circuit is compact, neat in appearance,

and can be easily mounted for permanent installation. No more “haywire” plumbing. Piping errors are eliminated, and an efficient, dependable, and attractive control results.

Each custom circuit board is individually produced with the same high quality standards associated with the Clippard name. By utilizing Clippard’s unique manufacturing process, these clear acrylic units provide sealed internal passageways between valves without the need for gaskets, clamps, or piping.

Sizes and dimensions will vary according to your application. By adapting your control requirements to the versatility of Clippard Modular Valves, your Clippard distributor can provide you with detailed application information.

To complete your pneumatic control, just plug in the modular valves and tighten the two captivated screws on each valve. Connect inputs and outputs to the circuit board and the circuit is ready to run. It’s the fastest most efficient circuit system available.



Alternate Valve Configurations for Pneumatic Modules

In order to gain maximum functionality of these circuits, Clippard provides alternate valves that alter the characteristic of the circuit.

In general:

As an alternate valve to the [R-402](#), the [R-412](#) provides automatic reset function. When supply air is removed from the [R-412](#), a reset spring positions the valve element so that when the air is re-applied, the actuator will go to its “home” position.

The [VA-06](#), [VA-031](#) and [VA-033](#) pneumatic modules sense pressure decay when the actuator stops moving. The standard valve for sensing this stop is the [R-305](#). The use of an [R-301](#) speeds up the end of stroke turnaround time enabling a faster cycle rate. The [R-343](#) is a time delay which increases the dwell time before the actuator reverses direction.

If any of the above alterations to these circuits are desired, individual components may be selected from the “Bill of Materials” listed on each page. For more information, or a more detailed description of these options, please contact Clippard for assistance.



Binary Redirect Module (“Flip-Flop” Circuit)



Size: 4.50" x 2.75" x 3.50"

Temperature: 32 to 140°F

Pressure Range: 40 to 150 psig

Use: The input signal alternates the outputs A and B, sometimes referred to as a push-on/push-off circuit. The circuit manifold combines the R-451 and R-412 in a binary redirect or flip-flop circuit.

Operation: Use of the R-412 provides a “memory” function to return the output to a known position (port 8) whenever air is first turned on to the circuit. This output pilots port 4 of the R-451, positioning it for the next signal. A signal input passes through the R-451, ports 1 to 2, and pilots port 4 of the R-412. The output of the R-412 shifts to port 2 and also pilots port 6 of the R-451. When the next signal input is received, it passes through the R-451, ports 1 to 8, and pilots port 6 of the R-412, shifting its output back to port 8.

Part No.	Description	
<u>VA-03</u>	Binary Redirect Module	
Bill of Materials in Assembly		
Qty.	Part No.	Description
1	<u>R-451</u>	4-Way Binary Trigger Modular Valve
1	<u>R-412</u>	4-Way Modular with Memory Reset
1	<u>CM-03-PQ</u>	Binary Redirect Circuit Manifold

All components are also available for purchase

The CM-03 subplate is available with 1/8" NPT Ports on A, B, C & D.

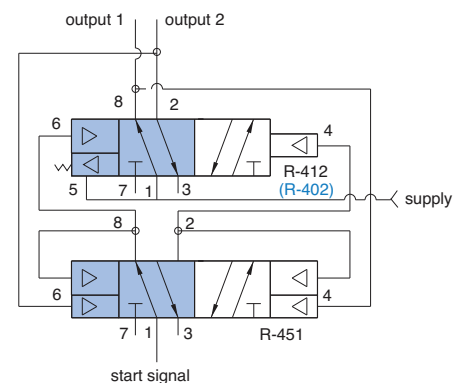
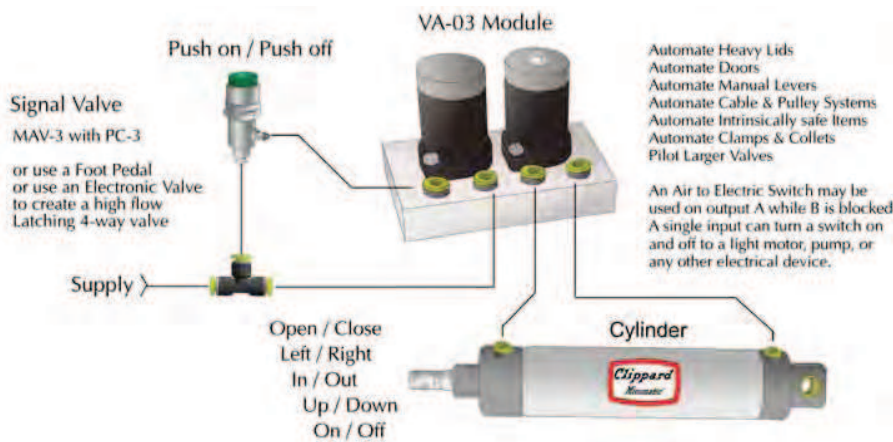
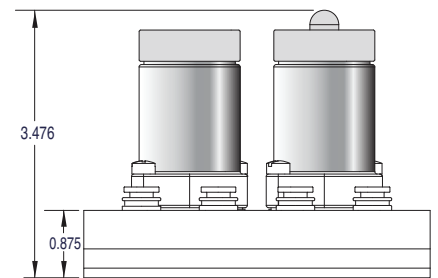
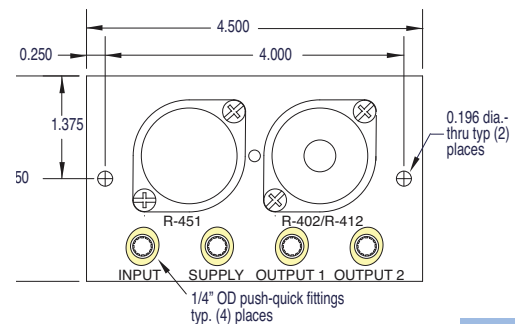

Note: See Page 258 for alternative valve (in parenthesis above).



PNEUMATIC MODULES

Oscillator Module or Auto-Cycling of a Single-Acting Cylinder



Size: 2.50" x 4.00" x 3.50"

Temperature: 32 to 140°F

Pressure Range: 40 to 150 psig

Use: The VA-011 module is designed to use an "on-off" toggle valve (or alternative input) for an oscillating output that can be used to actuate a single-acting cylinder.

Operation: With no start input, the cylinder will remain in retracted position. Turning on the start input signal causes each valve to shift upon the others output signal. The output "on time" can be adjusted for longer or shorter times, and the "off time" is also adjustable.

Part No.	Description
<u>VA-011</u>	Oscillator Module or Auto-Cycling of a Single-Acting Cylinder

Bill of Materials in Assembly		
Qty.	Part No.	Description
2	<u>R-333</u>	3-Way Adjustable Delay Modular Valve
1	<u>CM-011-PQ</u>	Circuit Manifold
10'	<u>URT1-0805-GNT</u>	1/4" O.D. Polyurethane Tubing, Green
5'	<u>URT1-0503-CLR</u>	5/32" O.D. Polyurethane Tubing, Clear

All components are also available for individual purchase

The CM-011 subplate is available with 1/8" NPT and #10-32 threads

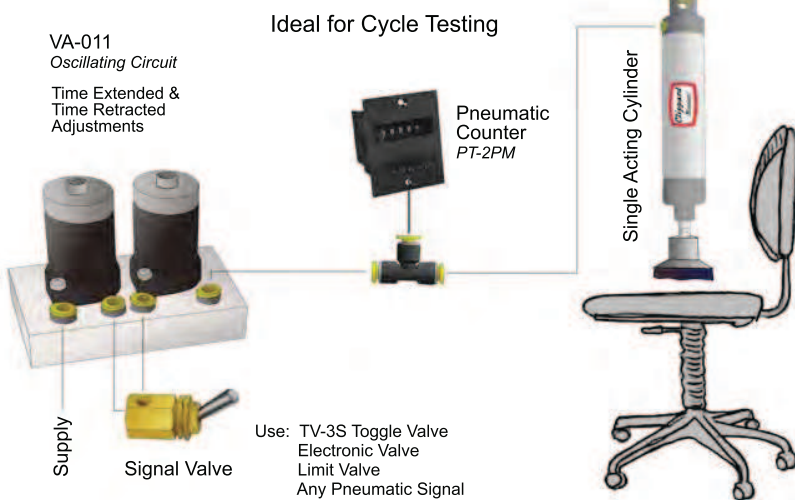
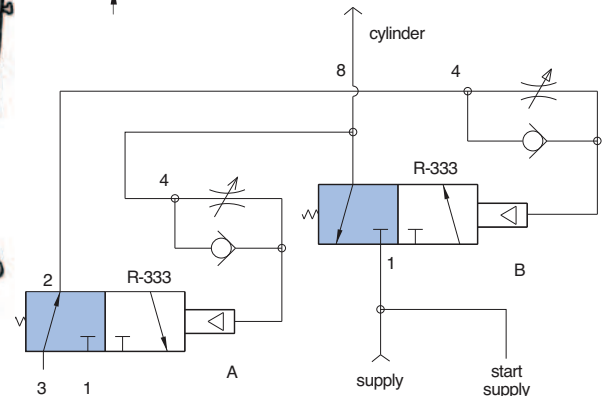
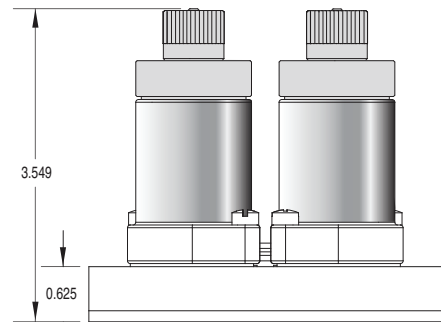
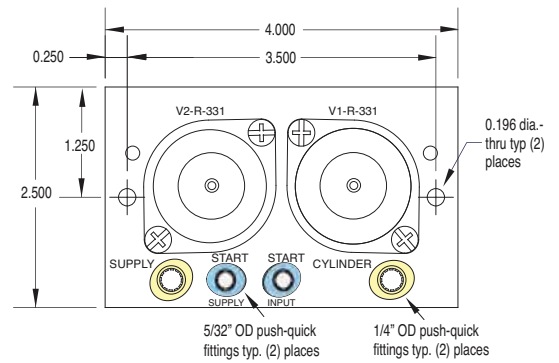

Module for Single Input Clamp Control



Size: 7.00" x 4.00" x 4.00"

Temperature: 32 to 140°F

Pressure Range: 40 to 150 psig

Use: The Clippard VA-08 module uses a single input (from pneumatic foot pedal or button) to provide a simple and clean "OPEN/CLOSE" clamp control with adjustable pressure and speed controls.

The use of the VA-08 package offers special user benefits: saves time; reduces cost and labor of piping; automates product tasks with easy-to-apply unit; binary push button operation; speed control built-in; pressure regulation included; may be operated remotely; equipped with "Auto-Reset" feature so when supply is turned on, the clamp will always go to the open position.

Part No.	Description
VA-08	Module Only
VA-08-FP	Module with Foot Pedal Actuator
VA-08-GN	Module with Green Palm Button

Bill of Materials in Assembly

Qty.	Part No.	Description
1	R-402	4-Way Modular Valve
1	R-412	4-Way Modular Valve with Memory Reset
1	R-451	4-Way Binary Trigger Modular Valve
1	R-701	Regulator
1	CM-08-PQ	Circuit Manifold
2*	PQ-UE08P	1/4" Universal Elbow Push-Quick Fitting
20*	URT1-0805-GNT	1/4" O.D. Polyurethane Tubing, Green
2	MNV-1KP	Miniature Needle Valve
1	PG-101	Pressure Gauge
1*	MMV-F3QM-F	Foot Pedal Actuator
1*	PB-1-GN	Green Palm Button
2	15070	Noise Muffler

* Only on designated Part Numbers as shown below

All components are also available for purchase

The **CM-08** subplate is available with 1/8" NPT threads and no valve assembled

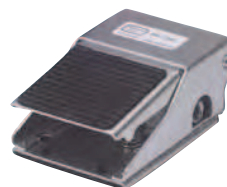
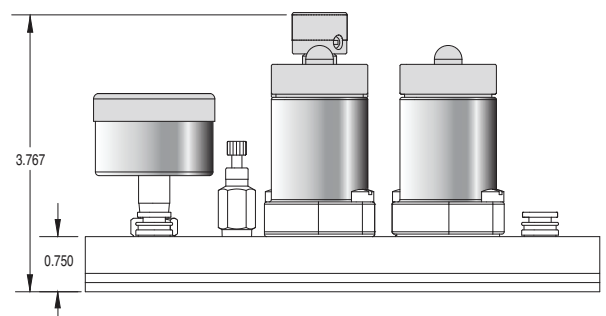
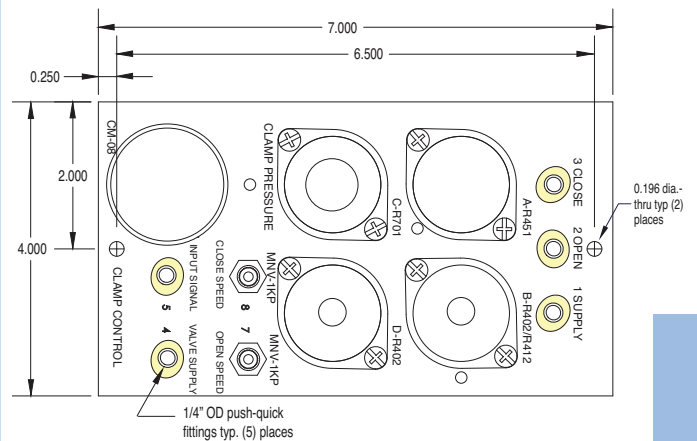
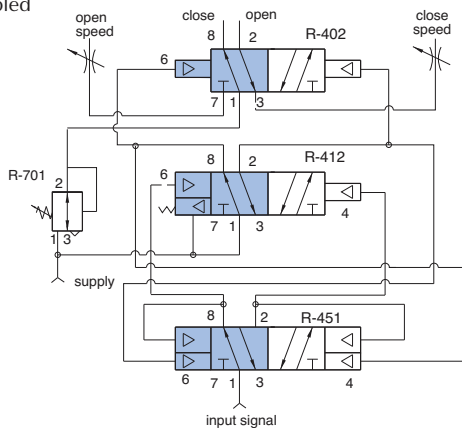

1 Foot Pedal Actuator ([MMV-F3QM-F](#)) and fittings included with Part No. [VA-08-FP](#)

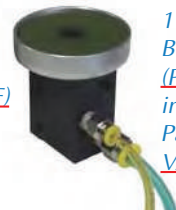

1 Green Palm Button ([PB-1-GN](#)) is included with Part No. [VA-08-GN](#)



PNEUMATIC MODULES

Two-Hand, No-Tie-Down (THNTD) Circuit



Size: 6.25" x 3.50" x 3.25"
Temperature: 32 to 140°F
Pressure Range: 50 to 120 psig
Use: The main function of this control is to require a machine operator to use both hands at the same time to actuate the equipment, helping to insure that the operator's hands are not in a position to be injured by the machine as it is in motion.
Operation: Clippard's Minimatic® VA-023 circuit module is a self-contained modular circuit board with all interconnections required to provide a Two-Hand, No-Tie-Down (THNTD) pneumatic circuit. Use of the VA-023 will assure simple and rapid installation of your Two-Hand, No-Tie-Down circuit.

Part No.	Description
VA-023	THNTD Circuit without Palm Buttons
VA-023-GN	THNTD Circuit with Green Palm Buttons
VA-023-RD	THNTD Circuit with Red Palm Buttons

Bill of Materials in Assembly

Qty.	Part No.	Description
1	R-315	3-Way Modular Multi-Piloted Valve
2	R-401	4-Way Modular Valve
1	CM-023-PQ	THNTD Circuit Manifold
2*	PB-1-GN	Green Palm Button with (2) 1/4" Push-Quick Fittings
2*	PB-1-RD	Red Palm Button with (2) 1/4" Push-Quick Fittings
10'	URT1-0805-GNT	1/4" O.D. Polyurethane Tubing, Green
4"	URT1-0503-YLT	5/32" O.D. Polyurethane Tubing, Yellow
4*	PQ-UE08P	1/4" Universal Elbow Push-Quick Fitting
1	PQ-PG05	5/32" Push-Quick Plug

* Comes with "-GN" and/or "-RD" options only
 All components are also available for purchase
 The [CM-023](#) subplate is available with 1/8" NPT ports on A, B, C & D, and #10-32 threads for Ports E & F

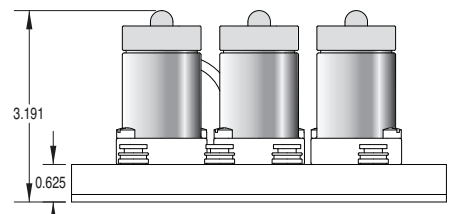
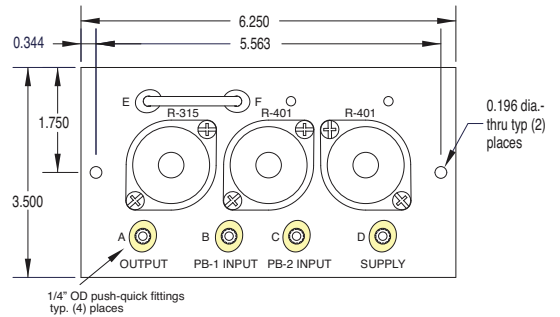

(2) Green Palm Buttons
 ([PB-1-GN](#)) are included
 with Part No. [VA-023-GN](#)

 (2) Red Palm Buttons
 ([PB-1-RD](#)) are included
 with Part No. [VA-023-RD](#)

Limited Warranty

When properly used, this equipment meets ANSI B11.1-1971 and OSHA 1910.217 safety standards for Two-Hand, No-Tie-Down controls. It is the buyer's sole responsibility to determine proper application, location installation, use and maintenance of this equipment. This equipment performs the function of a Two-Hand, No-Tie-Down control only. All other prescribed safety devices must be used with this equipment. Seller shall not be responsible for any failure to so comply which results from the application, installation, location, operation, use or maintenance of this equipment or from alteration of the equipment by persons other than the seller, or from design or instruction furnished by the buyer or his agents. Sellers liability shall be limited to replacement or modification of the equipment to comply with OSHA standards or to refund the purchase price. Seller will be responsible for any fines, penalties or consequential damage. Clippard makes no other warranty of any kind, expressed or implied.

VA-023 & CM-023 Special Features



Maintained Output occurs as long as both palm buttons are held. Release of either button terminates the output (shipped in this configuration).

How: Connect E to F using a piece of 5/32" O.D. tubing as a jumper



Momentary Output gives a single output pulse that is about 50 ms in duration.

How: Plug E with 5/32" Push-Quick Plug (11755 screw plug if using CM-023); F is open



Cancelable Output terminates the output after a Normally-Open 3-way limit valve has been tripped, even if both palm buttons are held.

How: Interpose Normally-Open 3-way valve or other circuit function



Cancel Output after Time Delay is a variation of Cancelable Output (above) where pneumatic delay valve, such as Clippard's Model R-331, is set to cancel the output after a designated time interval has elapsed regardless of how long the buttons are held.

How: Interpose Normally-Open 3-way delay valve (see R-331)



It is the user's responsibility to determine which special feature can be safely used in their particular application. Because of the variety of applications for this equipment, detailed instructions cannot be given for each possible use. Users are warned that improper application, use, installation, maintenance and/or alterations to this product may result in malfunctions and possible damage or injuries. This device, and all equipment and/or machinery associated with it, should be tested weekly by qualified personnel for proper function and operation.

Two-Hand, No-Tie-Down ANSI Circuit

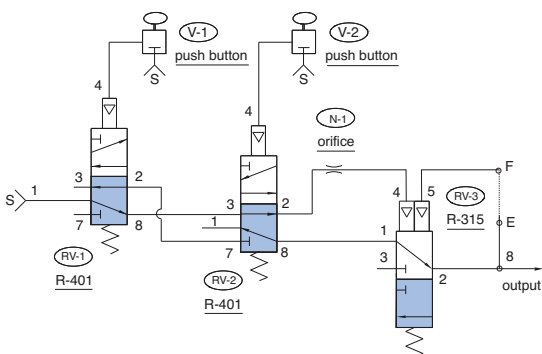

Absolutely no alterations or modifications should be made to this circuit or its components parts.

Circuit Operation:

RV-3 is held open by supply air that passes through RV-1, RV-2 and N-1. When RV-1 is actuated alone, the pilot air for RV-3 flows back through the N-1 and RV-2 to atmosphere at RV-1, and RV-3 is closed by the spring. When RV-2 is actuated alone, the same sequence occurs except the pilot air from RV-3 exhausts to atmosphere via RV-2.

Restriction N-1 determines the time span during which both signals must be received in order to obtain the output. When RV-1 and RV-2 are actuated together, supply air is directed through RV-1, RV-2 and RV-3 to the output, providing a momentary output signal that is determined by N-1. If a maintained signal is required, a jumper between E and F maintains an output as long as the operator is depressing both palm buttons.

The indicator on RV-3 (R-315) must be down for an output to be obtained. If either RV-1 or RV-2 is actuated separately, their respective indicator will go up, but after approximately one second, the indicator on RV-3 (R-315) will go down showing that the valve has shifted and an output cannot be obtained. Circuit performance and sequence should be periodically observed to verify proper function.



PNEUMATIC MODULES

VA-034 Add-On Provides Back Pressure Latch Control



Size: 2.50" x 4.25" x 3.50"

Temperature: 32 to 140°F

Pressure Range: 40 to 150 psig

Use: The VA-034 module is for operation of a clamp or collet system where Two-Hand, No-Tie-Down input is required to be held continuously until the position desired (limit valve) is fully engaged. Two-Hand, No-Tie-Down circuit is re-engaged to release the clamp mechanism.

Operation: Output of the CM-023 or VA-023 goes to the VA-034 module and begins to extend cylinder. The two palm buttons on the Two-Hand, No-Tie-Down must remain actuated until the limit valve is actuated or unit will retract the cylinder. When the cylinder has depressed the limit valve, the unit locks the valve, and the cylinder continues to see pressure on the extend port. The unit is latched and buttons can now be released. A second input from the CM-023 or VA-023 (depressing both buttons) will now release the latch and retract the cylinder to the starting position as shown, and the circuit is ready for another operation.

Part No.	Description
VA-034	Back Pressure Latch Control for VA-023

Bill of Materials in Assembly

Qty.	Part No.	Description
2	R-431	4-Way Twin Pilot Modular Valve
1	CM-034-PQ	Circuit Manifold
10'	URT1-0805-GNT	1/4" O.D. Polyurethane Tubing, Green
5'	URT1-0503-CLR	5/32" O.D. Polyurethane Tubing, Clear

All components are also available for individual purchase

The **CM-034** subplate is available with 1/8" NPT and #10-32 threads

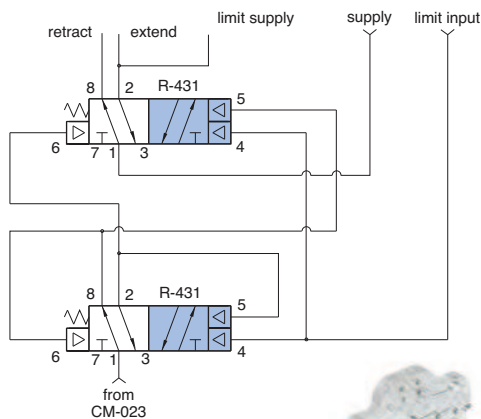
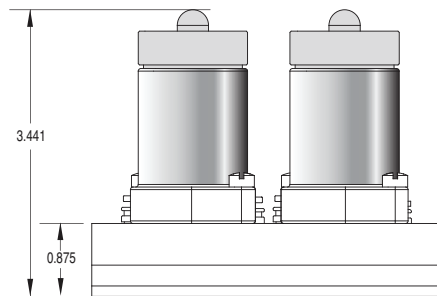
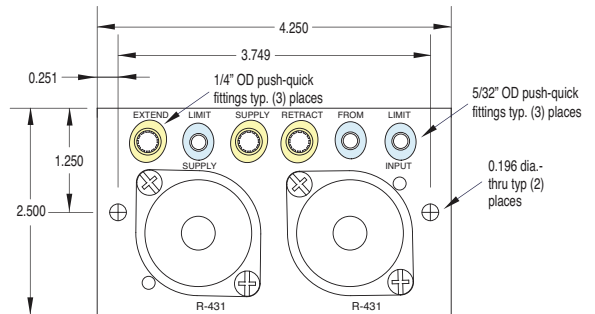

SPEEDY CIRCUIT ASSEMBLY

You can have a faster, more dependable way to produce multiples of the same pneumatic circuit. This system enables speedy assembly while assuring accurate connections. By utilizing Clippard's unique manufacturing process, these clear acrylic subplates provide sealed passageways between valves without the need for gaskets, clamps, or piping. It's the fastest, most efficient circuit system available.

Two-Hand, No-Tie-Down Circuit with Latching Control (Combination of VA-023 & VA-034)



Size: 4.50" x 6.00" x 3.50"

Temperature: 32 to 140°F

Pressure Range: 40 to 150 psig

Use: The VA-038 module is for operation of a clamp or cylinder operation where Two-Hand, No-Tie-Down input is required to be held continuously until the position desired (limit valve) is fully engaged. The Two-Hand, No-Tie-Down circuit releases the latch and returns the cylinder to the retracted position.

Operation: The two palm buttons on the Two-Hand, No-Tie-Down must remain actuated until the limit valve is actuated, or the unit will retract the cylinder. When the cylinder has depressed the limit valve, the unit locks the valve, and the cylinder continues to see pressure on the extend port. The unit is latched, and buttons can now be released. A second input from depressing both buttons will now release the latch and retract the cylinder to the starting position as shown, and the circuit is ready for another operation.

Part No.	Description
VA-038	Module Only without Palm Buttons
VA-038-GN	Module with 2 Green Palm Buttons
VA-038-RD	Module with 2 Red Palm Buttons

Bill of Materials in Assembly		
Qty.	Part No.	Description
2	R-431	4-Way Twin-Pilot Modular Valve
2	R-401	4-Way Modular Valve
1	R-315	3-Way Modular Multi-Piloted Valve
2*	PB-1-GN	Green Palm Button
2*	PB-1-RD	Red Palm Button
1	CM-038-PQ	Circuit Manifold
4	PQ-UE08P	1/4" Universal Elbow Push-Quick Fitting
10'	URT1-0805-GNT	1/4" O.D. Polyurethane Tubing, Green
10'	URT1-0503-CLT	5/32" O.D. Polyurethane Tubing, Clear

* Included in designated Part Numbers only
 All components are also available for individual purchase
 The **CM-038** subplate is available with 1/8" NPT and #10-32 threads

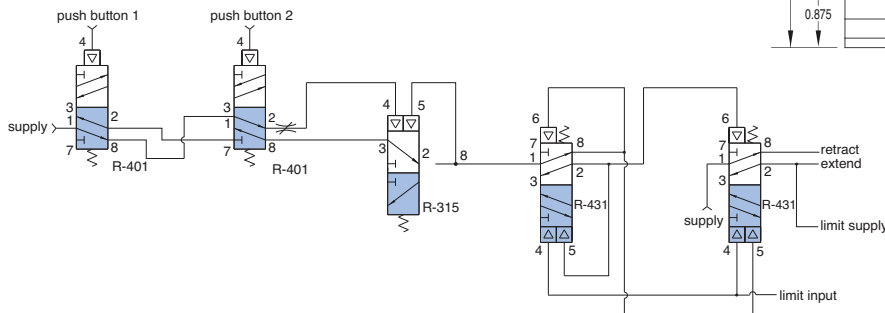
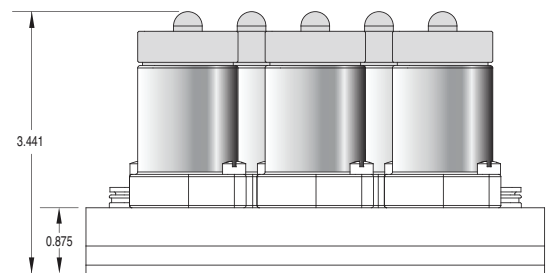
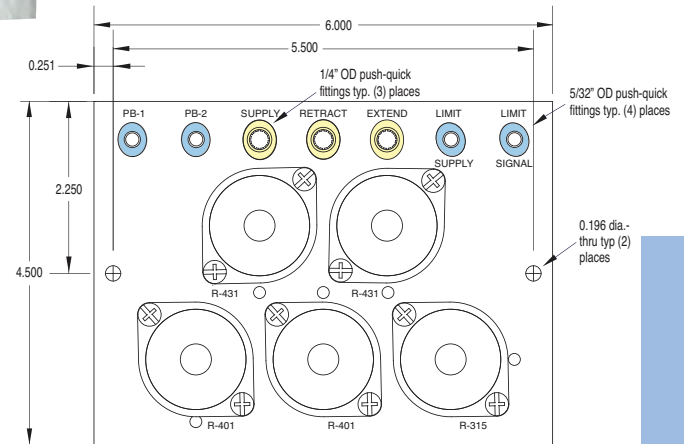

Palm Buttons are included with Part No. VA-038-GN and VA-038-RD



PNEUMATIC MODULES

Auto-Cycling of a Double-Acting Cylinder



Size: 2.75" x 4.25" x 3.25"

Temperature: 32 to 140°F

Pressure Range: 40 to 150 psig

Use: Similar to the VA-06, this is a more compact version designed for automatic cycling of double-acting cylinders without the use of limit valves or a magnetic sensor.

Operation: This circuit enables a double-acting cylinder to reciprocate without the use of limit valves and to control its speed in each direction. The two R-333 and R-453 valves also incorporate adjustable delay features that will control the time between retract and extend cycles.

Part No.	Description
VA-028	Auto-Cycling of a Double-Acting Cylinder

Bill of Materials in Assembly

Qty.	Part No.	Description
1	R-333	3-Way Modular Multi-Piloted Valve
1	R-453	4-Way Modular Valve
1	TV-3S	On-Off Toggle Valve
1	11675-05	Fitting Adapter
1	CM-028-PQ	Circuit Manifold
1	PQ-CC05N	5/32" Male Connector Push-Quick Fitting
4'	URT1-0503-YLT	5/32" O.D. Polyurethane Tubing, Yellow
10'	URT1-0805-GNT	1/4" O.D. Polyurethane Tubing, Green

All components are also available for individual purchase

The **CM-028** subplate is available with 1/8" NPT and #10-32 threads

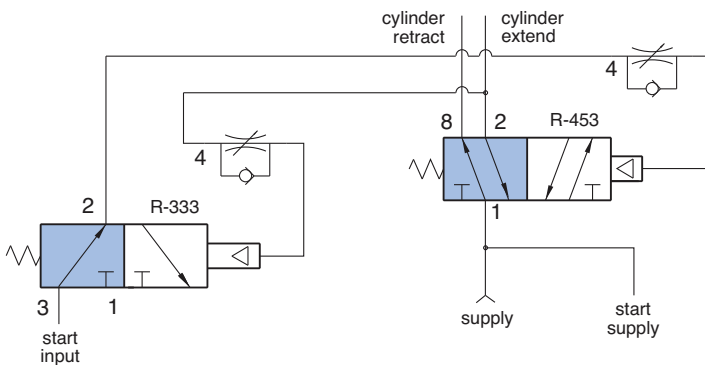
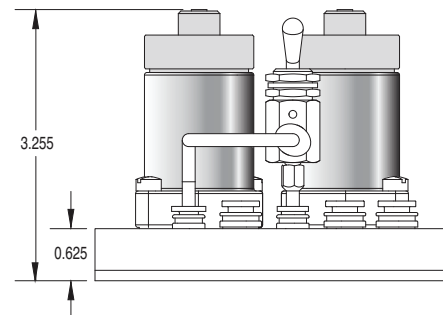
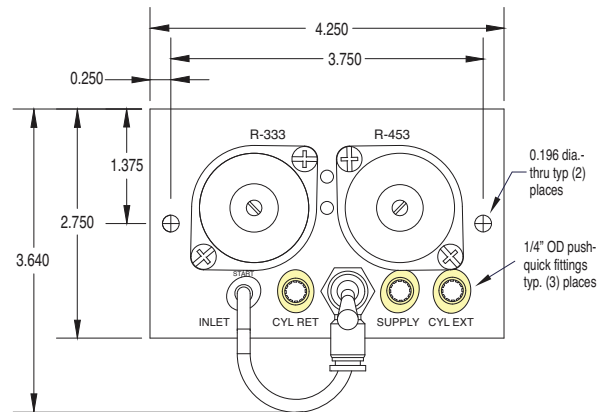



Auto-Cycling of a Double-Acting Cylinder



Size: 6.00" x 3.25" x 3.50"

Temperature: 32 to 140°F

Pressure Range: 40 to 150 psig

Use: The VA-06 module is designed to use an "on-off" toggle valve (or alternative input) for the cycling of a double-acting cylinder without the use of limit valves.

Operation: This circuit enables a double-acting cylinder to reciprocate without the use of limit valves and to control its speed in each direction. The two R-343 valves also incorporate adjustable delay features that will control the time between retract and extend cycles. With the miniature needle valves, the speed of the cylinder is also adjustable for your application.

Part No.	Description
VA-06	Auto-Cycling of a Double-Acting Cylinder

Bill of Materials in Assembly

Qty.	Part No.	Description
2	R-343	3-Way Modular Delay Valve
1	R-412	4-Way Modular Reset Valve
1	TV-3S	On-Off Toggle Valve
1	11675-05	Fitting Adapter
2	MNV-1KP	Miniature Needle Valve
2	15070	Noise Muffler
1	CM-06-PQ	Circuit Manifold
1	PQ-CC05N	5/32" Male Connector Push-Quick Fitting
4"	URT1-0503-YLT	5/32" O.D. Polyurethane Tubing, Yellow
10'	URT1-0805-GNT	1/4" O.D. Polyurethane Tubing, Green

All components are also available for individual purchase

The CM-06 subplate is available with 1/8" NPT and #10-32 threads

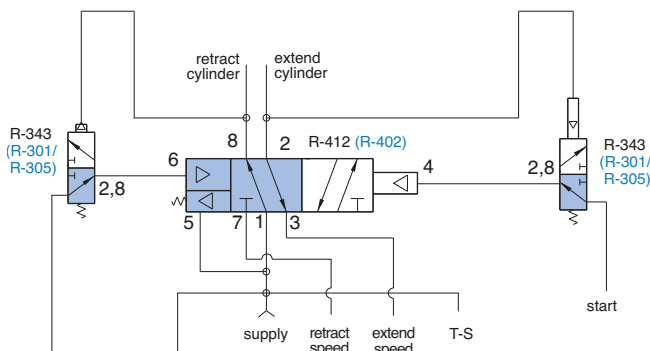

Note: See Pages 248, 249 and 258 for alternative valve(s) (in parenthesis above).

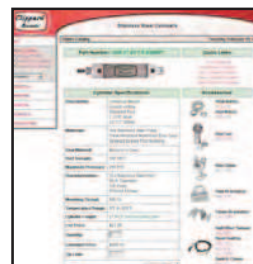
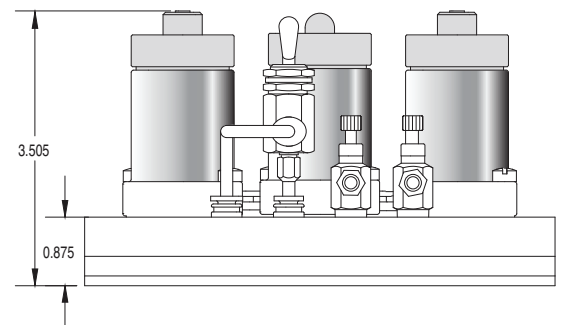
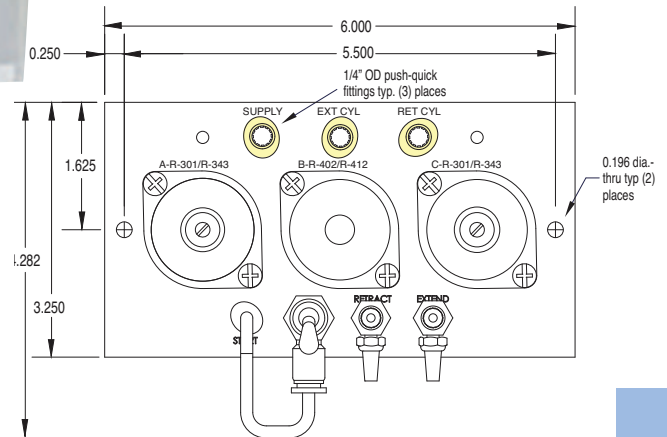

CLIPPARD QUALITY STAINLESS STEEL CYLINDERS

Visit www.clippard.com/cylinders for a complete line of pneumatic cylinders featuring polished I.D 304 stainless steel tubes for low friction.

Clippard—The Preferred Cylinder!



PNEUMATIC MODULES

Back Pressure Sensing for Double-Acting Cylinder



Size: 6.00" x 3.25" x 3.75"

Temperature: 32 to 140°F

Pressure Range: 40 to 150 psig

Use: The VA-031 module is very versatile for controlling a double-acting cylinder without limits. The circuit uses back pressure to send a signal when the cylinder finishes moving. This module is ideal for integrating into a larger circuit with electronic valves or all pneumatic components.

Operation: This circuit enables a double-acting cylinder to give an output-on-output - (LV-) when the cylinder is finished retracting and an output-on-output + (LV+) when cylinder is finished extending. Using these outputs allows you to loop them back to the module's inputs, and create an auto-cycling circuit using back pressure, opposed to a timing signal such as the VA-06 module. You can also use the output to go to a manual button, pneumatic delay valve, electronic valve and PLC, or pneumatic sequencer (such as a R-932 circuit) and allow those options to signal back to the module to begin the next cycle. Call Clippard for assistance to fit the right pneumatic module into your application.

Part No.	Description	
VA-031	Back Pressure Sensing for Double-Acting Cylinder	
Bill of Materials in Assembly		
Qty.	Part No.	Description
2	R-305	3-Way Modular Low Pressure Pilot Valve
1	R-412	4-Way Modular Reset Valve
2	MNV-1KP	Miniature Needle Valve
2	15070	Noise Muffler
1	CM-031-PQ	Circuit Manifold
10'	URT1-0805-GNT	1/4" O.D. Polyurethane Tubing, Green
5'	URT1-0503-CLR	5/32" O.D. Polyurethane Tubing, Clear

All components are also available for individual purchase

The **CM-031** subplate is available with 1/8" NPT and #10-32 threads

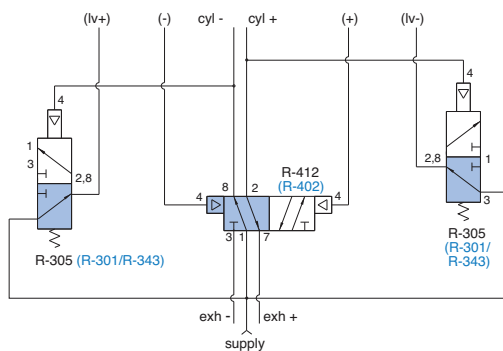
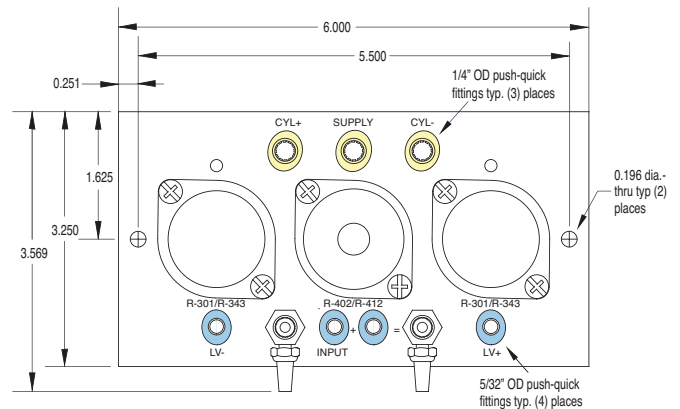

Note: See Pages 249, 255 and 258 for alternative valve(s) (in parenthesis above).

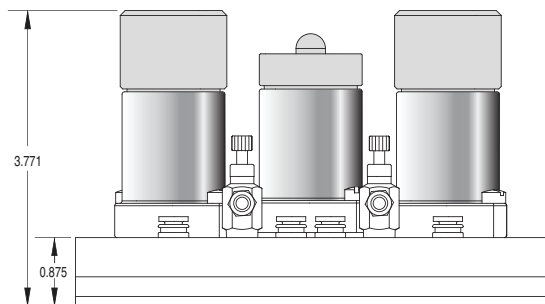

Back Pressure Sensing with a Double-Acting Cylinder Using External Power Valve



Size: 6.0" x 2.75" x 3.50"

Temperature: 32 to 140°F

Pressure Range: 40 to 150 psig

Use: The VA-033 module is very similar to the VA-031 for controlling a double-acting cylinder without limits. The circuit uses back pressure to send a signal when the cylinder finishes moving. This module is designed to be used in conjunction with an external power valve.

Operation: This circuit enables feedback from the external valve outputs to signal back to the module ports CYL+ and - when back pressure is building. Utilizing ports TS and FS allows you to loop them back to the module's inputs, and create an auto-cycling circuit using back pressure, opposed to a timing signal such as the VA-06 module. Or you can use the output to go to a manual button, pneumatic delay valve, electronic valve and PLC, or pneumatic sequencer (such as a R-932 circuit), and allow those options to signal back to the module to begin the next cycle. Call Clippard for assistance to fit our pneumatic modules into your application.

Part No.	Description
<u>VA-033</u>	Back Pressure Sensing with Double-Acting Cylinder Using External Power Valve

Bill of Materials in Assembly

Qty.	Part No.	Description
2	<u>R-305</u>	3-Way Modular Pressure Pilot Valve
1	<u>R-412</u>	4-Way Modular Reset Valve
1	<u>CM-033-PO</u>	Circuit Manifold
8'	<u>URT1-0503-YLT</u>	5/32" O.D. Polyurethane Tubing, Yellow
10'	<u>URT1-0805-GNT</u>	1/4" O.D. Polyurethane Tubing, Green
5'	<u>URT1-0503-CLR</u>	5/32" O.D. Polyurethane Tubing, Clear

All components are also available for individual purchase

The **CM-033** subplate is available with #10-32 threads and no valve assembled

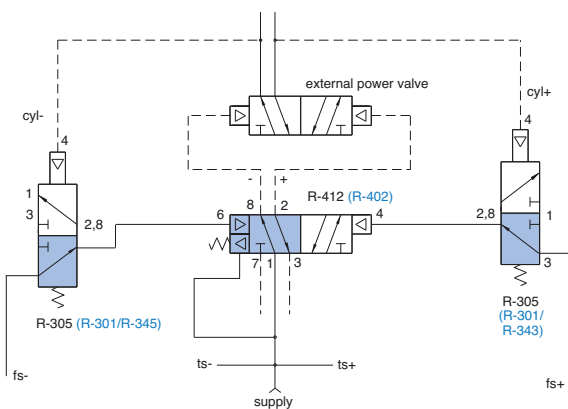
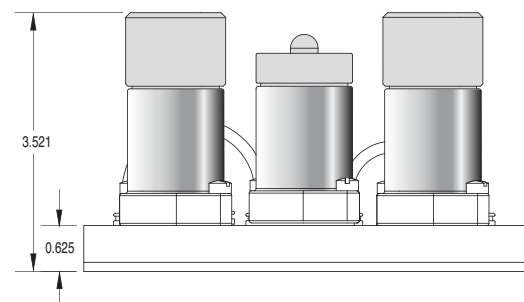
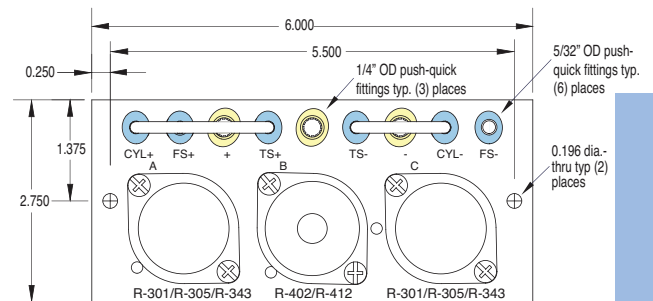

Note: See Pages 248, 255 and 258 for alternative valve(s) (in parenthesis above).



PNEUMATIC I/O MODULES

What is it?

Pneumatic I/O Modules meet unique needs for 100% pneumatically-controlled applications. Today PLC control is commonly used and cost-effective for applications where complex or multiple programs are used and when multiple platforms are required, such as pneumatic, electronic, hydraulic, and/or data acquisition. These pneumatic I/O devices are ideal for Intrinsically Safe environments; simple custom machinery requiring only one program; and PLC type applications that have all pneumatic components for inputs and outputs. This system provides a safe, simple, and cost-efficient answer for pneumatic automation control solutions.



R-932 is a 4-way, 5-ported, double-piloted, two-position valve designed for sequence control I/O modules.

Temperature: 32° to 140°F
Pressure Range: 50 to 150 psig
Input Signals: Requires 40 psig minimum
Output Signals: 9 scfm @ 100 psig (designed to pilot only)
Ports: #10-32 UNF (main supply on VA-024 is 1/8" NPT)
Number of I/O's Available: How many do you want? Clippard recommends a minimum of 2 pneumatic actuators (2 outputs) and up to 8 pneumatic actuators (16 outputs) maximum for this option to be cost-effective compared to PLC controllers and electronic valves. The sequencing circuit is unlimited for applications requiring more outputs.
Operation: The primary function of this control system is to safely give a pneumatic output for every input given in the correct sequence without allowing for a possible jump in sequence or false signal.

Part No.					
Custom or Design-Your-Own from below information					
I/O Modules for Individual Purpose					
Part No.	No. of Steps	"L"	Part No.	No. of Steps	"L"
<u>CM-024</u>	5	9.50"	<u>CM-026</u>	3	6.00"
<u>CM-035</u>	4	7.75"	<u>CM-025</u>	2	4.50"
<u>R-932</u>	Sequence Valves		<u>CM-027</u>	1	2.75"

Add 1 step to the number of steps needed for Reset Signal

* Valves are not included with the CM-XXX Part Numbers. Valves must be ordered separately.

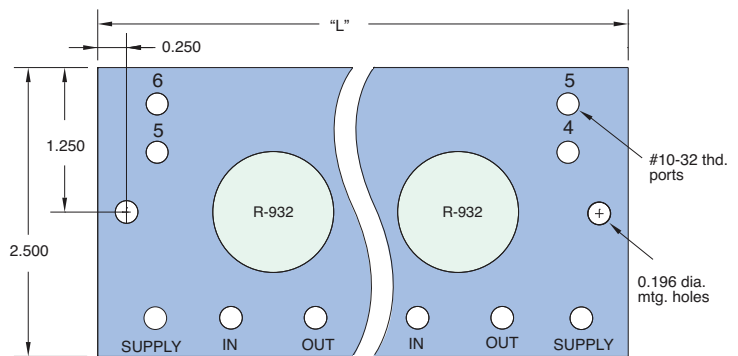

If you are looking for a single Part Number—Assembled, Tested and Shipped directly to you, call us for further information.

I/O Sequence Module Installation

Inputs & Outputs throughout all steps are identical and simple to hook up. For every input or limit valve signal coming in the module will give a corresponding output in the appropriate sequence. Keep in mind that outputs are designed for piloting and not for direct use with pneumatic actuators or devices. Use output pilots to actuate other Clippard Modular valves such as the R-412, Maximatic MMA valves or other manufacturer's components to power your cylinders and devices.

Ports 5 and 6 are used for adding modules and repeating or resetting the sequence. For the first module, plug port 5 and connect port 6 to the last output in sequence in order to reset.

Step one is typically begun with a momentary pneumatic input signal from a toggle valve, push button, Two-Hand, No-Tie-Down control, or solenoid valve. To auto-cycle or repeat the sequence automatically, you will need to keep the signal on until you wish to stop the auto-cycling.

Expanding / Adding Modules allows you to add steps to your sequence. Simply use jumpers to go from port 5 located on the right-hand side of your module, and connect it to port 6 on the left-hand side of the added module. Repeat this for connecting 4 to 5, and don't forget to connect a supply line as well.

Reset and Continuous Cycles is used when the sequence of operation repeats, such as in automated production equipment. This step is required regardless if you are auto-cycling or manually starting each sequence. Port 5 should be plugged, port 4 should be connected to the supply port, and the last step output should go to port 6 on the first step's module. Plug any unused supply ports and you are ready to go.

Added Functionality is commonly desired and easily achieved with these modules. Since there are countless possibilities for pneumatic control, we ask that you contact Clippard directly for pneumatic logic assistance or for a complete design and assembly.

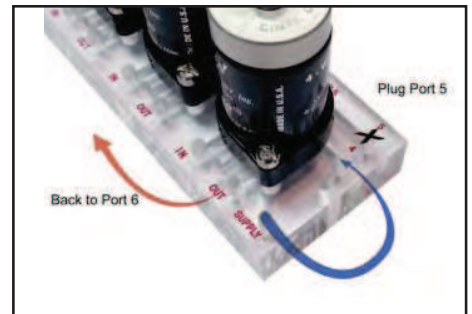
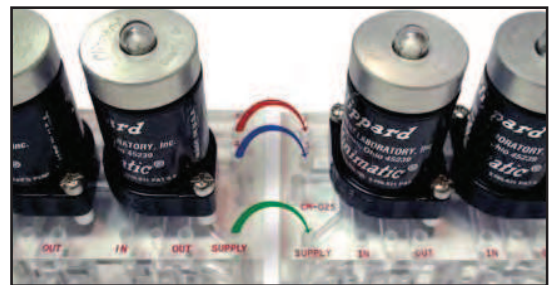
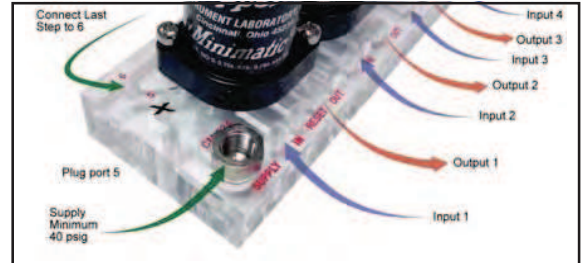

Complete Pneumatic Control Modules



The complete solution:

Not everyone can design pneumatic control circuits like Clippard. Long the leader in pneumatic logic, we are prepared to meet your needs.

If knowledge or time is hard to come by on a pneumatic project, call us for circuit assistance, design, assembly, and testing. Within Clippard's Value-Added department, we have years of experience designing and assembling pneumatic systems for thousands of applications in a variety of markets.

What we need!

Give us your requirements for input and outputs, required response times, flows, and space restrictions. We will propose a fully-assembled control unit that is designed and built just for your needs.



MODULAR VALVE SYSTEM

MANIFOLD BODY

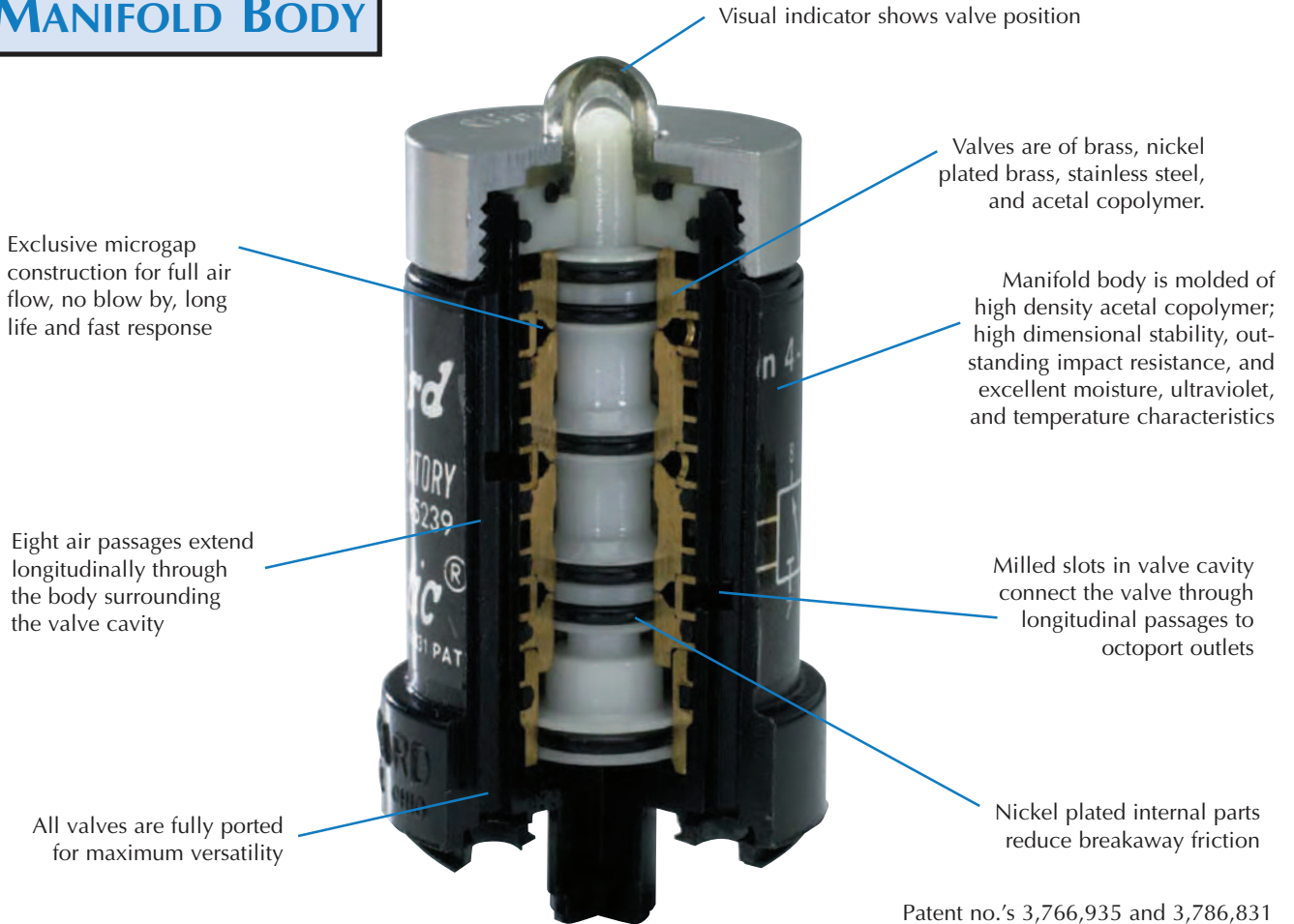

Patent no.'s 3,766,935 and 3,786,831

Octoport Port Coding

The coding method shown here is used on the individual product catalog sheets. You will find a port usage diagram furnished for each variation of each model shown. Letters are used to identify port usage:

- S - Supply or Signal
- O - Output
- E - Exhaust
- P - Pilot Input

Where more than one supply, output, exhaust, etc. are involved in one module, subscript numerals are provided: S₁, S₂, etc. Where an auxiliary output is provided it may be identified by the letter O in parentheses: (O).

NOTE: Many of the Octoport valves have multiple ported supplies, outputs, or exhausts, etc. The port usage symbols will usually show one or the other of these ports with an "X" (must be plugged) in it. Both or either of the multiple ports may be used. Unused multiple ports must be plugged. The ANSI symbol will always show which valves have multiple ports.

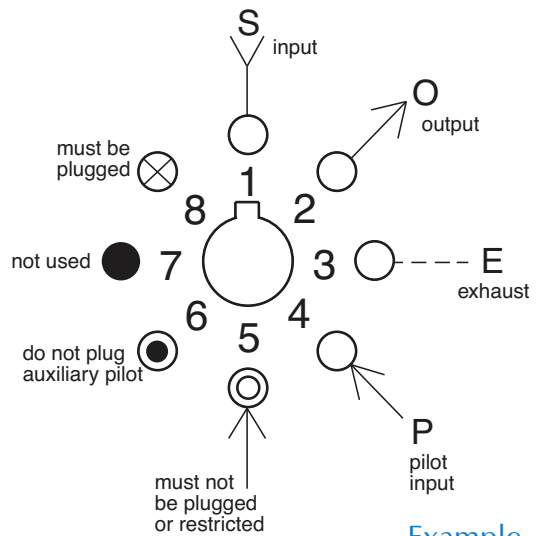

Example

The 3 Base Modular Valves

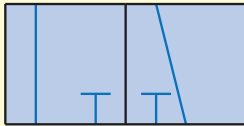

- Can be used as a:
- 2-way normally closed valve
 - 2-way normally open valve
 - 3-way normally closed valve
 - 3-way normally open valve
 - 3-way diverter valve
 - 3-way selector valve



- Can be used as a:
- 4-way fully ported valve
 - Dual 2-way valves (one N.O. & one N.C.)
 - Dual 3-way valves with common exhaust (one N.O. & one N.C.)

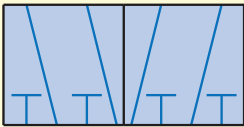

- Can be used as a:
- 6-way fully ported valve
 - Dual 2-way normally closed valve
 - Dual 2-way normally open valve
 - Dual 3-way normally closed valve
 - Dual 3-way normally open valve
 - Dual selector valve

* R-436 and R-421 are exceptions to the Basic 3

Versatility is the key when it comes to Clippard's Minimatic® Modular Valves. Available in an unlimited variety of directional, flow, pressure and special control valves - each in a valve body designed to mount and link together with a simple piping system. The piping system eases assembly and plumbing, resulting in reduced labor costs, errors in installation, and the potential for plumbing leakage. In addition, multiple valve elements can be contained in a single body; providing incredible flexibility and variety to accomplish a myriad of control challenges. The Minimatic modular valves are the supreme "Plug and Play" devices for pneumatic applications.

Actuation Methods

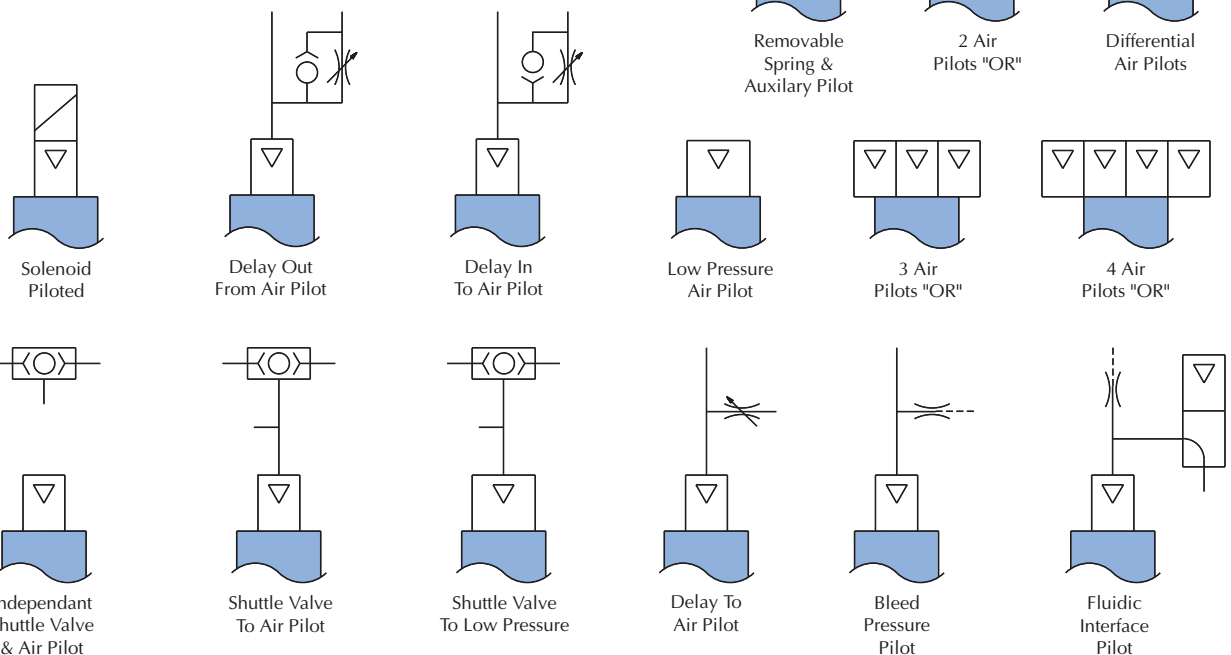
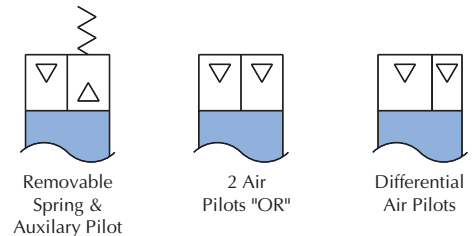
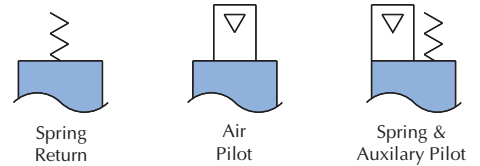



MODULAR VALVE SYSTEM

SIMPLIFIED ASSEMBLY

Screws and lockwashers (replacement part R-105) plated steel, binder head, #10-32 thread.



Molded gasket (replacement Part No. R-104) furnished with each module.

Custom plastic manifold subplates of clear plastic have most interconnections inside; speed assembly, assure integrity of circuit. Valves plug in easily.

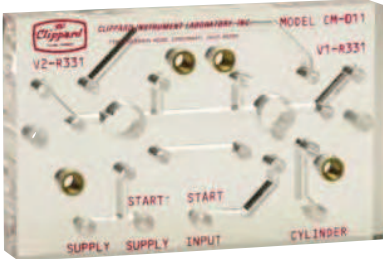

Standard mounting strips attach to interlocked subplates with #10-32 screws. Resulting circuit plate is rigid and strong. Modules plug in to circuit plate and are held by two fully captivated screws. Molded gasket provides seal between each module and subplate.

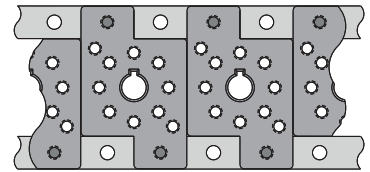
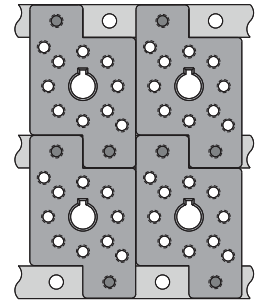
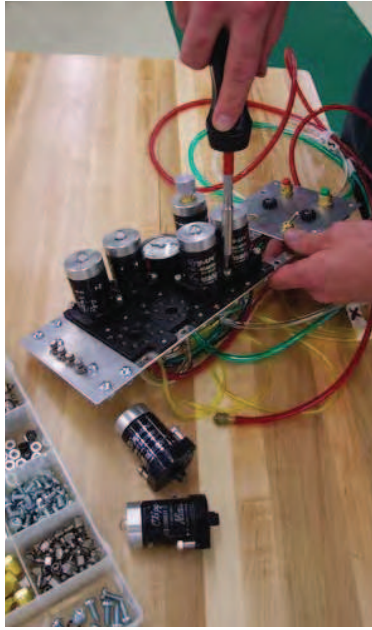

Manifold Module Dimensions

Module manifold body is injection molded high density acetal copolymer for high dimensional stability, outstanding impact resistance, and excellent moisture, ultraviolet, and temperature characteristics.

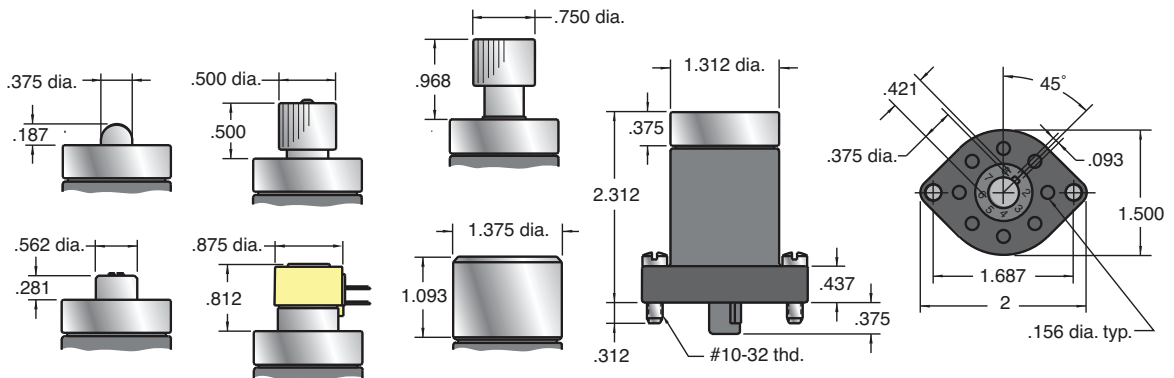

Octoport Stamp

Part number R-108

Complete pneumatic circuit drawings in minimum time with this small, self inked octoport stamp.



System Requirements

The Clippard Minimatic® modular components system is designed to operate on standard shop air. The air supply should be reasonably clean and dry for optimum performance. The system operating range is 0 to 150 psig. Recommended filtration is 40 micron. Many units have pilot pressure requirements of 20 to 40 psig, therefore, system pressure should be sufficient to assure 40 psig as the absolute minimum pilot pressure at all times. A normal system operating pressure from 60 to 100 psig should adequately provide this. The system operates in a temperature range of 32 to 230°F.

NOTE: Constant operation at temperature range extremes may affect system performance.



Mounting Subplates provide mounting for up to three modular valves, and provide various port options. Very compact size, lightweight, easy-to-mount, and valves are easily replaced.

Part No.	No. of Valves	Ports	Length	Width	Height	Mounting
<u>CM-04</u>	1	#10-32	3.00"	3.00"	0.625"	(2) 0.196" dia.
<u>CM-02</u>	1	1/8" NPT	3.50"	3.00"	0.625"	(2) 0.196" dia.
<u>CM-036</u>	2	1/8" NPT	7.00"	3.00"	0.625"	(4) 0.196" dia.
<u>CM-037</u>	3	1/8" NPT	10.75"	3.00"	0.625"	(4) 0.196" dia.

Subplate Dimensions

R-101/R-101-M5 subplate mounts to mounting strips with #10-32 screws and lockwashers provided. Ports on module base are numbered in the same pattern as on the subplate, making piping easy to identify. Module stem is keyed to fit center hole in subplate; assures fast insertion and proper positioning.

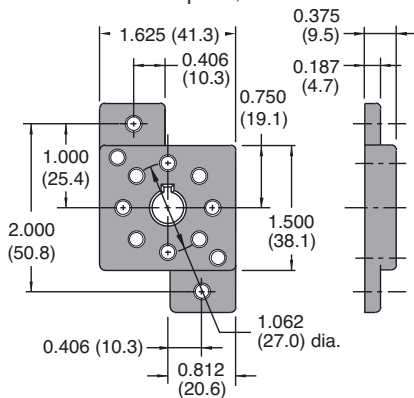

R-101 & R-101-M5 (metric)

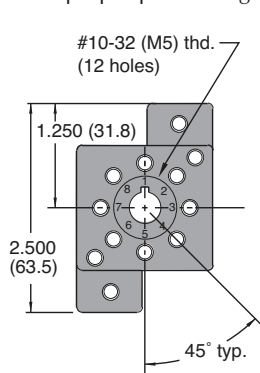

R-111 & R-111-M5 (metric)

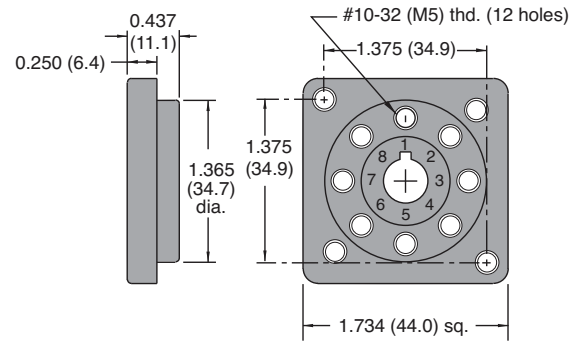

R-111/R-111-M5 subplate mounts in 1 3/8" (34.9) hole in electrical box, control panel. Mounting screws and gasket provided seal subplate to mounting plate.

Mounting Strips & Stand-Off Dimensions

R-107-20

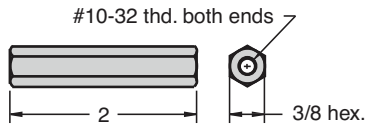

For providing space beneath assembled group of modules, use R-106 (order R-107-20, packet of four with hardware). Provides 2" clearance from enclosure wall for piping with Clippard fittings and tubing. Keeps piping and installation neat.

When subplates are mounted to mounting strips, the components build into a strong, rigid assembly. Because of extra tolerance in the holes, note that strips may be adjusted before screws are fully tightened. This permits accurate alignment of subplates. The identifying number following the second dash in the part number indicates the number of modules the strip will accommodate while still proving a short extension with one hole at both ends for using in mounting the assembly to stand-offs or other structures. The strip will accommodate 1 additional module if no extensions for mounting are needed. (Every two holes will accept a subplate.)

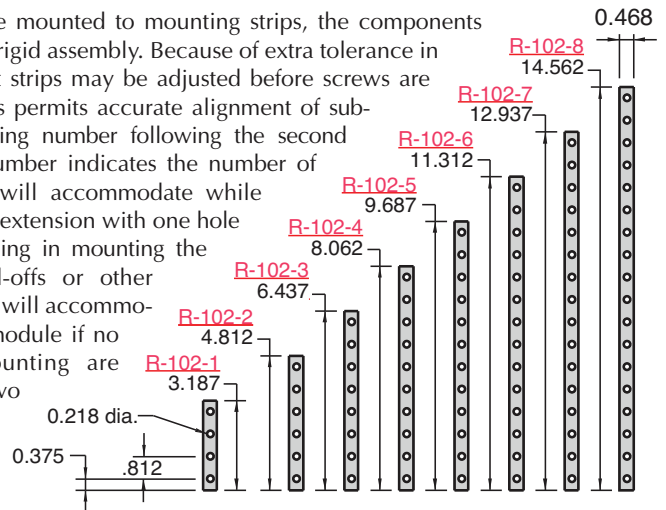



BUILDING A PNEUMATIC CIRCUIT

STEP ONE

Pneumatic Circuit

The first step in building a modular circuit is designing the pneumatic circuit using ANSI symbols.

We have chosen the Two-Hand, No-Tie-Down Circuit ([page 232](#)) for this demonstration.

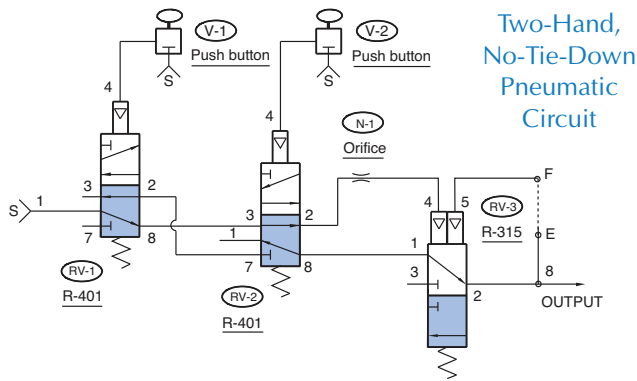

STEP TWO

Specifications for the [R-315](#) modular valve

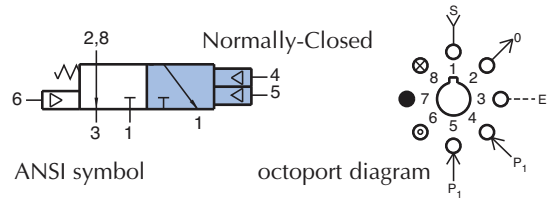

Octoport Diagrams

The next step is selecting the octoport diagram for each modular valve. Each Clippard modular valve (R-series) has its own unique octoport diagram which is shown to the right of the ANSI symbol.

See [page 242](#) for clues for deciphering the Octoport port coding.

STEP THREE

Components for Modular Circuit

Next, you need to gather the required components. Typically, the modular portion of a circuit consists of modular valves, subplates, mounting strips, 1/16" and 1/8" fittings, 1/16" and 1/8" hose, and the main air supply connect fitting.

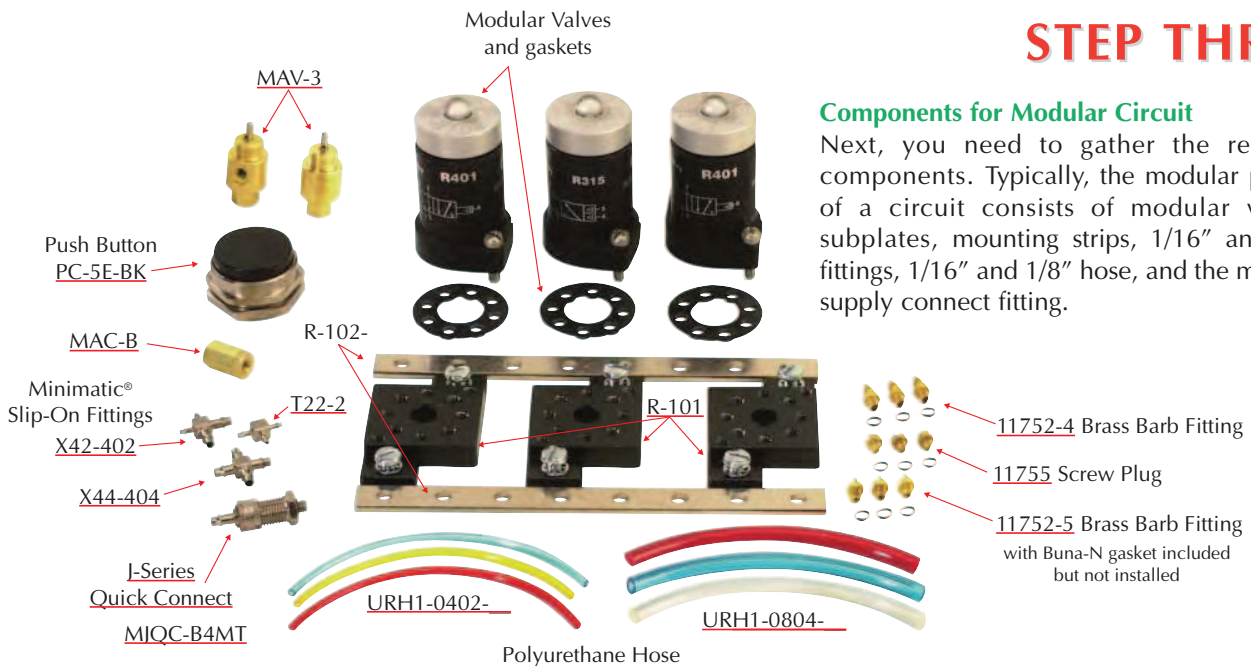

STEP FOUR

Mounting Strip and Subplate Assembly

The next step is assembling the mounting strips (R-102) and subplates (R-101/R-101-M5).

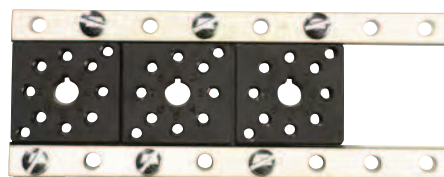

Possible configurations for subplates

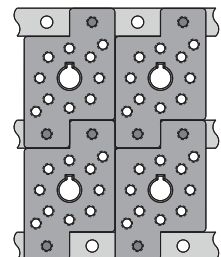

Subplate and Fitting Installation

The next step is to install the fittings into the R-101/R-101-M5 subplates using the octoport, octoport port coding, and pneumatic circuit diagrams. Generally, 1/16" hose is used for pilot ports and their adjoining lines and 1/8" hose are for supply lines and cylinders.

Looking at the Two-Hand, No-Tie-Down circuit:

1. Valve RV-1 has fitting [11752-5](#) (#10-32 to 1/16" I.D. hose fitting) installed in ports 4 and 8
2. Fitting [11752-4](#) (#10-32 thd. to 1/8" I.D. hose fitting) installed in ports 1 and 2 because port 1 is the main air supply for the circuit and port 2 is the outlet.
3. On valves V-1 and V-2, fitting [11752-5](#) was installed in both the inlet and outlet of each valve because both valves are used for pilot actuation of valves RV-1 and RV-2.

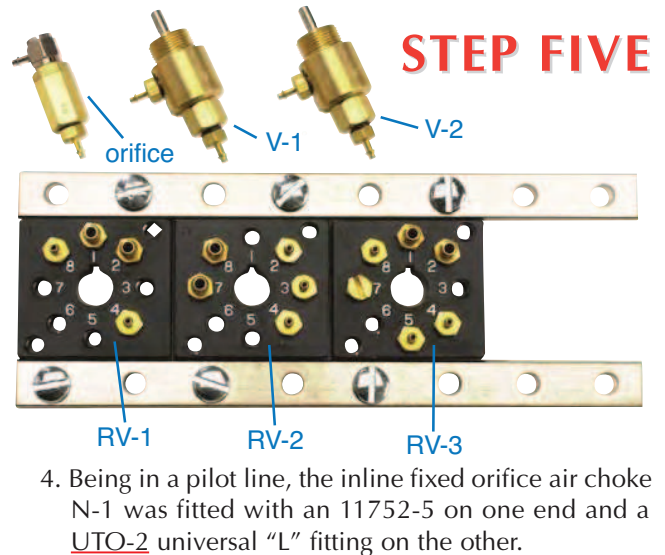

4. Being in a pilot line, the inline fixed orifice air choke N-1 was fitted with an [11752-5](#) on one end and a [UTO-2](#) universal "L" fitting on the other.

STEP SIX

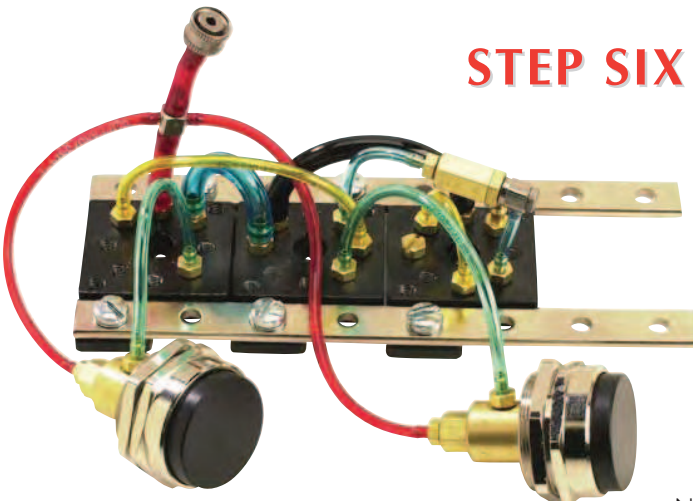

Connecting Hose

With the fittings installed, the circuit is ready for hose. The color coding we use at Clippard is quite simple. Red hose is used for all supply lines. For all other hose as many different colors as possible are used in order to facilitate circuit trouble shooting.

1. Supply lines - Red hose
2. The 1/16" I.D. fittings require URH1-0402 hose
3. The 1/8" I.D. fittings require URH1-0804 hose
4. The main supply line was fitted with a [MJQC-CB4](#) which can be attached to any of the MJQC valve bodies.

Note: The MJQC series is not compatible with the MQC series.

STEP SEVEN

Modular Valve Hook-Up

The final assembly step is installing the modular valves and mounting gasket to the subplates.

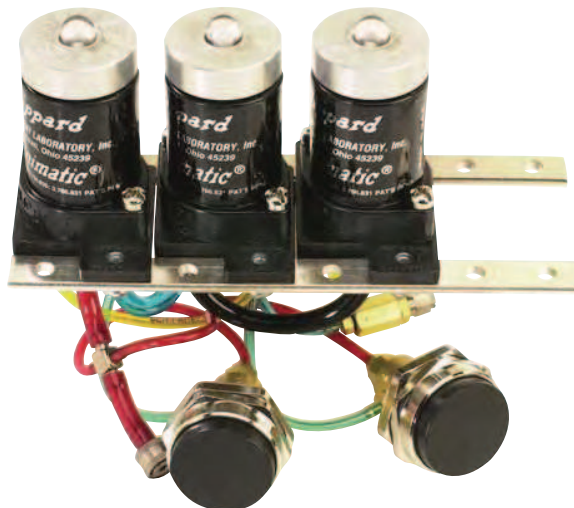

Hose and barb sizes were picked with this particular application in mind. Both may vary to meet your needs. Feel free to contact our facility for technical support.



MODULAR 3-WAY VALVE

R-301

3-Way Valve

Features:

- Indicator shows valve in shaded position
- Multiple porting speeds piping
- Micro gap construction - snap action and no blow by
- Balanced design allows speed control at exhausts

Performance:

Flow: 9 scfm @ 100 psig; 255 l/min @ 6.9 bars
Pilot Pressure Minimum: 40 psig; 2.8 bars
Temperature: 32 to 180°F
Working Pressure: Vacuum to 150 psig; 10.3 bars



Description:

R-301 is a 3-way, spring return, fully ported, piloted valve. It can be used Normally-Open, Normally-Closed, as a diverter or as a selector. It can also be used as a 2-way valve by plugging the exhaust ports.

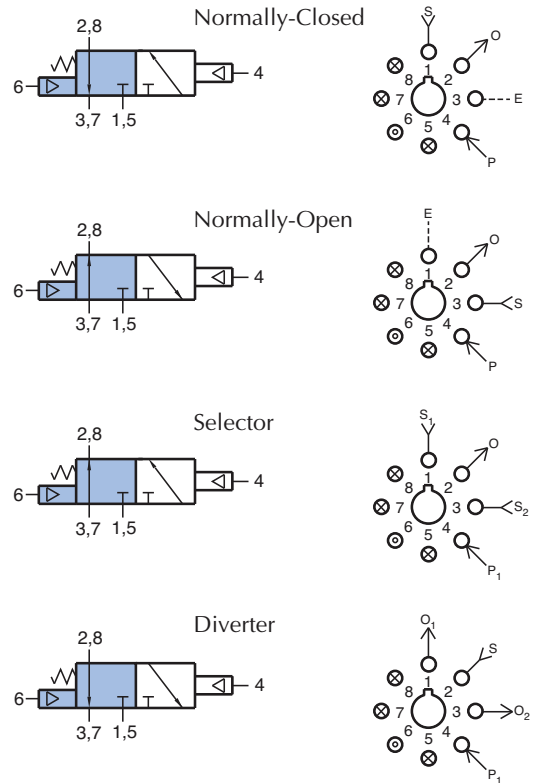

R-302

3-Way Valve

Features:

- Indicator shows valve in shaded position
- Multiple porting speeds piping
- Micro gap construction - snap action and no blow by
- Balanced design allows speed control at exhausts

Performance:

Flow: 9 scfm @ 100 psig; 255 l/min @ 6.9 bars
Pilot Pressure Minimum: 20 psig; 1.4 bars
Temperature: 32 to 180°F
Working Pressure: 0 to 150 psig; 0 to 10.3 bars



Description:

R-302 is a 2-position, 3-way, double-piloted, fully ported valve. It can be used Normally-Open, Normally-Closed, as a 2-position diverter, as a 2-position selector, or as a 2-way valve by plugging the exhaust ports.

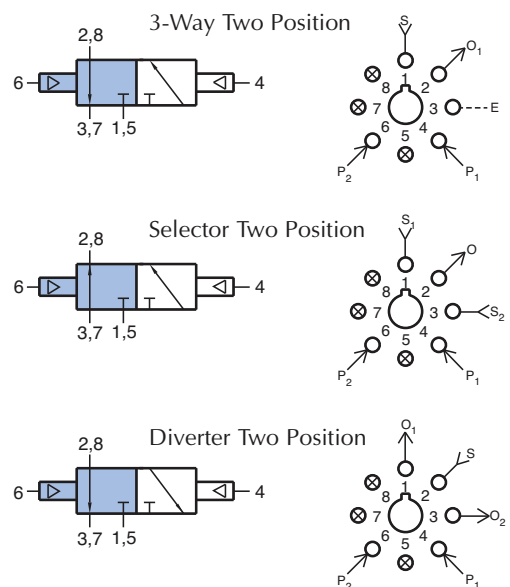

R-305

3-Way Low Pressure Pilot Valve



Features:

- Pilot actuates valve with low pressure signal
- Multiple porting speeds piping
- Micro gap construction - snap action and no blow by
- Balanced design allows speed control at exhausts

Performance:

Flow: 9 scfm @ 100 psig; 255 l/min @ 6.9 bars
Pilot Pressure Minimum: 15 psig; 1.0 bars
Temperature: 32 to 180°F
Working Pressure: 0 to 150 psig; 0 to 10.3 bars

Description:

R-305 is a 3-way, spring-return, fully ported valve with a low pressure pilot. Pilot pressure signals as low as 15 psig will actuate the valve. The valve can be used Normally-Open, Normally-Closed, as a selector or as a diverter. The R-305 may be used in place of an R-301 valve where a lower pilot actuation pressure is desired. It can also be used as a 2-way valve by plugging the exhaust ports.

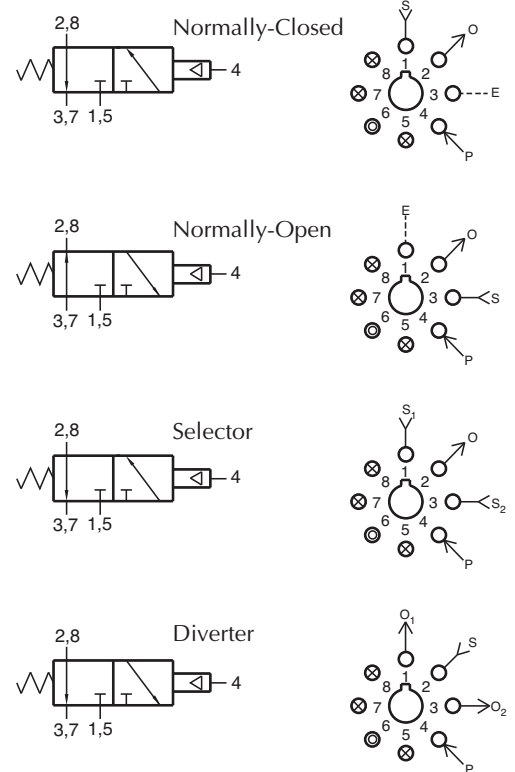

R-310

3-Way Reset Valve



Features:

- Indicator shows valve in shaded position
- Multiple porting speeds piping
- Micro gap construction - snap action and no blow by
- Balanced design allows speed control at exhausts
- Unique piloted spring reset

Performance:

Flow: 9 scfm @ 100 psig; 255 l/min @ 6.9 bars
Pilot Pressure Minimum (against spring): 40 psig; 2.8 bars
Pilot Pressure Minimum (spring retracted): 20 psig; 1.4 bars
Temperature: 32 to 180°F
Working Pressure: 0 to 150 psig; 0 to 10.3 bars

Description:

R-310 is a 3-way, fully ported valve with a special air retracted spring return that will return the valve to a definite position when there is no signal at ports 5 and 4. This "reset" feature may be used in circuits in the event of loss of air pressure or to change the operating characteristics of the valve in the circuit in response to an independent input at port 5. When port 5 is not piloted, the R-310 acts as an R-301 3-way spring return, fully ported valve. When port 5 is actuated, the R-310 acts as an R-302 3-way, two position valve. With no signal at port 5, a signal at port 6 acts as an auxiliary pilot type valve and will override a signal at port 4.

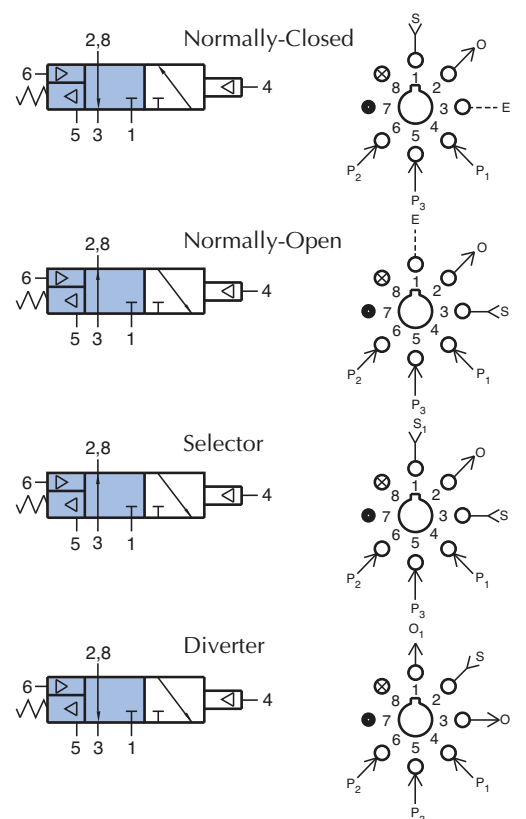



MODULAR 3-WAY VALVES

R-311



Description:

R-311 is a 3-way, spring return, fully ported valve with four pilots. Any one of the four pilots will actuate the valve. Actuating more than one pilot has no additional effect. Pilot signals must be absent at all four pilots to release the valve. The valve can be used Normally-Open, Normally-Closed, as a selector or as a diverter, all with four pilot inputs. It can also be used as a 2-way valve by plugging the exhaust ports. The R-311 may be used to replace an R-301 or R-321 valve in a circuit when additional pilot inputs are required. The R-311 also features an auxiliary pilot on the spring side of the valve. The auxiliary pilot will overcome any one or all of the four input pilots.

3-Way Multiple Pilot Valve

Features:

- Indicator shows valve in shaded position
- Multiple pilots reduces number of valves - reduces piping and space required
- Micro gap construction - snap action and no blow by
- Balanced design allows speed control at exhaust

Performance:

Flow: 9 scfm @ 100 psig; 255 l/min @ 6.9 bars
Pilot Pressure Minimum: 40 psig; 2.8 bars
Temperature: 32 to 180°F
Working Pressure: 0 to 150 psig; 0 to 10.3 bars

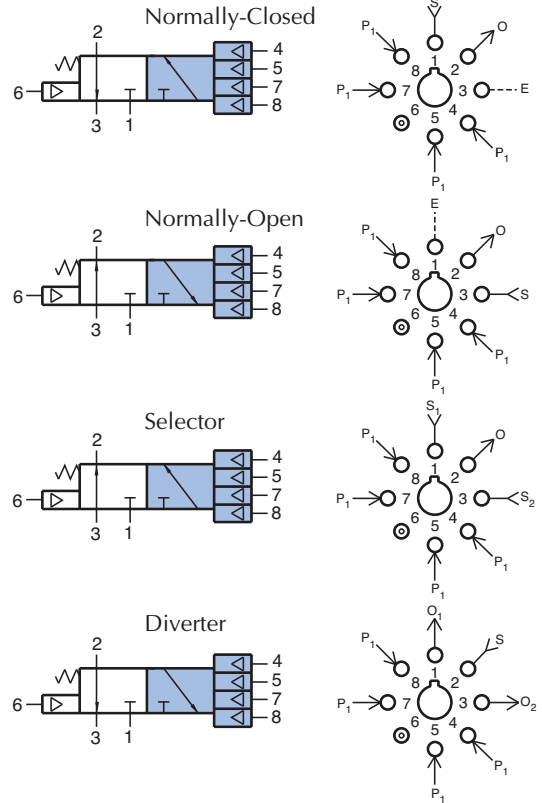

R-312



Description:

R-312 is a 3-way, two position, fully ported valve with four pilots on one position. Any one of the four pilots on one position will actuate the valve. Actuating more than one pilot has no additional effect. Pilot signals must be absent at all four pilots before the opposite pilot can shift the valve. The valve can be used Normally-Open, Normally-Closed, as a selector, or as a diverter, all with four pilot inputs. It can also be used as a 2-way valve by plugging the exhaust ports. The R-312 may be used to replace an R-302 or R-322 valve in a circuit when additional pilot inputs are required.

3-Way Multiple Pilot Valve

Features:

- Indicator shows valve in shaded position
- Multiple pilots reduces number of valves - reduces piping and space required
- Micro gap construction - snap action and no blow by
- Balanced design allows speed control at exhaust

Performance:

Flow: 9 scfm @ 100 psig; 255 l/min @ 6.9 bars
Pilot Pressure Minimum: 20 psig; 1.4 bars
Temperature: 32 to 180°F
Working Pressure: 0 to 150 psig; 0 to 10.3 bars

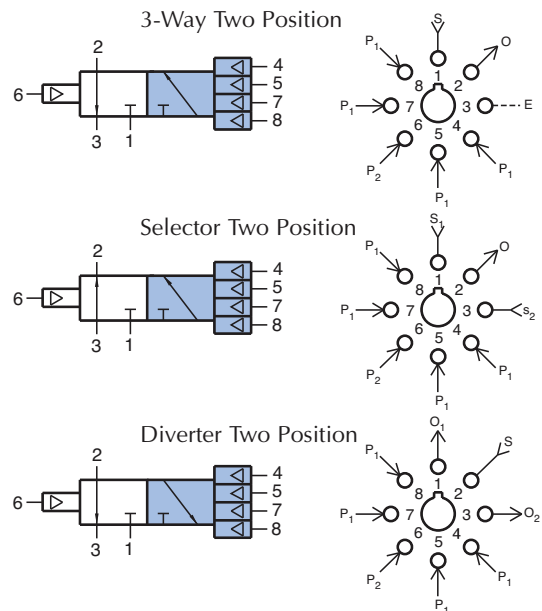

R-314



3-Way Multiple Pilot Valve

Features:

- Multiple pilots reduces number of valves - reduces piping and space required
- Micro gap construction - snap action and no blow by
- Balanced design allows speed control at exhausts

Performance:

Flow: 9 scfm @ 100 psig; 255 l/min @ 6.9 bars
Pilot Pressure Minimum: 20 psig; 1.4 bars
Temperature: 32 to 180°F
Working Pressure: 0 to 150 psig; 0 to 10.3 bars

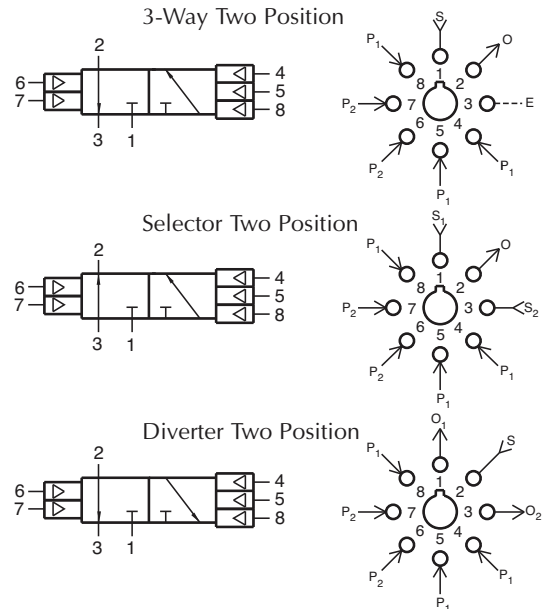

Description:

R-314 is a 3-way, air piloted, two position valve. It has three pilots on one side and two pilots on the other side. (see symbol) Actuating more than one pilot on the same side has no additional effect. Pilot signals must be absent from all pilots (on the same side) before an opposite pilot will shift the valve. The valve can be used Normally-Open, Normally-Closed; as a selector, or as a diverter. It may be used as a 2-way valve by plugging the exhaust ports.

R-315



3-Way Multiple Pilot Valve

Features:

- Indicator shows valve in shaded position
- Multiple pilots reduces number of valves - reduces piping and space required
- Micro gap construction - snap action and no blow by
- Balanced design allows speed control at exhaust

Performance:

Flow: 9 scfm @ 100 psig; 255 l/min @ 6.9 bars
Pilot Pressure Minimum: 40 psig; 2.8 bars
Temperature: 32 to 180°F
Working Pressure: 0 to 150 psig; 0 to 10.3 bars

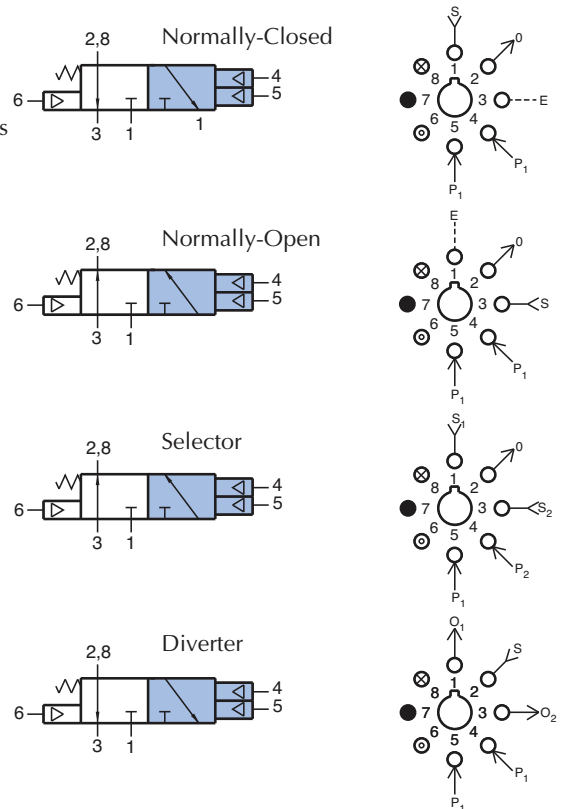

Description:

R-315 is a 3-way, spring return, fully ported valve with two independent pilots that make it ideal for "latch" circuits. Either of the two pilots will actuate the valve. Actuating more than one pilot has no additional effect. Pilot signals must be absent at both pilots to release the valve. The valve can be used Normally-Open, Normally-Closed, as a selector or as a diverter. It can also be used as a 2-way valve by plugging the exhaust ports. The R-315 may be used to replace an R-301 valve in a circuit when additional pilot inputs are required. The R-315 also features an auxiliary pilot on the spring side of the valve. The auxiliary pilot will overcome any one or all of the four input pilots.



MODULAR 3-WAY COMBINATION VALVES

R-321



3-Way Combination Valve

Features:

- Indicator shows valve in shaded position
- Multiple porting speeds piping
- Micro gap construction - snap action and no blow by
- Balanced design allows speed control at exhausts

Performance:

Flow: 9 scfm @ 100 psig; 255 l/min @ 6.9 bars
Pilot Pressure Minimum: 40 psig; 2.8 bars
Temperature: 32 to 180°F
Working Pressure: 0 to 150 psig; 0 to 10.3 bars

Description:

R-321 is a 3-way, spring return, fully ported valve with an interconnected shuttle valve in one pilot line to provide two inputs to the pilot. It can be used Normally-Open, Normally-Closed, as a diverter, or as a selector. Auxiliary outlet is provided through port 7, which should be plugged if not used.

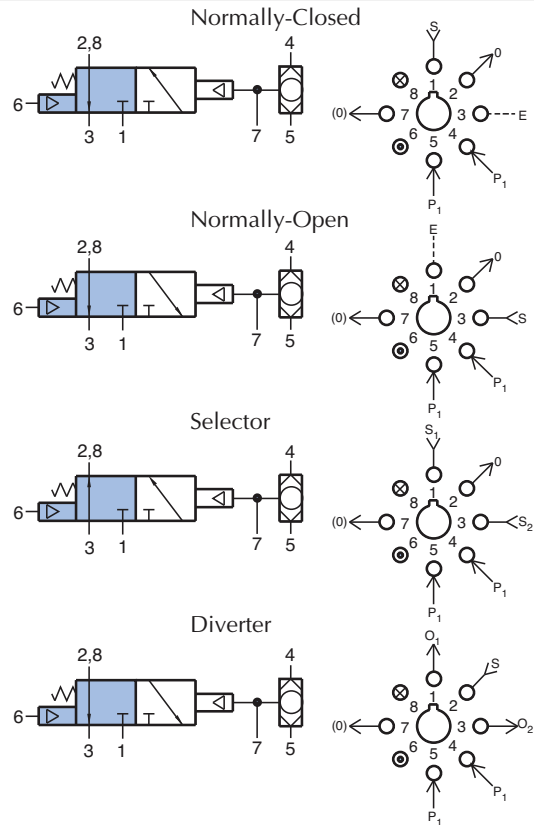

R-322



3-Way Combination Valve

Features:

- Indicator shows valve in shaded position
- Multiple porting speeds piping
- Micro gap construction - snap action and no blow by
- Balanced design allows speed control at exhausts

Performance:

Flow: 9 scfm @ 100 psig; 255 l/min @ 6.9 bars
Pilot Pressure Minimum: 20 psig; 1.4 bars
Temperature: 32 to 180°F
Working Pressure: 0 to 150 psig; 0 to 10.3 bars

Description:

R-322 is a 3-way valve, 2-position, fully ported, with an interconnected shuttle valve in one pilot line to provide two inputs to the pilot. It can be Normally-Open, Normally-Closed, as a 2-position selector, or as a 2-position diverter. Auxiliary outlet is provided through port 7, which should be plugged if not used.

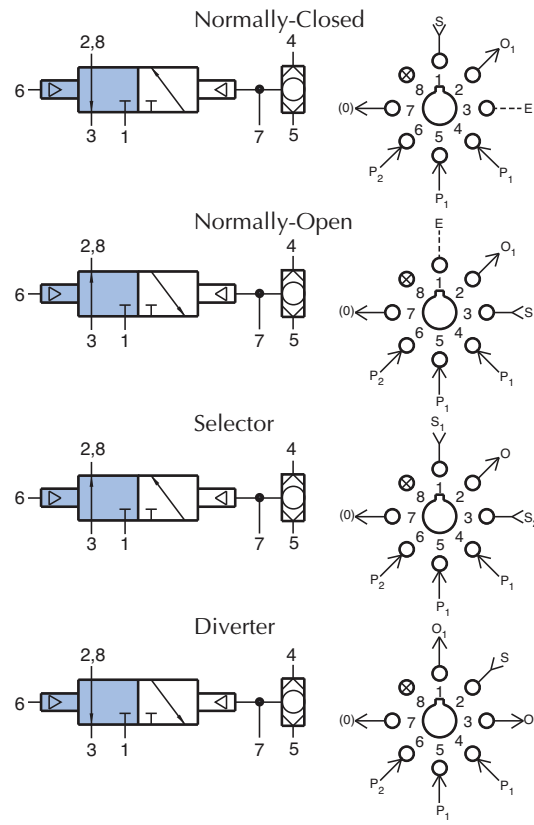

MODULAR 3-WAY COMBINATION VALVES



R-323



3-Way Combination Valve

Features:

- Indicator shows valve in shaded position
- Multiple valves save space
- Micro gap construction - snap action and no blow by
- Balanced design allows speed control at exhausts

Performance:

Flow: 9 scfm @ 100 psig; 255 l/min @ 6.9 bars
Pilot Pressure Minimum: 40 psig; 2.8 bars
Temperature: 32 to 180°F
Working Pressure: 0 to 150 psig; 0 to 10.3 bars

Description:

R-323 is a 3-way, spring return, fully ported valve with an independent shuttle valve in the same body. Both valves may be used independently in a circuit. The 3-way can be used Normally-Open, Normally-Closed; as a diverter, or as a selector. The R-323 also features an auxiliary pilot on the spring side of the valve.

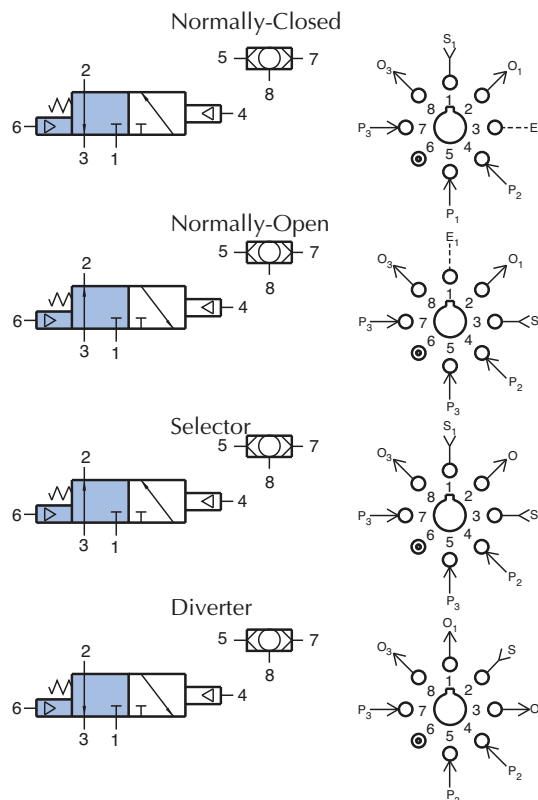

R-324



3-Way Combination Valve

Features:

- Indicator shows valve in shaded position
- Multiple valves save space
- Micro gap construction - snap action and no blow by
- Balanced design allows speed control at exhausts

Performance:

Flow: 9 scfm @ 100 psig; 255 l/min @ 6.9 bars
Pilot Pressure Minimum: 20 psig; 1.4 bars
Temperature: 32 to 180°F
Working Pressure: 0 to 150 psig; 0 to 10.3 bars

Description:

R-324 is a 3-way, two position, fully ported valve with an independent shuttle valve in the same body. Both valves may be used independently in a circuit. The 3-way can be used Normally-Open, Normally-Closed; as a diverter, or as a selector.

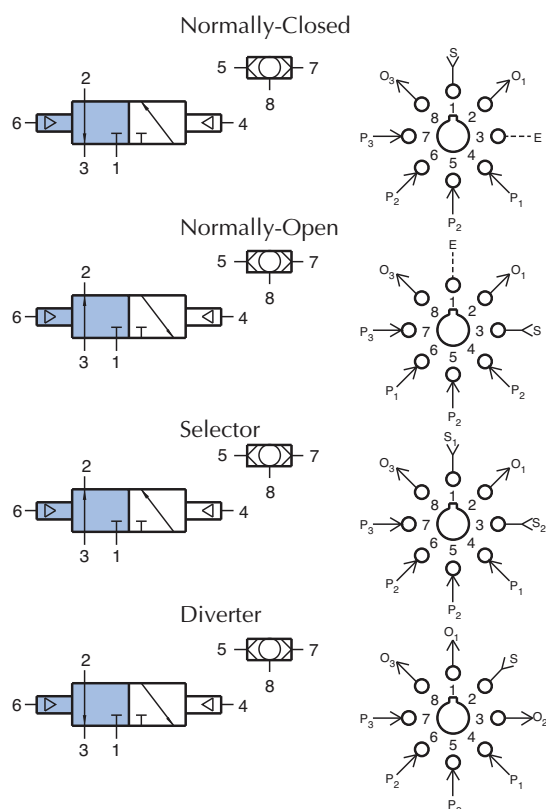



MODULAR 3-WAY COMBINATION VALVES

R-325



3-Way Low Pressure Combination Valve

Features:

- Pilot actuates valve with low pressure signal
- Multiple porting speeds piping
- Micro gap construction - snap action and no blow by
- Balanced design allows speed control at exhausts

Performance:

Flow: 9 scfm @ 100 psig; 255 l/min @ 6.9 bars
Pilot Pressure Minimum: 15 psig; 1.0 bar
Temperature: 32 to 180°F
Working Pressure: 0 to 150 psig; 0 to 10.3 bars

Description:

R-325 is a 3-way, spring return, fully ported valve with a low pressure pilot and an interconnected shuttle valve to provide two inputs to the low pressure pilot. It can be used Normally-Closed, Normally-Open, as a 2-position diverter, or as a 2-position selector. The R-325 may be used in place of an R-321 valve where a lower pilot pressure is desired. Auxiliary outlet is provided through port 7, which should be plugged if not used.

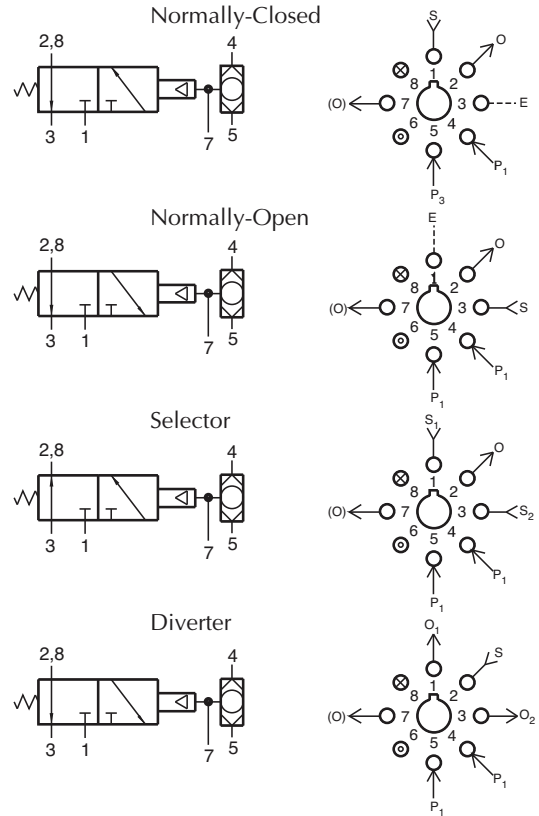

R-331 R-333



3-Way Delay Valve

Features:

- Multiple porting speeds piping
- Micro gap construction - snap action and no blow by
- Screwdriver slot needle adjustment deters tampering (R-333)
- Knurled knob for fast accurate adjustments - no tools needed (R-331)
- 0-5 seconds range

Performance:

Flow: 9 scfm @ 100 psig; 255 l/min @ 6.9 bars
Pilot Pressure Minimum: 40 psig; 2.8 bars
Temperature: 32 to 180°F
Working Pressure: 0 to 150 psig; 0 to 10.3 bars

Description:

R-331 and R-333 are dual element combinations consisting of a fully ported, spring return, 3-way valve, and an adjustable flow control to provide a delay "IN" function. Input signal at port 4 will be delayed through adjustable flow control and will delay the actuation of the valve. The 3-way valve is fully ported and can be used Normally-Open, Normally-Closed, or as a selector or diverter. Port 7 is an auxiliary for adding volume for longer time delays. If not used, port 7 should be plugged.

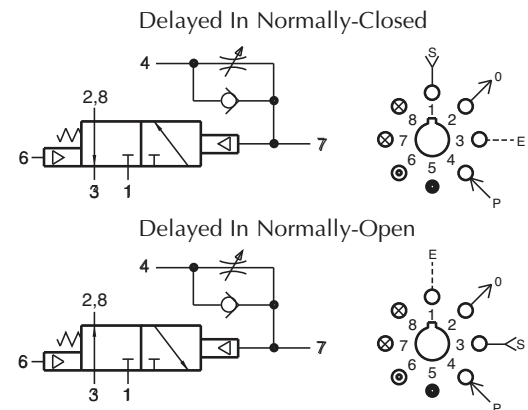

MODULAR 3-WAY DELAY VALVES



R-332 R-334



3-Way Delay Valve

Features:

- Multiple porting speeds piping
- Micro gap construction - snap action and no blow by
- Screwdriver slot needle adjustment deters tampering (R-334)
- Knurled knob for fast accurate adjustments - no tools needed (R-332)
- 0-3 seconds range

Performance:

Flow: 9 scfm @ 100 psig; 255 l/min @ 6.9 bars
Pilot Pressure Minimum: 20 psig; 1.4 bars
Temperature: 32 to 180°F
Working Pressure: 0 to 150 psig; 0 to 10.3 bars

Description:

R-332 and R-334 are dual element combinations consisting of a 2-position, 3-way valve, fully ported, and an adjustable flow control to provide a delay "IN" function. Input signal at port 4 will be delayed through adjustable flow control and will delay the actuation of the valve. The 3-way valve can be used Normally-Open, Normally-Closed, as a 2-position selector or 2-position diverter. Port 7 is an auxiliary for adding volume for longer time delays. If not used, port 7 should be plugged.

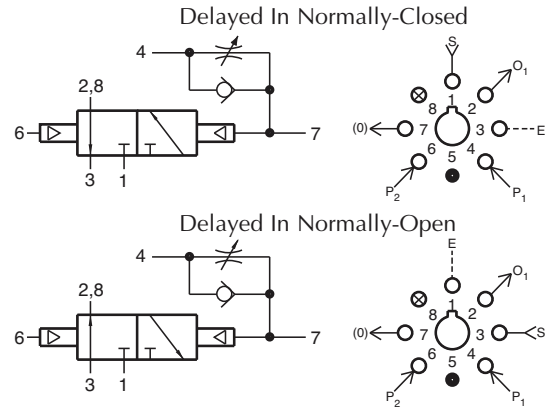

R-341 R-343



3-Way Delay Valve

Features:

- Multiple porting speeds piping
- Micro gap construction - snap action and no blow by
- Screwdriver slot needle adjustment deters tampering (R-343)
- Knurled knob for fast accurate adjustments - no tools needed (R-341)
- 0-7 seconds range

Performance:

Flow: 9 scfm @ 100 psig; 255 l/min @ 6.9 bars
Pilot Pressure Minimum: 40 psig; 2.8 bars
Temperature: 32 to 180°F
Working Pressure: 0 to 150 psig; 0 to 10.3 bars

Description:

R-341 and R-343 are dual element combinations consisting of a fully ported spring return, 3-way valve and an adjustable flow control to provide a delay "out" function. Input signal at port 4 actuates the valve immediately; and upon loss of pressure signal at port 4, the valve remains in position until pilot pressure decays through the flow control. The valve can be used as Normally-Open or Normally-Closed, and as a diverter or selector. Port 7 is an auxiliary for adding volume for longer time delays.

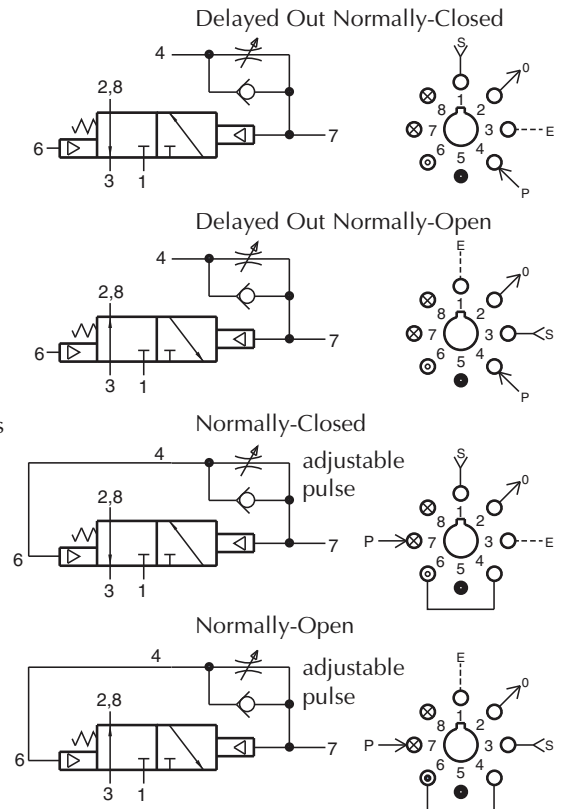



MODULAR MULTIPLE 3-WAY VALVES

R-351

Dual Normally-Closed 3-Way Valve

Features:

- Micro gap construction - snap action and no blow by
- Two independent valves in one module
- Saves space

Performance:

Flow: 9 scfm @ 100 psig; 255 l/min @ 6.9 bars
Pilot Pressure Minimum: 40 psig; 2.8 bars
Temperature: 32 to 180°F
Working Pressure: 0 to 150 psig; 0 to 10.3 bars

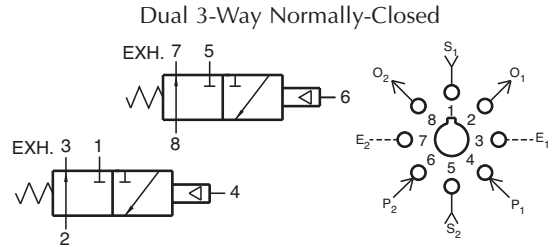

Description:

R-351 is a dual element combination of 2 independent, spring return, 3-way valves in a single manifold, set-up for Normally-Closed usage only. Ports 3 and 7 are exhausts to atmosphere and cannot be restricted.

R-352

Dual 3-Way Valve

Features:

- Micro gap construction - snap action and no blow by
- Two independent units in one module
- Common supply eliminates extra piping

Performance:

Flow: 9 scfm @ 100 psig; 255 l/min @ 6.9 bars
Pilot Pressure Minimum: 40 psig; 2.8 bars
Temperature: 32 to 180°F
Working Pressure: 0 to 150 psig; 0 to 10.3 bars

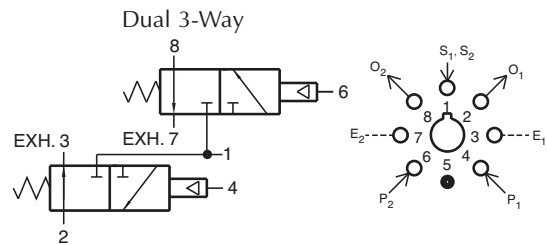

Description:

R-352 is a dual element combination consisting of 2 independent, spring return, 3-way Normally-Closed valves with a common inlet. Ports 3 and 7 are exhausts to atmosphere, and can not be restricted.

MODULAR MULTIPLE 3-WAY VALVES



R-353



Dual 3-Way Valve

Features:

- Micro gap construction - snap action and no blow by
- Complete function in one module
- Auxiliary outputs save fittings and time

Performance:

Flow: 9 scfm @ 100 psig; 255 l/min @ 6.9 bars
Pilot Pressure Minimum: 40 psig; 2.8 bars
Temperature: 32 to 180°F
Working Pressure: 0 to 150 psig; 0 to 10.3 bars

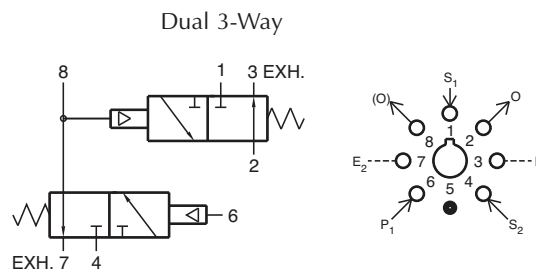

Description:

R-353 is a dual element combination consisting of 2 Normally-Closed, spring return, 3-way valves interconnected to form a 3-input "AND" subcircuit. Ports 3 and 7 are exhausted to atmosphere, and should not be restricted. Ports 1, 4, and 6 are inputs. Output will occur at Port 2 only when all three of these ports are actuated. Port 8 is an auxiliary output and should be plugged if not used.

R-355



Dual Normally-Open 3-Way Valve

Features:

- Micro gap construction - snap action and no blow by
- Two independent units in one module
- Saves space

Performance:

Flow: 9 scfm @ 100 psig; 255 l/min @ 6.9 bars
Pilot Pressure Minimum: 40 psig; 2.8 bars
Temperature: 32 to 180°F
Working Pressure: 0 to 150 psig; 0 to 10.3 bars

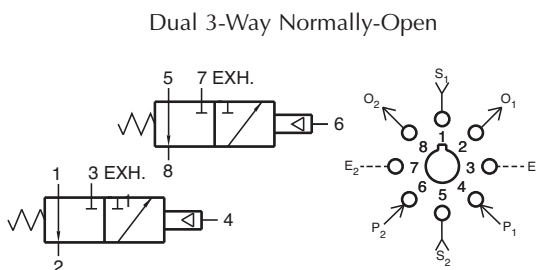

Description:

R-355 is a dual element combination of 2 independent, spring-return, 3-way valves in a single manifold, set-up for Normally-Open usage only. Ports 3 and 7 are exhausts to atmosphere and can not be restricted.



MODULAR 4-WAY VALVES

R-401



4-Way Valve

Features:

- Indicator shows valve in shaded position
- Micro gap construction - snap action and no blow by
- Balanced design allows speed control at exhausts

Performance:

Flow: 9 scfm @ 100 psig; 255 l/min @ 6.9 bars
Pilot Pressure Minimum: 40 psig; 2.8 bars
Temperature: 32 to 180°F
Working Pressure: 0 to 150 psig; 0 to 10.3 bars

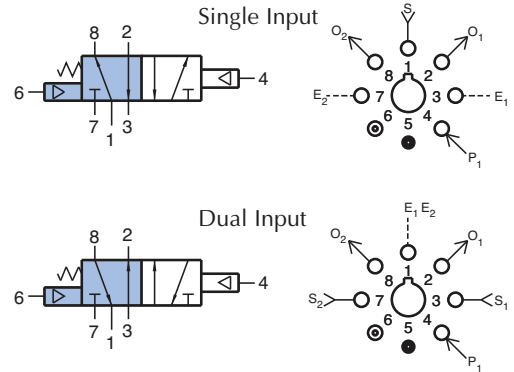

Description:

R-401 is a 4-way, spring return, pilot operated, fully ported 5-ported 4-way valve. R-401 is a versatile component in basic logic circuits, and can perform all 2, 3, and 4-way functions. Operates double acting cylinders, and allows speed control by restricting exhaust ports. It can be used with one input, two independent outputs and two independent exhausts, or with two independent inputs, two independent outputs and a common exhaust. Auxiliary pilot feature.

R-402



4-Way Valve

Features:

- Indicator shows valve in shaded position
- Micro gap construction - snap action and no blow by
- Balanced design allows speed control at exhausts

Performance:

Flow: 9 scfm @ 100 psig; 255 l/min @ 6.9 bars
Pilot Pressure Minimum: 20 psig; 1.4 bars
Temperature: 32 to 180°F
Working Pressure: 0 to 150 psig; 0 to 10.3 bars

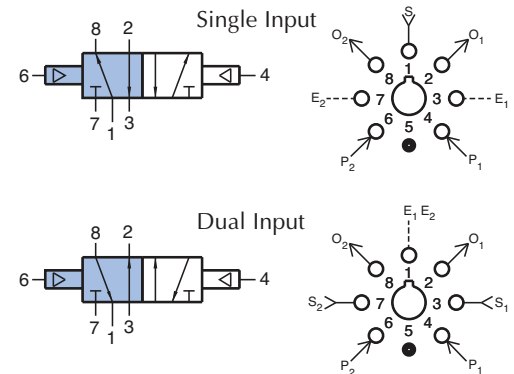

Description:

R-402 is a 4-way, double piloted, fully ported, 2-position valve. R-402 is a versatile component in basic logic circuits, and can perform all 2-, 3-, and 4-way functions. Operates double acting cylinders, and allows speed control by restricting exhaust ports.

R-405



L.P. Pilot Valve

Features:

- Pilot actuates valve with low pressure signal
- Micro gap construction - snap action and no blow by
- Balanced design allows speed control at exhausts

Performance:

Flow: 9 scfm @ 100 psig; 255 l/min @ 6.9 bars
Pilot Pressure Minimum: 15 psig; 1.0 bar
Temperature: 32 to 180°F
Working Pressure: 0 to 150 psig; 0 to 10.3 bars

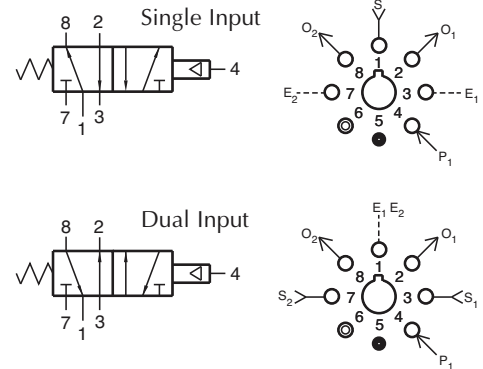

Description:

R-405 is a 4-way, spring-return, fully ported 5-port valve with a low pressure pilot. Pilot pressures as low as 15 psig will actuate the valve. It can perform all 2, 3, and 4-way functions. Operates double acting cylinders, allows speed control by restricting exhaust ports. It can be used with 1 input, 2 independent outputs and two independent exhausts, or with 2 independent inputs, 2 independent outputs and a common exhaust. The R-405 may be used in place of an R-401 where lower pilot actuation pressure is desired.

R-410



4-Way Reset Valve

Features:

- Indicator shows valve in shaded position
- Micro gap construction - snap action and no blow by
- Balanced design allows speed control at exhausts
- Unique piloted spring reset

Performance:

Flow: 9 scfm @ 100 psig; 255 l/min @ 6.9 bars
Pilot Pressure Minimum (against spring): 40 psig; 2.8 bars
Pilot Pressure Minimum (spring retracted): 20 psig; 1.4 bars
Temperature: 32 to 180°F
Working Pressure: 0 to 150 psig; 0 to 10.3 bars

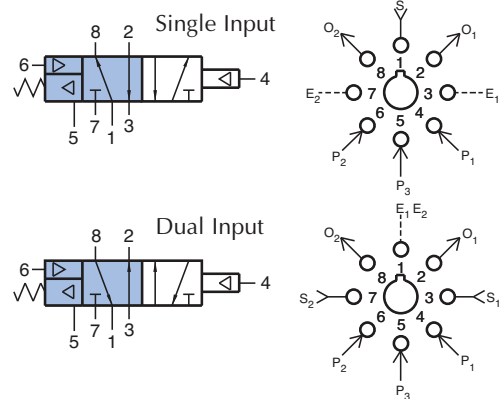

Description:

R-410 is a 4-way, fully ported valve with a special air retracted spring return that will return the valve to a definite position when there is no signal at ports 5 and 4. This "reset" feature may be used in circuits in the event of loss of air pressure or to change the operating characteristics of the valve in the circuit in response to an independent input at port 5. When port 5 is not piloted, the R-410 acts as a R-401 4-way spring return, fully ported valve. When port 5 is actuated, the R-410 acts as an R-402 4-way, two position valve. With no signal at port 5, a signal at port 6 acts as an auxiliary pilot type valve and will override a signal at port 4.



MODULAR 4-WAY VALVES

R-412

4-Way Reset Valve

Features:

- Indicator shows valve in shaded position
- Micro gap construction - snap action and no blow by
- Balanced design allows speed control at exhausts
- Reset feature allows for fail safe circuit design

Performance:

Flow: 9 scfm @ 100 psig; 254 l/min @ 6.9 bars
Pilot Pressure Minimum: 20 psig; 1.4 bars
Temperature: 32 to 180°F
Working Pressure: 0 to 150 psig; 0 to 10.3 bars

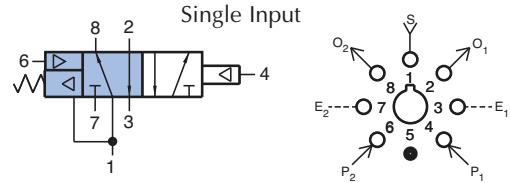

Description:

R-412 is a 5 ported 4-way double piloted, fully ported, 2-position valve with a special air-retracted spring that returns the valve to a definite position when the input air is off. This "memory" feature is ideal for circuitry where a definite starting position is required should the air supply fail and come on again unexpectedly. When there is pressure at port one, the spring pilot compresses the spring and holds it out of the way: valve functions normally as a double piloted 4-way valve identical to the R-402.

R-421

3-Position, 4-Way Valve

Features:

- Micro gap construction - snap action and no blow by
- Three positions
- Balanced design allows speed control at exhausts

Performance:

Flow: 9 scfm @ 100 psig; 255 l/min @ 6.9 bars
Pilot Pressure Minimum: 40 psig; 2.8 bars
Temperature: 32 to 180°F
Working Pressure: 0 to 150 psig; 0 to 10.3 bars

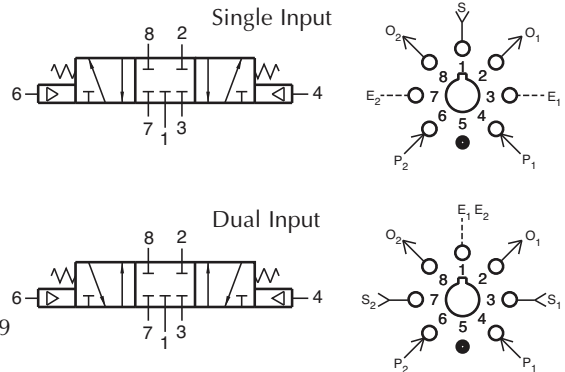

Description:

R-421 is a 4-way, 3-position, spring centered, fully ported valve. In the center position, all ports are blocked. It is ideal for approximate positioning and holding of pneumatic cylinders.

MODULAR 4-WAY TWIN PILOT VALVES



R-431



Twin Pilot 4-Way Valve

Features:

- Indicator shows valve in shaded position
- Micro gap construction - snap action and no blow by
- Dual pilots eliminate shuttle valve
- Balanced design allows speed control at exhausts

Performance:

Flow: 9 scfm @ 100 psig; 255 l/min @ 6.9 bars
Pilot Pressure Minimum: 40 psig; 2.8 bars
Temperature: 32 to 180°F
Working Pressure: 0 to 150 psig; 0 to 10.3 bars

Description:

R-431 is a 5 ported, 4-way valve, with spring return and dual pilots. When ports 5 and 2 are connected, a momentary pilot signal at port 4 will shift the valve to the "latched" position. It will remain in this position until the supply (port 1) is removed, or connection between ports 5 and 2 is interrupted.
 Special Note: R-431 uses differential pilots and, as a result, the auxiliary pilot with the spring is not sufficiently large to cancel out the force of pilot 5. The auxiliary pilot will overcome pilot 4. The valve is actuated by pilot signals per the following chart:

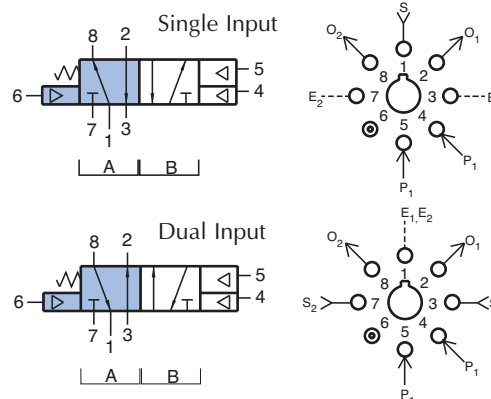

Pilot			Position
6	5	4	
off	off	off	A
off	off	on	B
off	on	on	B
off	on	off	B
on	off	off	A
on	off	on	A
on	on	off	B*

*Dependent on pressure relation of port 5 and 6

R-432



Twin Pilot 4-Way Valve

Features:

- Indicator shows valve in shaded position
- Micro gap construction - snap action and no blow by
- Dual pilots eliminate shuttle valve
- Balanced design allows speed control at exhausts

Performance:

Flow: 9 scfm @ 100 psig; 255 l/min @ 6.9 bars
Pilot Pressure Minimum: 20 psig; 1.4 bars
Temperature: 32 to 180°F
Working Pressure: 0 to 150 psig; 0 to 10.3 bars

Description:

R-432 is a 5 ported, 4-way, two position, double piloted valve.

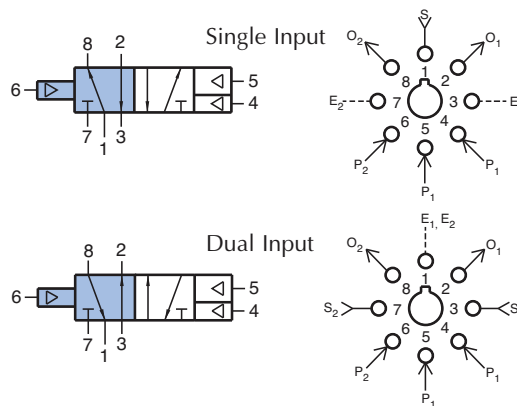



MODULAR 4-WAY TWIN PILOT VALVES

R-433



Twin Pilot 4-Way Valve

Features:

- Indicator shows valve in shaded position
- Micro gap construction - snap action and no blow by
- Dual pilots eliminate shuttle valve
- Balanced design allows speed control at exhausts

Performance:

Flow: 9 scfm @ 100 psig; 255 l/min @ 6.9 bars
Pilot Pressure Minimum: 40 psig; 2.8 bars
Temperature: 32 to 180°F
Working Pressure: 0 to 150 psig; 0 to 10.3 bars

Description:

R-433 is a 5 ported, 4-way valve, with spring return and dual pilots.

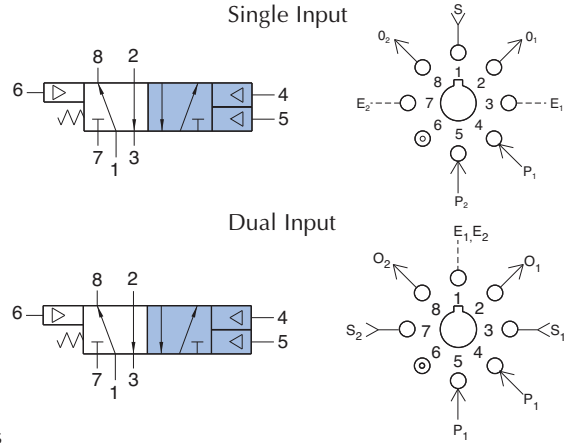

R-434



Twin Pilot 4-Way Valve

Features:

- Indicator shows valve in shaded position
- Micro gap construction - snap action and no blow by
- Dual pilots eliminate shuttle valve
- Balanced design allows speed control at exhausts

Performance:

Flow: 9 scfm @ 100 psig; 255 l/min @ 6.9 bars
Pilot Pressure Minimum: 20 psig; 1.4 bars
Temperature: 32 to 180°F
Working Pressure: 0 to 150 psig; 0 to 10.3 bars

Description:

R-434 is a 5 ported, 4-way, two position, double piloted valve.

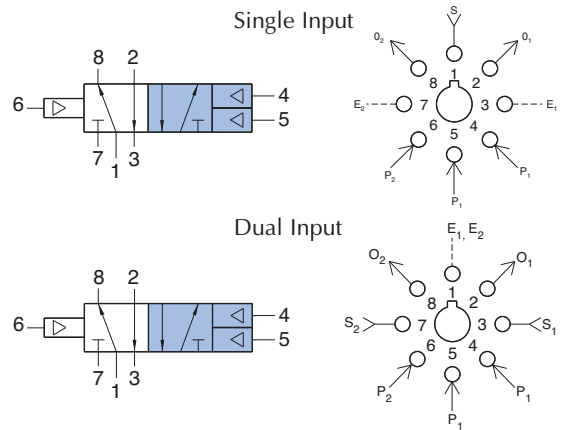

MODULAR 4-WAY DUAL TWIN PILOT VALVES



R-436

Dual Twin Pilot 4-Way Valve



Features:

- Micro gap construction - snap action and no blow by
- Dual pilots eliminate shuttle valve
- Balanced design allows speed control at exhausts

Performance:

Flow: 9 scfm @ 100 psig; 255 l/min @ 6.9 bars

Pilot Pressure Minimum: 20 psig; 1.4 bars

Temperature: 32 to 180°F

Working Pressure: 0 to 150 psig; 0 to 10.3 bars

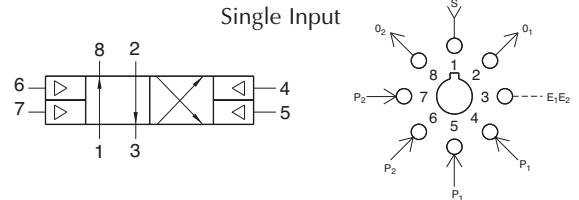

Description:

R-436 is a 4-way, two position valve with two pilots on each side. Actuating more than one pilot on the same side has no additional effect. Pilot signals must be absent from all pilots on one side before an opposite pilot will shift the valve. Port 3 is used as a common exhaust path.

Pneumatic Liquid Dispenser

Clippard Modular Valve Circuit with Adjustable Pressure and Auto Sequencing Control allows for no drip, metered dispensing.

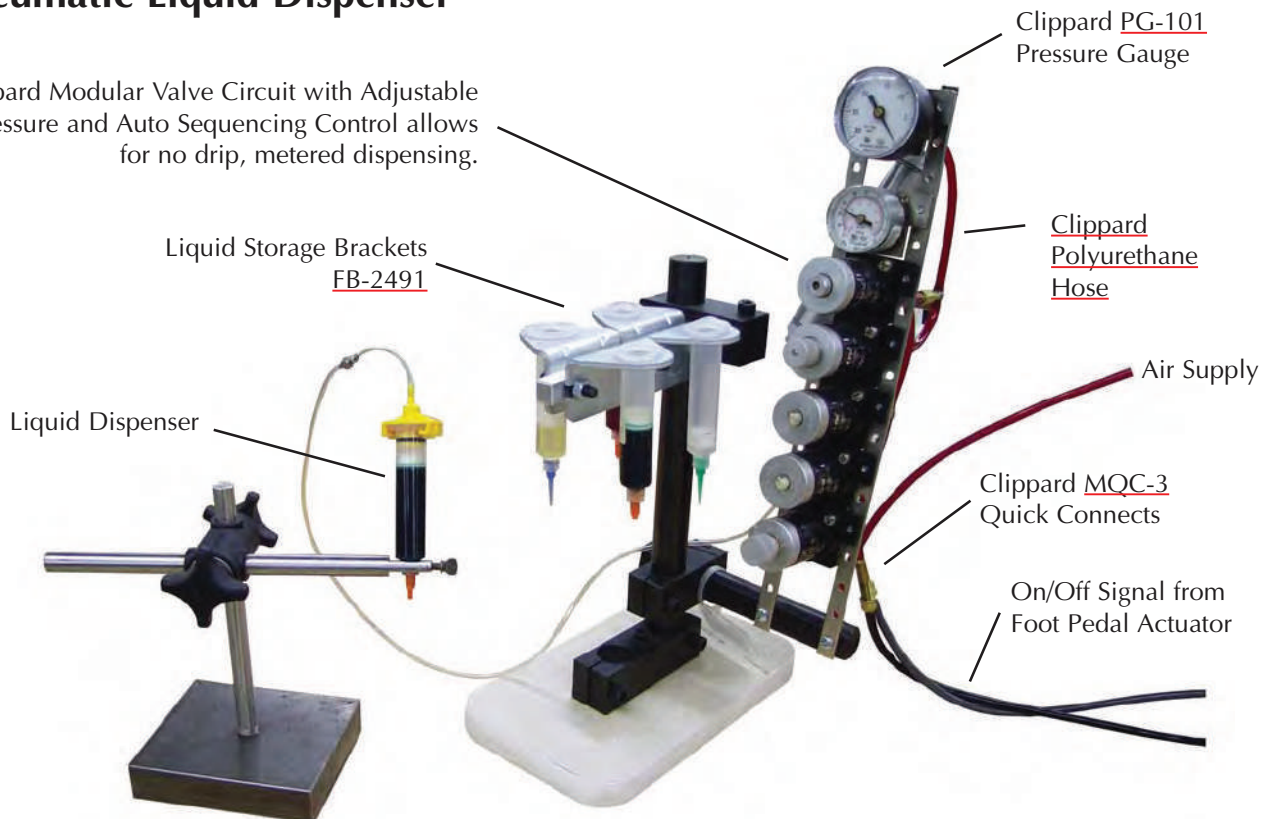

This device precisely meters small amounts of liquids to parts with no drip or mess. It is made entirely of Clippard components.



MODULAR 4-WAY BLEED PILOT VALVES

R-441



4-Way Valve

Features:

- Indicator shows valve in shaded position
- Micro gap construction - snap action and no blow by
- Balanced design allows speed control at exhausts

Performance:

Flow: 9 scfm @ 100 psig; 255 l/min @ 6.9 bars
Pilot Pressure Minimum: 40 psig; 2.8 bars
Temperature: 32 to 180°F
Working Pressure: 0 to 150 psig; 0 to 10.3 bars

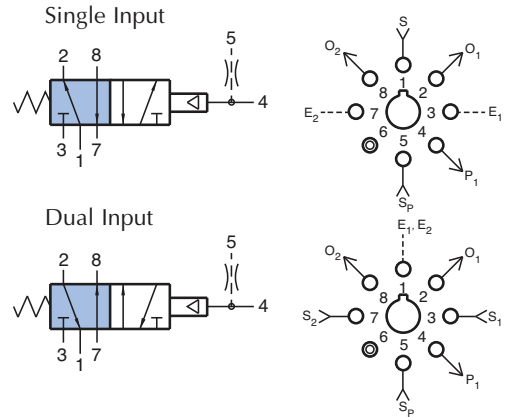

Description:

R-441 is a 4-way, spring return, bleed piloted valve for use with simple low force sensors. The vent supply pressure is independent of the inlet pressure to the valve. This pilot supply passes through a built-in restriction and shifts the valve compressing the spring. Venting (exhausting) the pressure in the pilot chamber (faster than the restricted supply can recover) shifts the valve.

R-442



4-Way Valve

Features:

- Indicator shows valve in shaded position
- Micro gap construction - snap action and no blow by
- Balanced design allows speed control at exhausts

Performance:

Flow: 9 scfm @ 100 psig; 255 l/min @ 6.9 bars
Pilot Pressure Minimum: 20 psig; 1.4 bars
Temperature: 32 to 180°F
Working Pressure: 0 to 150 psig; 0 to 10.3 bars

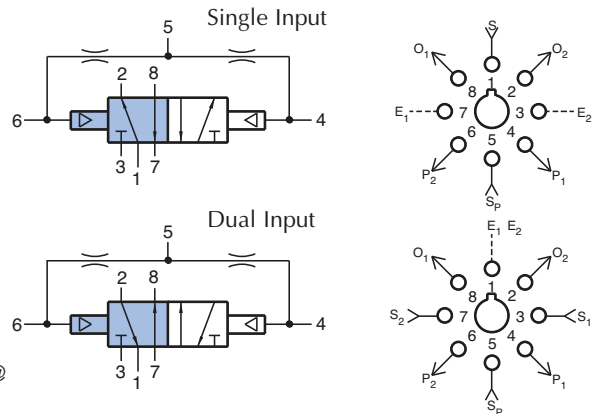

Description:

R-442 is a 4-way, double bleed pilot valve. The vent supply pressure is independent of the inlet pressure to the valve. Pilot supply passes through built-in restrictions and pressurizes both pilots. Venting (exhausting) the pressure in one pilot chamber (faster than the restricted supply can recover) causes the valve to be shifted by the opposite pilot.

MODULAR 4-WAY DELAY VALVES



R-443



4-Way Delay Valve

Features:

- Micro gap construction - snap action and no blow by
- Screwdriver slot needle adjustment deters tampering
- Balanced design allows speed control at exhausts

Performance:

Flow: 9 scfm @ 100 psig; 255 l/min @ 6.9 bars
Pilot Pressure Minimum: 40 psig; 2.8 bars
Temperature: 32 to 180°F
Working Pressure: 0 to 150 psig; 0 to 10.3 bars

Description:

R-443 is a 4-way, spring return, fully ported 5-port valve with an adjustable flow control valve interconnected to the pilot. A pilot input signal in port 4 actuates the valve. When the pilot signal is exhausted it is delayed, out keeping the valve actuated until the pilot pressure has decayed. The R-443 can perform all 2-, 3-, and 4-way functions. The R-443 also features an auxiliary pilot on the spring side of the valve. Port 5 is an auxiliary for adding volume for longer time delays, if not used, port 5 should be plugged.

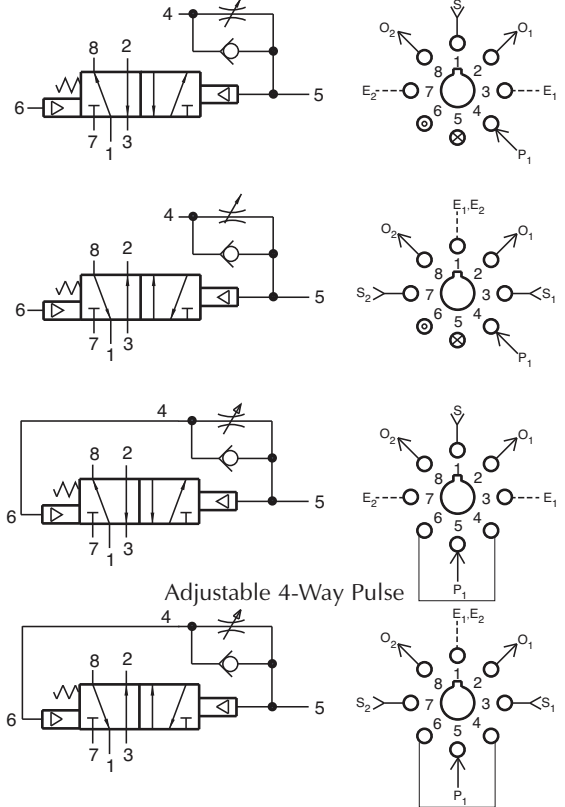

R-445



4-Way Delay Valve

Features:

- Micro gap construction - snap action and no blow by
- Screwdriver slot needle adjustment deters tampering
- Balanced design allows speed control at exhausts

Performance:

Flow: 9 scfm @ 100 psig; 255 l/min @ 6.9 bars
Pilot Pressure Minimum: 40 psig; 2.8 bars
Temperature: 32 to 180°F
Working Pressure: 0 to 150 psig; 0 to 10.3 bars

Description:

R-445 is a 4-way, spring return, fully ported, 5-port valve with an adjustable needle valve connected in parallel to the pilot. A pilot signal input in port 4 will be delayed in before actuating the valve. When the pilot signal is exhausted it is delayed out keeping the valve actuated until the pilot pressure has decayed. The R-445 can perform all 2-, 3-, and 4-way functions. The R-445 also features an auxiliary pilot on the spring side of the valve. It can also be used as a bleed pilot by a constant supply to 4 and connecting port 5 to a bleed valve.

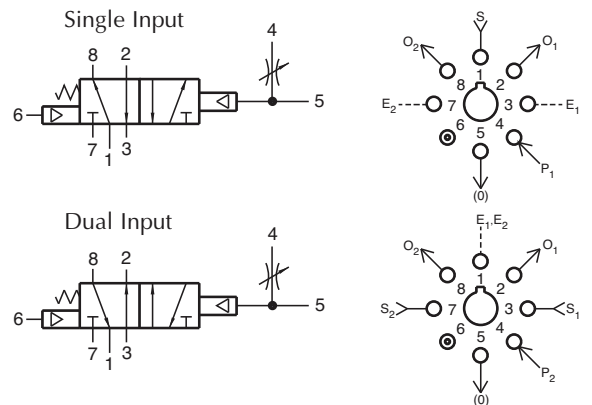



MODULAR 4-WAY VALVES

R-451



Binary Trigger Valve

Features:

- Micro gap construction - snap action and no blow by
- Dual pilots eliminate shuttle valve
- Balanced design allows speed control at exhausts

Performance:

Flow: 9 scfm @ 100 psig; 255 l/min @ 6.9 bars
Pilot Pressure Minimum: 40 psig; 2.8 bars
Temperature: 32 to 180°F
Working Pressure: 0 to 150 psig; 0 to 10.3 bars

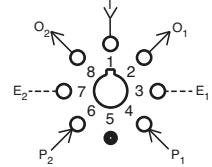
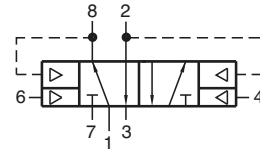

Description:

R-451 is a special purpose valve designed to work in conjunction with the R-402/R-412 valve to provide a single input flip-flop (binary sub-circuit).

R-453



4-Way Delay Valve

Features:

- Micro gap construction - snap action and no blow by
- Screwdriver slot needle adjustment deters tampering
- Balanced design allows speed control at exhausts

Performance:

Flow: 9 scfm @ 100 psig; 255 l/min @ 6.9 bars
Pilot Pressure Minimum: 40 psig; 2.8 bars
Temperature: 32 to 180°F
Working Pressure: 0 to 150 psig; 0 to 10.3 bars

Single Input

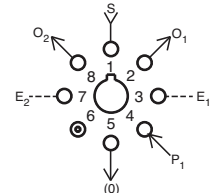
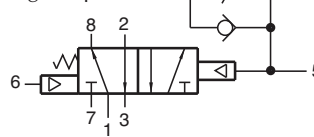

Dual Input

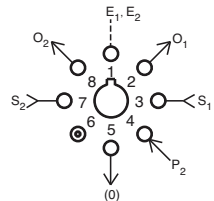
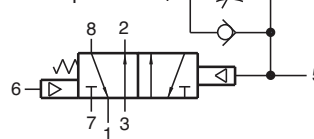

Description:

R-453 is a 4-way, spring return, fully ported 5 port valve with an adjustable flow control valve interconnected to the pilot. A pilot signal input in port 4 will be delayed in before actuating the valve. When the pilot signal is exhausted, the spring shifts the valve. The R-453 can perform all 2-, 3-, and 4-way functions. The R-453 also features an auxiliary pilot on the spring side of the valve.

MODULAR 4-WAY DELAY VALVES



R-454



4-Way Delay Valve

Features:

- Micro gap construction - snap action and no blow by
- Screwdriver slot needle adjustment deters tampering
- Balanced design allows speed control at exhausts

Performance:

Flow: 9 scfm @ 100 psig; 255 l/min @ 6.9 bars
Pilot Pressure Minimum: 40 psig; 2.8 bars
Temperature: 32 to 180°F
Working Pressure: 0 to 150 psig; 0 to 10.3 bars

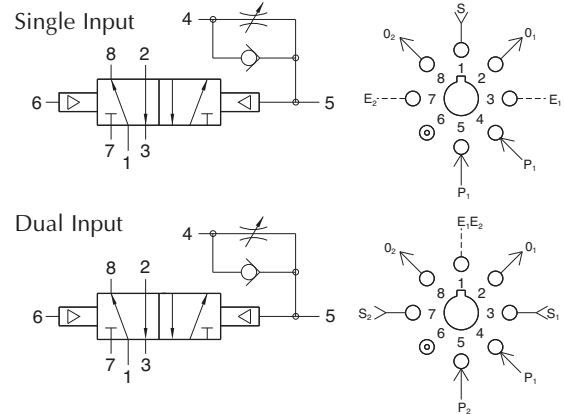

Description:

R-454 is a 4-way, double pilot, fully ported 5 port valve with an adjustable flow control valve interconnected to one pilot. A pilot signal input in port 4 will be delayed in before actuating the valve. The R-454 can perform all 2-, 3- and 4-way functions.

R-461



4-Way Valve, 6-Ported

Features:

- Indicator shows valve in shaded position
- Micro gap construction - snap action and no blow by
- Balanced design allows speed control at exhausts

Performance:

Flow: 9 scfm @ 100 psig; 255 l/min @ 6.9 bars
Pilot Pressure Minimum: 40 psig; 2.8 bars
Temperature: 32 to 180°F
Working Pressure: 0 to 150 psig; 0 to 10.3 bars

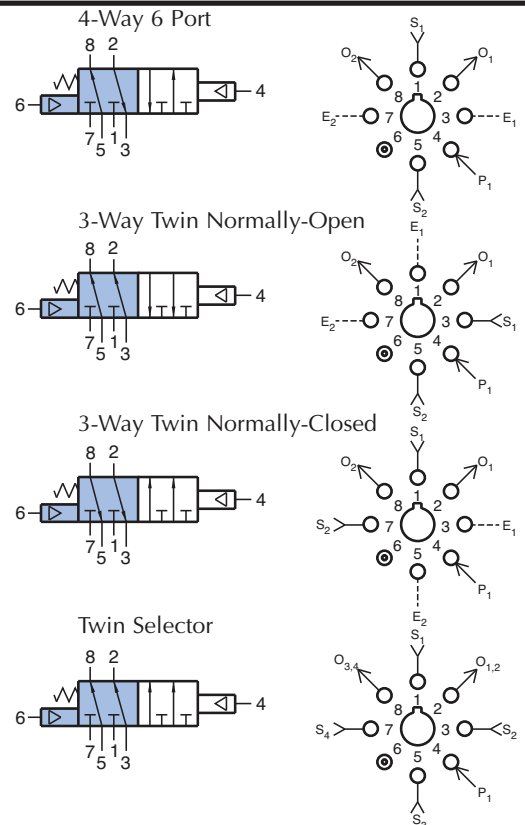

Description:

R-461 is a 6-ported, 4-way, spring return, fully ported, pilot operated valve. It is basically two fully ported 3-way valves with a common pilot. It can be used in a variety of applications including dual pressure operations with two independent inlets, outlets, and exhausts.



MODULAR 4-WAY VALVES

R-462

4-Way Valve, 6-Ported

Features:

- Indicator shows valve in shaded position
- Micro gap construction - snap action and no blow by
- Balanced design allows speed control at exhausts

Performance:

Flow: 9 scfm @ 100 psig; 255 l/min @ 6.9 bars
Pilot Pressure Minimum: 20 psig; 1.4 bars
Temperature: 32 to 180°F
Working Pressure: 0 to 150 psig; 0 to 10.3 bars



Description:

R-462 is a 6-ported, 4-way, double piloted, fully ported, two position valve. It is basically two fully ported 3-way valves with a common pilot. It can be used in a variety of applications including dual pressure operations with two independent inlets, outlets and exhausts.

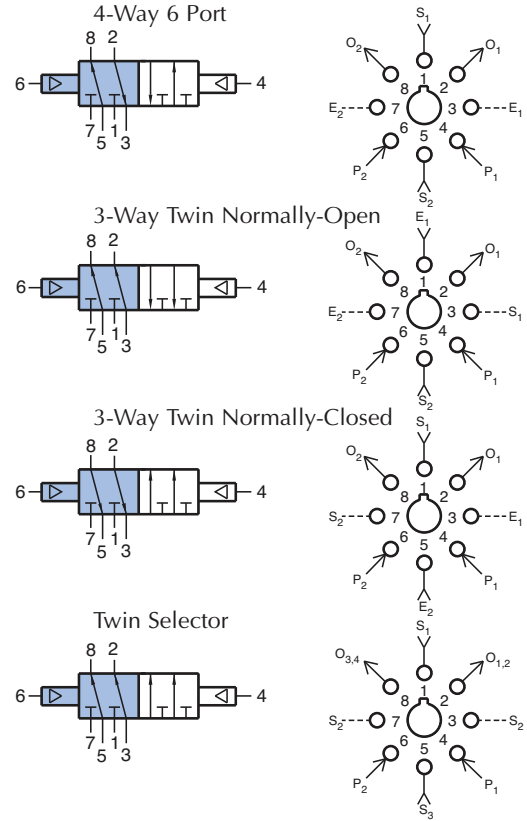

R-465

Low Pressure 4-Way Valve, 6-Ported

Features:

- Pilot actuates valve with low pressure signal
- Multiple porting speeds piping
- Micro gap construction - snap action and no blow by
- Balanced design allows speed control at exhausts

Performance:

Flow: 9 scfm @ 100 psig; 255 l/min @ 6.9 bars
Pilot Pressure Minimum: 15 psig; 1.0 bar
Temperature: 32 to 180°F
Working Pressure: 0 to 150 psig; 0 to 10.3 bars



Description:

R-465 is a 6-ported, 4-way, spring-return, fully ported valve with a low pressure pilot. Pilot pressures as low as 15 psig will actuate the valve. It is basically two fully ported 3-way valves with a common low pressure pilot. It can be used in a variety of applications including dual pressure operation, with two independent inlets, outlets and exhausts. The R-465 may be used in place of an R-461 where a lower pilot actuation pressure is desired.

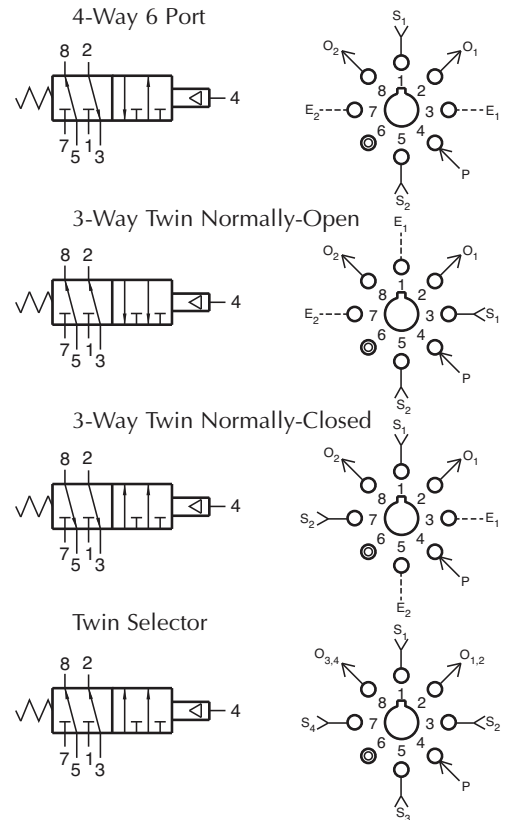

MODULAR 4-WAY AMPLIFIED PILOT VALVES



R-471



4-Way Amplified Pilot Valve

Features:

- Micro gap construction - snap action and no blow by
- Clippard 3200 bleed type amplifier section assures long life and repeatability
- Standard octoport plug-in design

Performance:

Flow: 9 scfm @ 100 psig; 255 l/min @ 6.9 bars

Pilot Pressure (psig) Minimum: 8" H₂O on 1" H₂O off

Pilot Supply Pressure: 45 to 100 psig; 3.1 to 6.9 bars

Temperature: 32 to 180°F

Working Pressure: 0 to 150 psig; 0 to 10.3 bars

Bleed Flow (amplifier orifice): 0.010" (0.25)

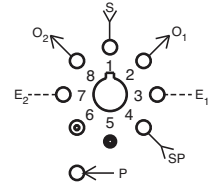
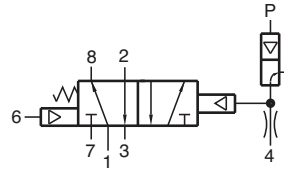

Description:

R-471 is a 4-way, fully ported, spring return, amplified pilot valve. The R-471 is a hybrid combination of the R-401 and model 3200 snap action valve.

R-472



4-Way Interface Valve

Features:

- Micro gap construction - snap action and no blow by
- Clippard 3200 bleed type amplifier section assures long life and repeatability
- Standard octoport plug-in design

Performance:

Flow: 9 scfm @ 100 psig; 255 l/min @ 6.9 bars

Pilot pressure (psig) Minimum: 8" H₂O on 1" H₂O off

Pilot Supply Pressure: 45 to 100 psig; 3.1 to 6.9 bars

Temperature: 32 to 180°F

Working Pressure: 0 to 150 psig; 0 to 10.3 bars

Bleed Flow (amplifier orifice): 0.010" (0.25)

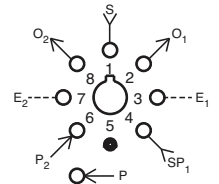
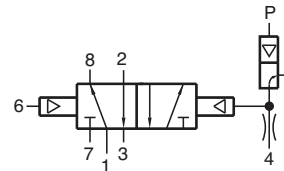

Description:

R-472 is a 4-way, fully ported, two position, amplified pilot valve. R-472 is a hybrid combination of the R-402 and model 3200 snap action valve.



MODULAR 4-WAY ELECTRONICALLY PILOTED VALVES

R-481-□



Electronic Valve

Features:

- Extremely low power consumption
- Micro gap construction - snap action and no blow by
- Standard octoport plug-in design
- Provides interface between electronics and pneumatics

Performance:

Working Range: 0 to 150 psig; 0 to 10.3 bars

Flow: 9 scfm @ 100 psig; 255 l/min @ 6.9 bars

Pilot Pressure (on port 4): 40 to 105 psig; 2.8 to 7.2 bars

Temperature: 32 to 180°F

Power Consumption: 0.65 watt at rated voltage

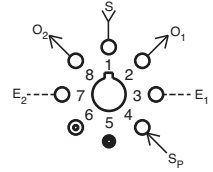
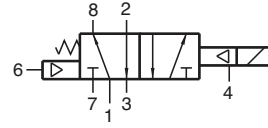

Voltage	R-481-6	6 VDC
	R-481-12	12 VDC
	R-481-24	24 VDC

Duty: Continuous duty at 150% of rated voltage (50% overload) permissible

Description:

R-481 is a fully ported (5-ported), 4-way valve. It is essentially a hybrid valve consisting of the R-401 valve and the Clippard model ET-3 electronic/pneumatic valve. The ET-3 responds to low current, low voltage signals and pneumatically actuates the R-401 4-way valve to which it is attached. A 40 psig pilot pressure must be present at port 4.

R-482-□



Electronic Valve

Features:

- Extremely low power consumption
- Micro gap construction - snap action and no blow by
- Standard octoport plug-in design
- Provides interface between electronics and pneumatics

Performance:

Working Range: 0 to 150 psig; 0 to 10.3 bars

Flow: 9 scfm @ 100 psig; 255 l/min @ 6.9 bars

Pilot Pressure: 20 to 105 psig; 1.4 to 7.2 bars

At Port 6 (min): 20

Temperature: 32 to 180°F

Power Consumption: 0.65 watt at rated voltage

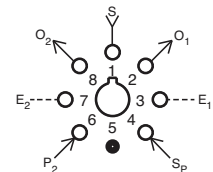
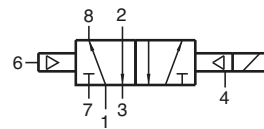

Voltage	R-482-6	6VDC
	R-482-12	12VDC
	R-482-24	24VDC

Duty: Continuous duty at 150% of rated voltage (50% overload) permissible

Description:

R-482 is a fully ported (5-ported), 4-way valve. It is essentially a hybrid valve consisting of the R-402 valve and the Clippard model ET-3 electronic/pneumatic valve. The ET-3 responds to low current, low voltage signals and pneumatically actuates the R-402 4-way valve to which it is attached. A 20 psig pilot pressure must be present at port 4.



R-501 R-502



Flow Control Valve

Features:

- Multiple porting speeds piping
- Knurled knob for fast, accurate adjustments - no tools needed
- Fine adjustment for pneumatic timing

Performance:

Flow: 0 to 1 scfm @ 100 psig; 0 to 28.3 l/min

Temperature: 32 to 180°F

Working Pressure: 0 to 150 psig; 0 to 10.3 bars

R-501 Delay In Flow Control

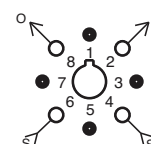
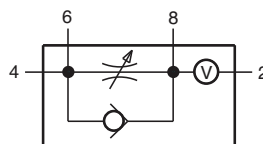

R-502 Delay Out Flow Control

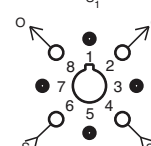
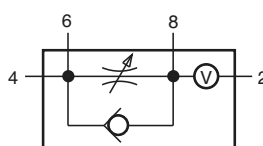

Description:

R-501 is an adjustable flow control designed to meter "IN" to an integral volume chamber to delay pressure build-up in one direction. Dual ports are provided to add extra volume or for multiple input-output connections.

R-502 is an adjustable flow control designed to meter "OUT" from an integral volume chamber to delay pressure decay in one direction.

R-602 R-603



Dual Shuttle Valves

Features:

- R-602**
 - Bubble tight operation
 - Two independent units in one module
 - Saves space
- R-603**
 - Complete three input subcircuit in one module
 - Auxiliary outputs save fittings and time

Performance:

Flow: 10 scfm @ 100 psig; 283 l/min @ 6.9 bars

Temperature: 32 to 180°F

Working Pressure: 5 to 150 psig; 0.3 to 10.3 bars

R-602 Dual Shuttle Valve

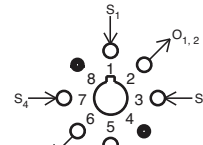
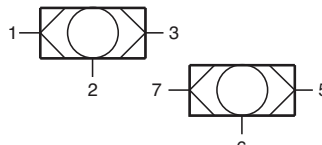

R-603 3-Input "OR"

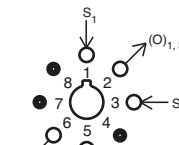
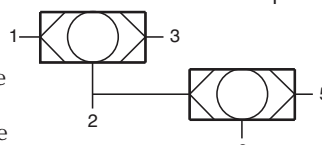

Description:

R-602 is a dual element combination consisting of two completely independent shuttle valves in a single body.

R-603 is a dual element combination consisting of two shuttle valves which are interconnected into a subcircuit. It provides a 3-input "or" with port 2 available as an auxiliary. If not used, port 2 should be plugged.



MODULAR REGULATOR & PULSE VALVES

R-701

Pressure Regulator



Features:

- Multiple porting speeds piping
- Knurled knob for fast, accurate adjustments - no tools needed
- Self-relieving

Performance:

Flow: 12 scfm @ 100 psig; 340 l/min @ 6.9 bars

Temperature: 32 to 180°F

Working Pressure: 0 to 150 psig; 0 to 10.3 bars

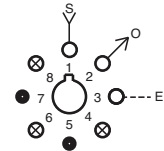
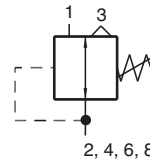

Description:

R-701 is a self-relieving, adjustable pressure regulator with multiple output ports. Pressure can be piped directly from ports 2, 4, 6 and 8. Eliminates need for additional fittings. Unused output ports should be plugged.

R-711

Pulse Valve



Features:

- Multiple porting speeds piping
- Micro Gap Construction - snap action and no blow by
- Complete function in one module

Performance:

Flow: 10 scfm @ 100 psig; 283 l/min @ 6.9 bars

Pilot Pressure Minimum: 40 psig; 2.8 bars

Temperature: 32 to 180°F

Working Pressure: 40 to 150 psig; 2.8 to 10.3 bars

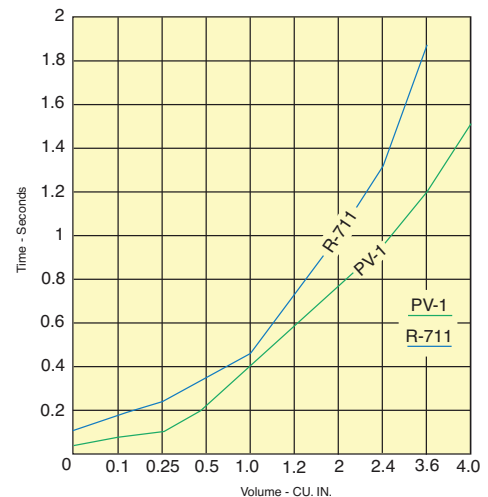
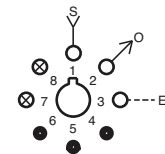
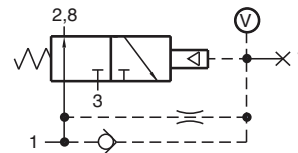

Volume	Time in Seconds		Volume	Time in Seconds	
	PV-1	R-711		PV-1	R-711
0	0.042	0.117	1.2	0.580	0.700
0.1	0.074	0.180	2.0	0.760	1.000
0.25	0.124	0.245	2.4	0.950	1.300
0.5	0.210	0.350	3.6	1.200	1.900
1.0	0.390	0.450	4.0	1.500	N.R.

Description:

R-711 is a 3-way, Normally-Open, self-piloted valve that closes shortly after being pressurized and remains closed until signal pressure is exhausted. It converts a continuous input signal into a single pulse of approximately 50 milliseconds. Port 7 is provided for additional volume for extending pulse duration and should be plugged if not used.

R-731



Modular Vacuum Generator

Turn pressure to vacuum generator on/off

Features:

- Indicator shows valve in shaded position
- Micro gap construction - snap action and no blow by

Performance:

3-Way Valve

Flow: 9 scfm @ 100 psig; 255 l/min @ 6.9 bars

Pilot Pressure Minimum: 40 psig; 2.8 bars

Temperature: 32 to 180°F

Working Pressure: 0 to 150 psig; 0 to 10.3 bars

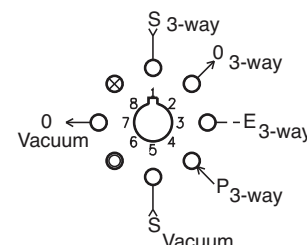
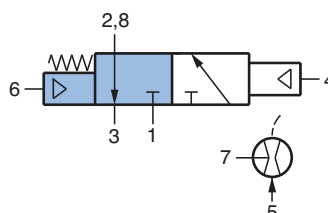

Vacuum Generator

Vacuum (in. Hg @ 60 psig): 25

Vacuum Flow: 0.6 scfm @ 60 psig; 17 l/min @ 4.1 bars

Air Consumption: 1.7 scfm @ 60 psig; 48 l/min @ 4.1 bars

Temperature: 32 to 180°F

Description:

The R-731 is a combination venturi vacuum generator and an independent pilot actuated, spring return, fully ported 3-way valve. Applying pressure at port 5 creates a vacuum at port 7. The 3-way valve can be used to turn the vacuum generator on or off or it can be used to switch the vacuum on or off. 40 psig is required to pilot the 3-way valve.

For mounting and muffler information see [page 270](#).

R-732



Modular Vacuum Generator

Select Pressure or Vacuum Output

Features:

- Indicator shows valve in shaded position
- Micro gap construction - snap action and no blow by

Performance:

3-Way Valve

Flow: 9 scfm @ 100 psig; 255 l/min @ 6.9 bars

Pilot Pressure Minimum: 20 psig; 1.4 bars

Temperature: 32 to 180°F

Working Pressure: 0 to 150 psig; 0 to 10.3 bars

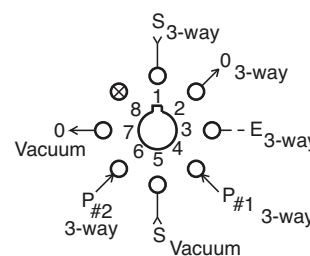
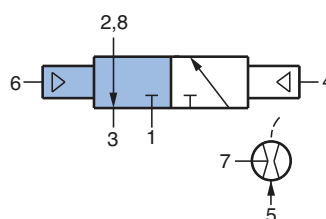

Vacuum Generator

Vacuum (in. Hg @ 60 psig): 25

Vacuum Flow: 0.6 scfm @ 60 psig; 17 l/min @ 4.1 bars

Air Consumption: 17 scfm @ 60 psig; 48 l/min @ 4.1 bars

Temperature: 32 to 180°F

Description:

The R-732 is a combination venturi vacuum generator and an independent double pilot actuated, fully ported 3-way valve. Applying pressure at port 5 creates a vacuum at port 7. The 3-way valve can be used to turn the vacuum generator on or off or it can be used to switch the vacuum on or off. 20 psig is required to pilot the 3-way valve.

For mounting and muffler information see [page 270](#).



VACUUM GENERATOR

R-781-□



Modular Vacuum Generator

Turn Vacuum on/off

Features:

- Micro gap construction - snap action and no blow by

Performance:

3-Way Valve

- Flow:** 9 scfm @ 100 psig; 255 l/min @ 6.9 bars
- Pilot Pressure Minimum:** 20 psig; 1.4 bars
- Temperature:** 32 to 180°F
- Working Pressure:** 0 to 150 psig; 0 to 10.3 bars

Vacuum Generator

- Vacuum (in. Hg @ 60 psig):** 25
- Vacuum Flow (scfm @ 60 psig):** 0.6
- Air Consumption (scfm @ 60 psig):** 1.7
- Temperature:** 32 to 180°F
- Available Voltage:** 6, 12, 24 VDC

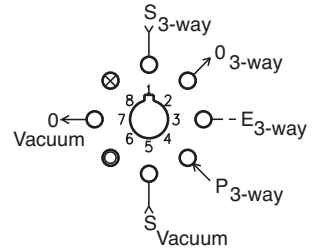
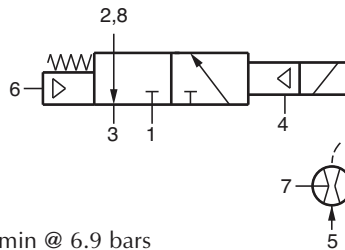

Voltage	<u>R-781-6</u>	6 VDC
	<u>R-781-12</u>	12 VDC
	<u>R-781-24</u>	24 VDC

Power Consumption: 0.65 W @ rated voltage
Duty: Continuous duty to 150% of rated voltage

Description:

R-781 is a combination venturi vacuum generator and an independent pilot actuated electronically controlled, spring return, fully ported 3-way valve. Applying pressure at port 5 creates a vacuum at port 7. The 3-way valve can be used to turn the vacuum generator on or off or it can be used to switch the vacuum on or off. To shift the 3-way valve 40 psig is required at port 4 along with the appropriate DC voltage being applied to the solenoid.

R-782-□



Modular Vacuum Generator

Features:

- Micro gap construction - snap action and no blow by

Performance:

3-Way Valve

- Flow:** 9 scfm @ 100 psig; 255 l/min @ 6.9 bars
- Pilot Pressure Minimum:** 20 psig; 1.4 bars
- Temperature:** 32 to 180°F
- Working Pressure:** 0 to 150 psig; 0 to 10.3 bars

Vacuum Generator

- Vacuum (in. Hg @ 60 psig):** 25
- Vacuum Flow:** 0.6 scfm @ 60 psig
- Air Consumption:** 1.7 scfm @ 60 psig
- Temperature:** 32 to 180°F
- Available Voltage:** 6, 12, 24 VDC

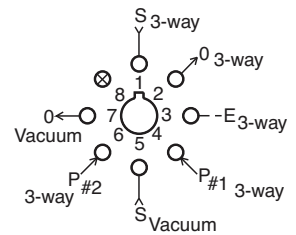
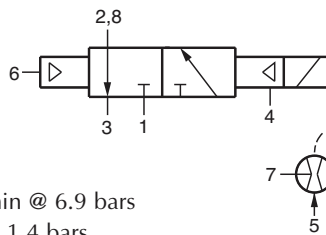

Voltage	<u>R-782-6</u>	6 VDC
	<u>R-782-12</u>	12 VDC
	<u>R-782-24</u>	24 VDC

Power Consumption: 0.65 W @ rated voltage
Duty: Continuous duty to 150% of rated voltage

Description:

The R-782 is a combination venturi vacuum generator and an independent pilot actuated electronically controlled, air pilot return, fully ported 3-way valve. Applying pressure at port 5 creates a vacuum at port 7. The 3-way valve can be used to turn the vacuum generator on or off or it can be used to switch the vacuum on or off. To shift the 3-way valve 20 psig is required at port 4 along with the appropriate DC voltage being applied to the solenoid. To return the valve a pilot pressure of 20 psig is required at port 6.

MODULAR VACUUM GENERATOR



The Modular Vacuum Generator is a combination venturi vacuum generator and 3-way valve, contained in a modular body for simplicity and ease of installation. This combination allows the user to control the pressure to the vacuum generator, vacuum from the generator, and other circuit functions as required.

With 60 psig air to the modular generator, a vacuum of 25 in. Hg and 0.6 scfm is generated from the outlet. This vacuum may be used for pick, place, and hold applications, or liquid drawback circuits and is an energy efficient alternative to both electric and multi-stage air powered pumps.

The venturi vacuum generator provides a low cost vacuum source with no required maintenance. It contains a large flow path in a design that is self-cleaning, eliminating the need for a filtered air supply.

The 3-way valve is a proven Clippard modular valve design utilizing micro gap construction for a very short stroke of the balanced spool.

The Clippard modular vacuum generator uses a Delrin® body with a central valve cavity surrounded by (8) independent air passages that terminate at the base of the body in a circular, octoport pattern. The body mates with a manifold subplate (sold separately) that mounts the complete module and provides #10-32 tapped holes for standard hose fittings. A single octoport gasket (included with the module), held in place by two mounting screws, insures a positive seal.

Performance: Clippard modular vacuum generators provide high vacuum flow with high vacuum levels and are field adjustable. The adjustment screw at the base of the modular allows setting to the optimum performance needed to perform the task.

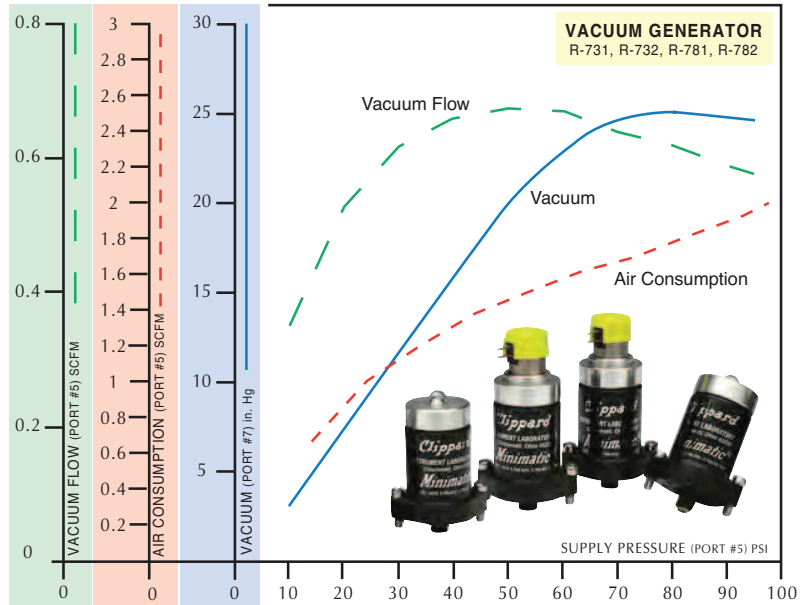

Muffler 3849-1



The 3849-1 muffler is constructed of durable polyethylene with a 1/8" NPT male thread which installs in the extension of either the R-101-10 or R-111-10 subplate.

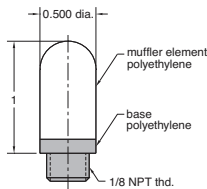

Gauge VG-30



Inlet Vacuum: scale reading from 0 to -30 in. Hg. & 0 to -1 bar

Construction: black case, plastic face, dial shows two ranges; in. Hg in black, bars in red; built-in pressure snubber

Ports: connection located at rear is threaded both O.D. - male thread 1/8" NPT I.D. - tapped for #10-32 fitting

Mounting: Stud mount using 1/8" NPT center stud or panel mount using the zinc plated steel bracket supplied.

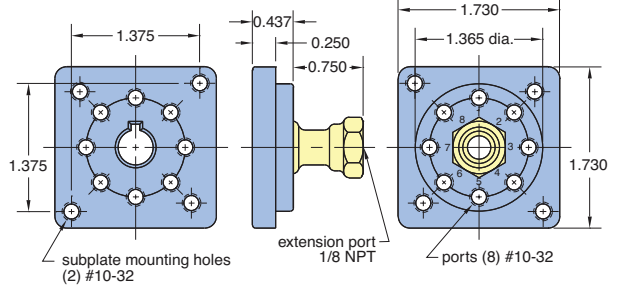
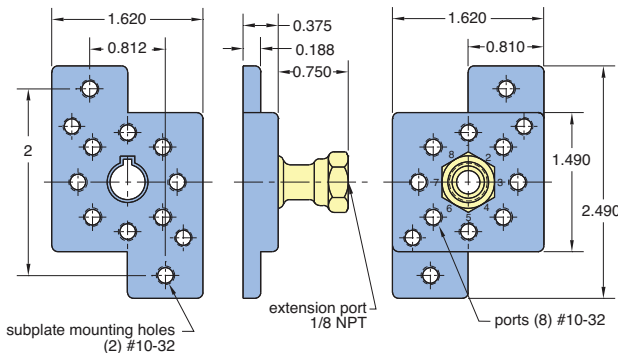

Subplate Dimensions

The **R-101-10** subplate mounts to mounting strips with #10-32 screws and lockwashers provided. Ports on module base are numbered in the same pattern as on the subplate, making piping easy to identify. Module stem is keyed to fit center hole in subplate; assures fast insertion and proper positioning.

R-111-10 subplate mounts in 1 3/8" hole in electrical box, control panel. Mounting screws and gasket provided seal subplate to mounting plate.

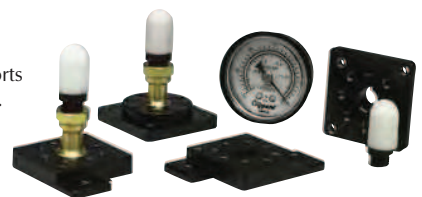



MODULAR VOLUME CHAMBER, FILTER & SEQUENCE VALVE

R-801



Filter

Features:

- Multiple porting speeds piping
- Clean out port for easy maintenance
- Protects system - assures proper functioning
- Replaceable filter element (Part no. R-801-14)

Performance:

Flow: 12 scfm @ 100 psig; 339 l/min @ 6.9 bars

Temperature: 32 to 180°F

Working Pressure: 0 to 150 psig; 0 to 10.3 bars

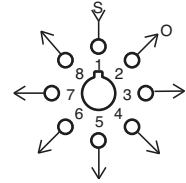
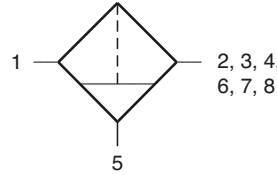

Description:

R-801 is a 25 micron filter with multiple outlets at ports 2, 3, 4, 6, 7 and 8 to minimize need for fittings. Port 5 is a drain and should be plugged; however, when the valve is mounted vertically port 5 can be tubed to a drain. Unused ports should be plugged.

R-811



Connector

Connects to subplate R-101/R101-M5, R-111/R-111-M5 and manifolds

Description:

R-811 is an octoport connector that provides rapid and accurate connection of up to eight hoses. Truly a convenience connection; saves time; eliminates mistakes.

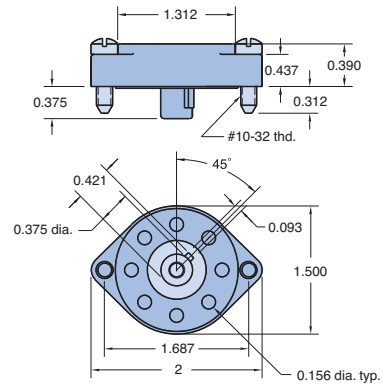

R-821



Volume Chamber

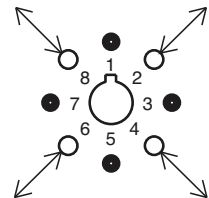

Description:

Volume chamber provided in standard, plug-in Clippard Minimatic® module body, using standardized octoport. May be used for providing time delay in pneumatic circuits. This model has 1.2 cubic inch volume chamber.

R-901



Sequence Valve

Features:

- Indicator shows valve position
- Micro gap construction - snap action and no blow by
- Balanced design allows speed control at exhausts

Performance:

Flow: 9 scfm @ 100 psig; 255 l/min @ 6.9 bars

Pilot Pressure Minimum: 40 psig; 2.8 bars

Temperature: 32 to 180°F

Working Pressure: 0 to 150 psig; 0 to 10.3 bars

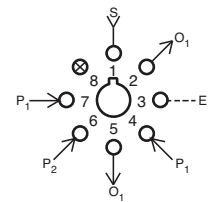
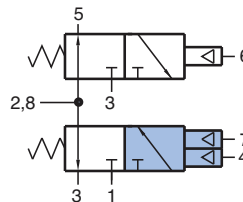

Description:

R-901 is a dual element combination consisting of a 3-way Normally-closed, spring return air piloted valve and a 3-way Normally-open, spring return, air piloted valve. One of the outputs of the N.C. valve is the input to the N.O. valve. A valve position indicator is provided for the N.C. valve. The R-901 is intended for use in sequential stepping control circuits.

R-932



Sequence Valve

Features:

- Indicator shows valve in shaded position
- Micro gap construction - snap action and no blow by

Performance:

Flow: 9 scfm @ 100 psig; 255 l/min @ 6.9 bars
Pilot Pressure Minimum: 20 psig; 1.4 bars
Temperature: 32 to 180°F
Working Pressure: 0 to 150 psig; 0 to 10.3 bars

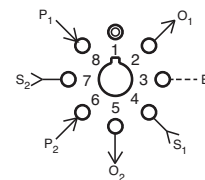
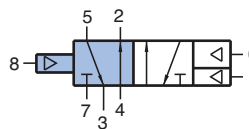

Uses:

The R-932 Sequence Control Module is a compact, efficient component for creating a sequential system for control of a multi-step operation. It has many uses throughout industry.

Description:

R-932 is a 4-way, 5 ported, double piloted, two position valve designed for sequence control application. Availability of two supply and two output ports enables the module to perform the sequential function. One output controls the operation assigned to that step in the cycle. The other output maintains the next step in a hold mode until ready for release. Likewise, the R-932 uses differential pilots. This enables the signal at port 6 to cancel out the force of the opposite pilot at port 8. Shifting of the valve is not possible until the signal at port 6 is removed. When a step is completed, a limit feedback signal actuates the next step. At the end of the sequence the last step resets all the sequence valves, resetting the operation for the next cycle. For each step in the cycle, a separated R-932 module must be used.

R-934



Sequence Valve

Features:

- Indicator shows valve in shaded position
- Micro gap construction - snap action and no blow by

Performance:

Flow: 9 scfm @ 100 psig; 255 l/min @ 6.9 bars
Pilot Pressure Minimum: 20 psig; 1.4 bars
Temperature: 32 to 180°F
Working Pressure: 0 to 150 psig; 0 to 10.3 bars

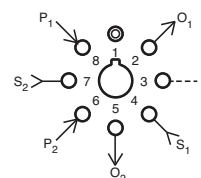
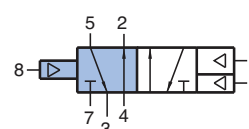

Description:

The R-934 sequence valve is the same as the R-932 sequence valve with the exception of ports 1 and 6. The R-934 port 6 pilot is the same size as the port 8 pilot. This provides a built in safety that if a limit valve is held actuated, the reset signal at port 6 will not reset the sequence, therefore stopping the system with the indicator being in the down position for trouble shooting. The R-934 sequence valve can only be used on the steps that do not have the input signal held Normally-Open.



MODULAR ELECTRONIC SEQUENCING VALVES

R-982-□

Electronic Piloted Sequence Valve



Features:

- Extremely low power consumption
- Patented micro gap valving for quick action, no blow by
- Standard octoport plug-in design
- Provides interface between electronics and pneumatics

Performance:

Working Range: 20 -105 psig;
Flow: 9 scfm @ 100 psig; 255 l/min @ 6.9 bars
Pilot Pressure Minimum: 20 psig; 1.4 bars
Temperature: 32 to 180°F
Power Consumption: 0.65

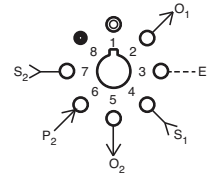
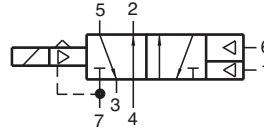

Voltage.....	R-982-6	6 VDC
	R-982-12	12 VDC
	R-982-24	24 VDC

Duty: Continuous duty at 150% of rated voltage

Description:

R-982 electronic sequence valve is essentially a hybrid valve consisting of the R-932 valve and the Clippard model ET-3 electronic/pneumatic valve. The ET-3 responds to low current, low voltage signals and pneumatically actuates the R-932 sequence valve to which it is attached.

R-984-□

Electronic Piloted Sequence Valve



Features:

- Extremely low power consumption
- Micro gap construction - snap action and no blow by
- Standard octoport plug-in design
- Provides interface between electronics and pneumatics

Performance:

Working Range: 20-105 psig; 1.4-7.2 bars
Flow: 9 scfm @ 100 psig; 255 l/min @ 6.9 bars
Pilot Pressure Minimum: 20 psig; 1.4 bars
Temperature: 32 to 180°F
Power Consumption: 0.65

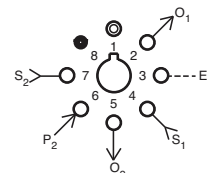
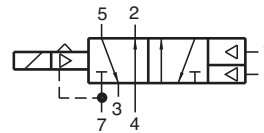

Voltage.....	R-984-6	6 VDC
	R-984-12	12 VDC
	R-984-24	24 VDC

Duty: Continuous duty at 150% of rated voltage

Description:

The R-984 electronic sequence valve is essentially a hybrid valve consisting of the R-934 valve and the Clippard model ET-3 electronic/pneumatic valve. The ET-3 responds to low current, low voltage signals and pneumatically actuates the R-934 sequence valve to which it is attached.

APPLICATION

ap-pli-ca-tion \ap-lə-ˈkā-shən\ n 1 : the act of applying 2 : assiduous attention 3 : REQUEST; also : a form used in making a request 4 : something placed or spread on a surface 5 : capacity for use

The following circuits show a few of the many useful ways to use Clippard Minimatic® modular components in practical pneumatic circuitry. The drawings presented here are combinations of ANSI and Octoport piping diagrams. For more information and application assistance contact your nearest Clippard distributor.

Initial Approach to Designing a Pneumatic Control

1. Have a clear verbal understanding of the sequence of operations desired.
2. Put down on paper:
 - A. Manual controls necessary or required and what their function is to be.
 - B. Other available input signals from:
 1. Limit valves
 2. Sensors
 3. Other controls or control media
 - C. All output devices (cylinders, piloted valves, electrical motors, etc.) that are to be controlled.
3. Determine all mechanical interlocks that exist.
4. Determine all the safety interlocks that must exist.
5. Work out the logic portion of the control utilizing the inputs and outputs at hand. Employ the functional circuit concept. Remember even the most complicated control circuits are composites of smaller functional circuits.
6. Check the final circuit for proper actuation during:
 - A. Start up
 - B. Shut down
 - C. Loss of air
 - D. Panic stops in the middle of cycle
 - E. Restarts in the middle of the cycle
 - F. Control during other events that are likely to occur

Cycling Without Limit Valves

This circuit enables a double acting cylinder to reciprocate without the use of limit valves and to control its speed in each direction. As C-1 retracts, it creates a back-pressure behind the piston which is further increased by restricting the exhaust air at port 3, V-2, to slow the return of the cylinder rod. This back pressure holds the pilot closed on V-3. When C-1 has fully returned, the back pressure diminishes. When there is insufficient pressure to hold the pilot down on V-3, the spring shifts the valve, which sends pressure to the right hand pilot, port 4, of V-2. This causes V-2 to shift, which starts C-1 to extend and pilots V-3 exhausting the pressure on the right hand pilot of V-2.

As C-1 extends, an identical sequence occurs between V-1 and V-2, causing the 4-way valve to shift when C-1 has fully extended.

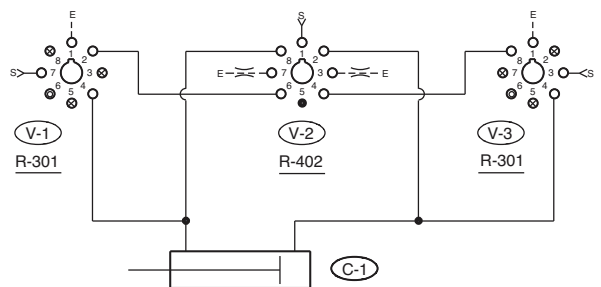
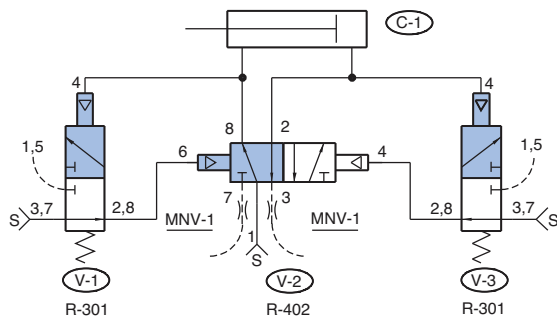

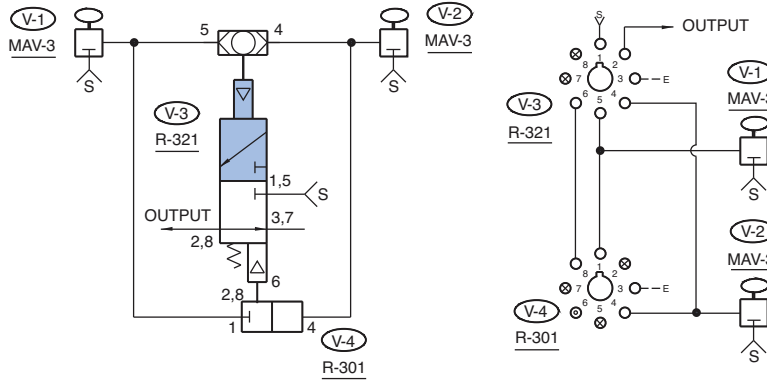

Exclusive "OR" Circuit

The exclusive "OR" circuit operates as follows: When V-1 is depressed, the signal goes to both V-3 and V-4. The signal at V-4 is blocked. The signal at V-3 actuates the valve and provides an output signal. If V-2 is actuated independently, the same sequence occurs.

If both V-1 and V-2 are actuated, the output at V-4 energizes the bottom pilot which, together with the spring, overrides the opposite pilot of V-3, nullifying both signals, V-3 thus remains off.

Circuit Function

INPUTS	V-1	off	off	on	on
	V-2	off	on	off	on
OUTPUT	V-3	off	on	on	off

Motion Sensing Circuit

V-1 is actuated by rotary or linear cam. Pressure from V-1 goes to a pulse valve (V-2) where it is converted to a uniform pulse each time V-1 is actuated. Each pulse goes through the check valve of V-3 and holds the pilot down on the valve. C-1 is retracted. The pressure holding the pilot of V-3 is constantly trying to exhaust through the adjustable needle valve V-3 and out to atmosphere through the exhaust port of the pulse valve V-2.

When motion stops (or falls below a pre-determined C.P.M.) the pressure on the pilot of V-3 exhausts and the spring shifts the valve, which causes C-1 to extend. The R-341 is shown as Normally-Closed. It can also be used as Normally-Open, a selector, or a diverter.

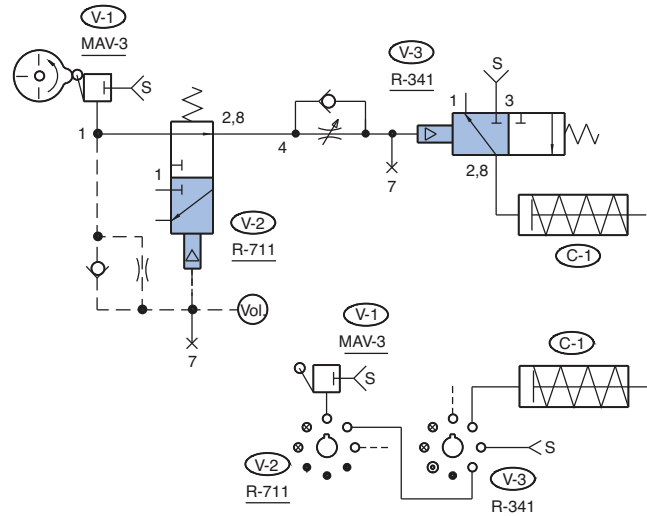

Signal Release Pulse Circuit

This circuit gives a single pulse output of adjustable duration when its input signal is released (exhausted). Upon actuation of the input 3-way valve, V-1, air is supplied to both valve pilots simultaneously so the valve, V-2, remains in the closed position. Upon release of the input signal the pilot on the spring side of the valve is exhausted immediately. This allows the "trapped" air in the volume tank to actuate the valve causing the output to come on. The valve remains actuated until the trapped air bleeds off through the adjustable needle valve.

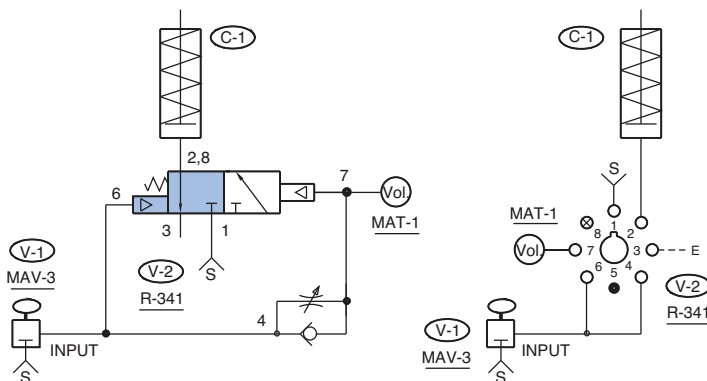

Use of Shuttle Valves

The R-603 is a three input shuttle valve sometimes called a three input "OR". Actuation of V-1 or V-2 or V-3 will give an output at port 6, of V-4, and extend C-1.

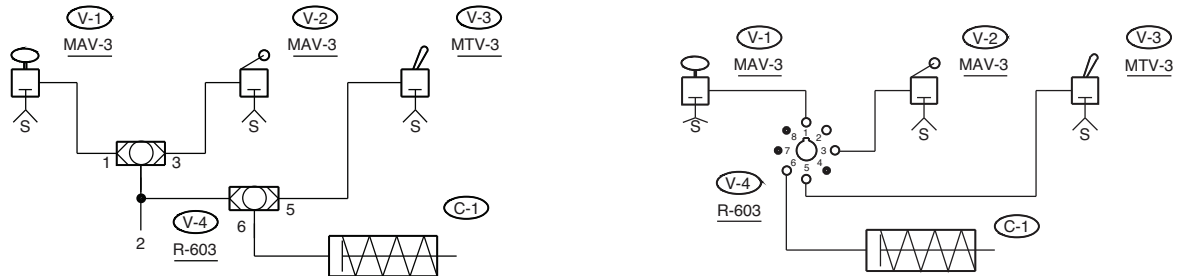

Adjustable 4-Way Pulse

When V-1 is actuated a signal pilots port 4, V-3, extending C-1. The signal is also going to the auxiliary pilot but is delayed by the flow control V-2. When pressure builds up on the pilot, port 6, V-3, it, together with the spring, overcomes the opposite pilot and shifts the valve. C-1 then retracts. V-3 will not cycle again until V-1 is released.

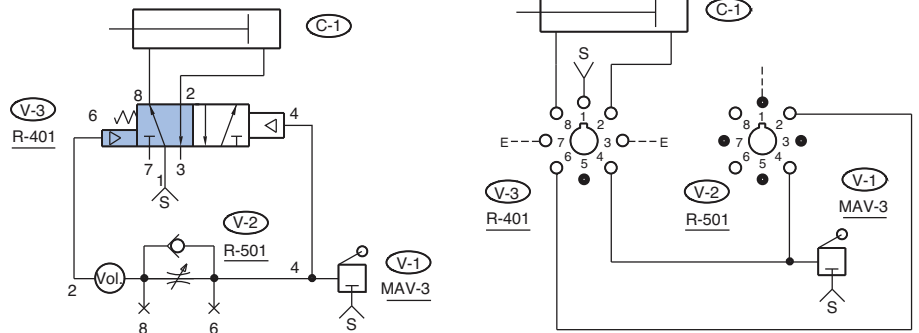

Two-Hand, No-Tie-Down

This circuit provides an output signal to power or pilot a piece of machinery when two push buttons are manually pressed simultaneously. Neither button can be tied down. The output will cease if either button is released. See CM-023 in the Pneumatic Circuit Board section for more details.

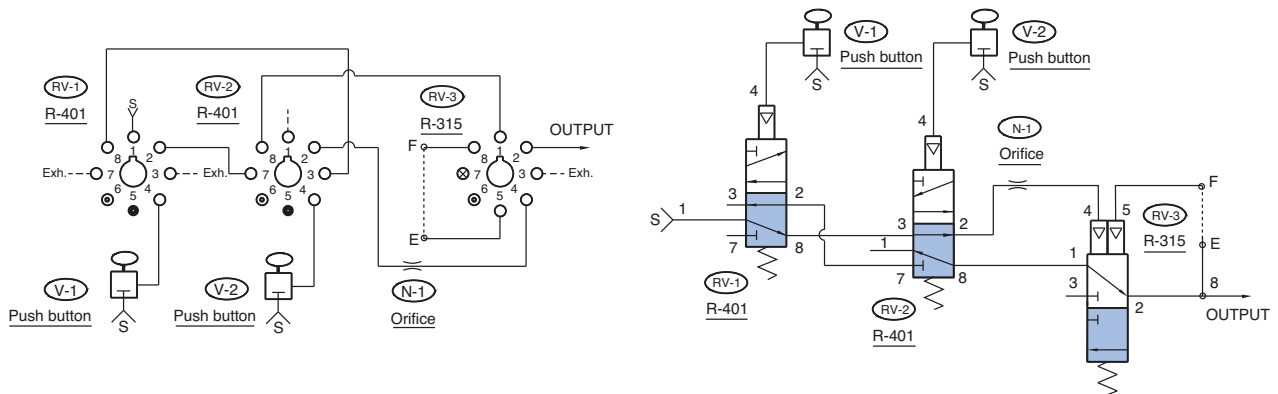

Pilot Signal Priority Lockout

Application of a pilot signal from either push button will pneumatically lock out the output of the other push button to eliminate the possibility of a dual output.

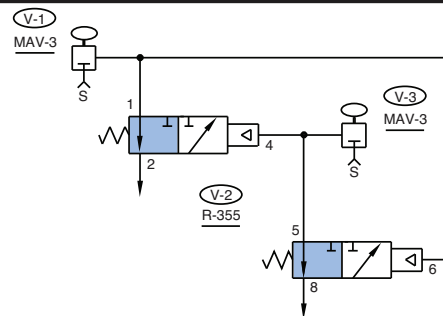

932 Sequence Control Circuit

A typical sequence circuit is shown below. It includes five R-932 sequence modules, two R-402 4-way modular valves, (power valves) and two cylinders, each equipped with two limit valves. This typical circuit is designed for Cylinder A to extend and return, then Cylinder B to extend and return.

In inactive mode, LVA- and LVB- are held passing, supplying pressure to port 8 of both SM3 and SM5. The valves will not actuate because there is air already to port 6 which connects to a larger pilot.

When the start button is actuated, pilot pressure is applied to SM1, shifting the valve which pressurizes port 4 of power valve "A" (PVA) pressure at its port 4. This shifts PVA, extending the cylinder. When SM1 shifts, it also removes pressure from SM2 at port 6 preparing it for step 2.

Extension of cylinder A actuated LVA+. This shifts SM2, providing pressure to port 6 of PVA which shifts and powers the retraction of Cylinder A. The shifting of SM2 also removes supply from port 4 of step 1 allowing the cylinder retraction, and removes supply from port 6 of SM3, preparing it for step 3.

As a result, when LVA- attains passing position this time, there is no pressure on the larger pilot of SM3. It shifts, providing supply to port 4 of PVB. The power module shifts, with resultant flow extending Cylinder B. The sequence cycle continues through retraction and stops unless the start button remains actuated. Continuous cycling can be accomplished by using a toggle or selector valve for the start button.

Retraction of cylinder B actuates LVB- causing a chain reaction for resetting the sequence valves for the next cycle.

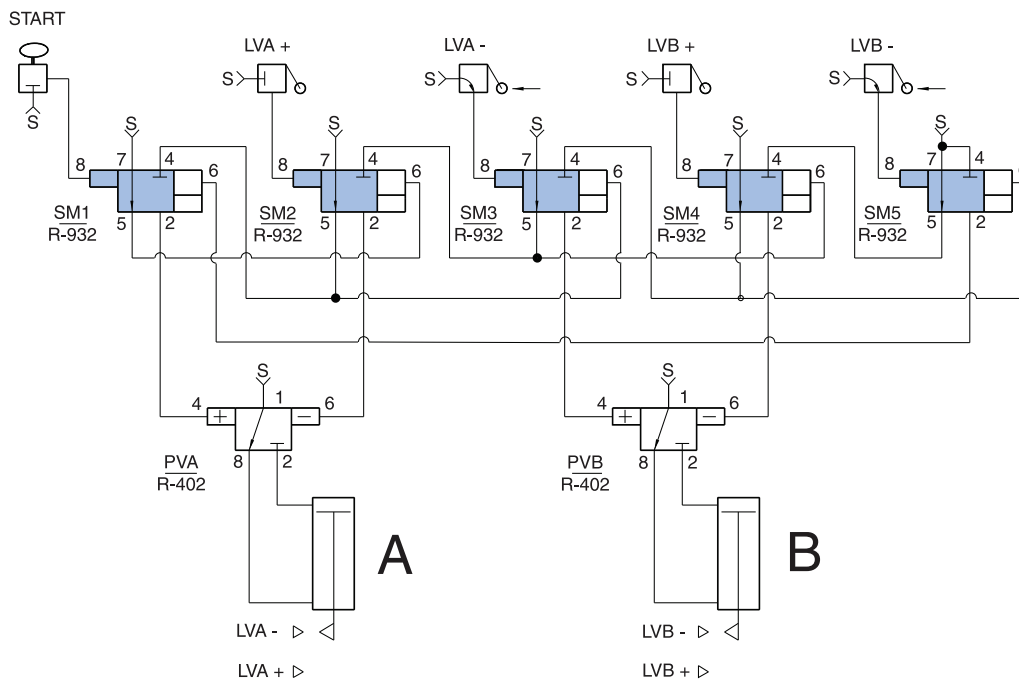

NOTE: The SEQUENCE IS FOLLOWED by the indicator in the valve. The last indicator down is the last step actuated. This is helpful when trouble shooting a circuit.

The circuit described above is an example of a typical sequence circuit. Most applications will require additional functions. Therefore, the number of sequence valves will increase, but the procedure for connections and applications of the R-932 remain.

It is important to remember the input signals can come from other types of input devices such as: proximity sensors, gap sensors, back pressure sensors, pressure sensors, limit valves, electronic Hall Effect sensing, liquid level sensing, part sensing, etc.

By using modular components found in this catalog, additional functions such as "Delay IN (R-333) "AND" (R-301) can be added to the sequence circuits.

The sequence circuit can also be used with larger air power valves or air piloted hydraulic valves.

Bleed Piloted 4-Way Valve

Pressure in line 4 pilots valve V2 so that the cylinder is retracted on the valve V-2 and C-1 retracted. When V-1 is actuated, the pressure is exhausted from 4 faster than the restricted supply at 5 can make it up. The spring then shifts the valve and C-1 extends.

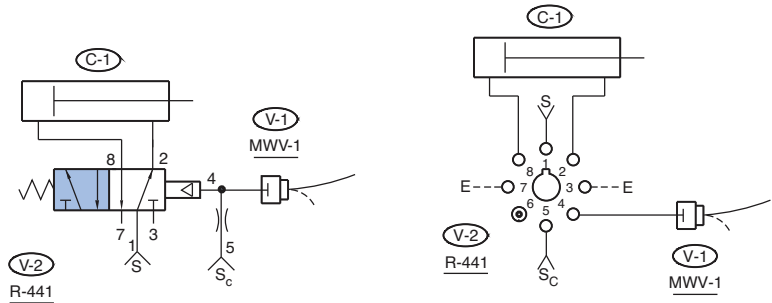

Unique Open-Close Pulse Circuit

This pulse circuit can be adapted to a wide variety of uses. It consists of an MAV-3 3-way valve and two standard R-341 modular valves, and is being used to open and close a collet vice on a milling fixture. Circuit operation: when V-1 is depressed, V-2 gives an output pulse at "A". The length of the pulse is predetermined by the needle valve adjustment on V-2.

When V-1 is released, a pulse occurs at "B".

This pulse is also determined by the length of the needle valve on V-3. Thus both pulses are independently adjustable. Note that the R-341 allows supply to be segregated from the pilot signal which allows for different pressures or gases to be controlled.

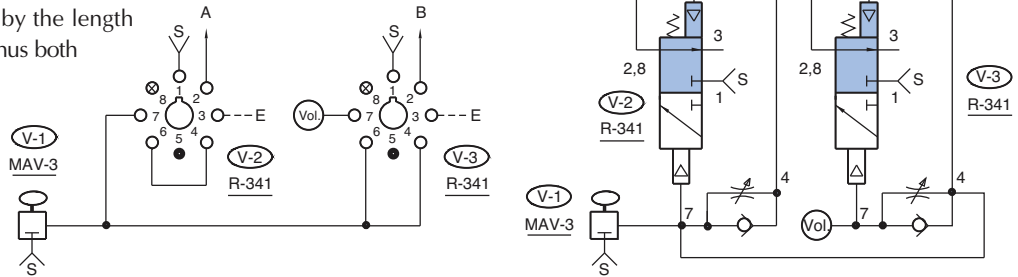

"Latch" Circuit

Actuation of V-1 pilots V-3 and extends C-1. The same pressure that extends C-1 also passes through V-2 and holds the twin pilot down locking C-1 in the out position even though V-1 is released. When V-2 is actuated, breaking the line between port 2 & 5, V-3, and exhausting the pilot, the spring will shift the valve V-3, causing C-1 to retract.

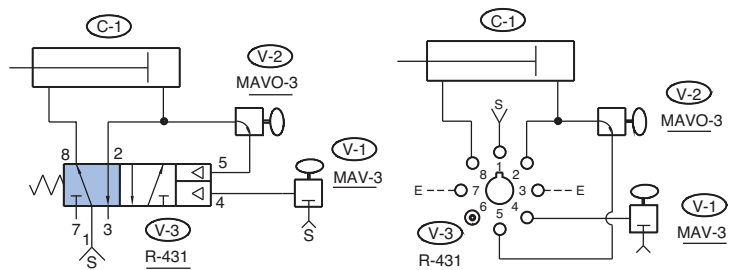

"Active Or" Circuit

Actuation of any one or all of the input signal valves, V-1, V-2, V-3, V-4, will cause an active output (an output from a separate air supply source).

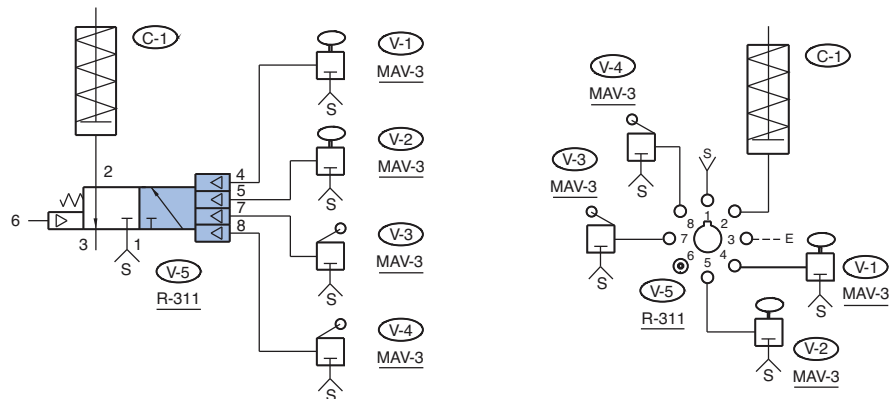

Assembly Jig Control

This circuit is used with an assembly jig that draws a vacuum on a part inserted into it. When the operator has finished working on the part, a spring return knock out cylinder pushes the part out of the jig. Depressing V-1 pilots V-3 which draws a vacuum on the jig. Releasing V-1 allows the spring in V-3 to shift the valve, connecting air to V-2, an adjustable pulse valve, which gives a controlled pulse of air to the knock out cylinder in the jig.

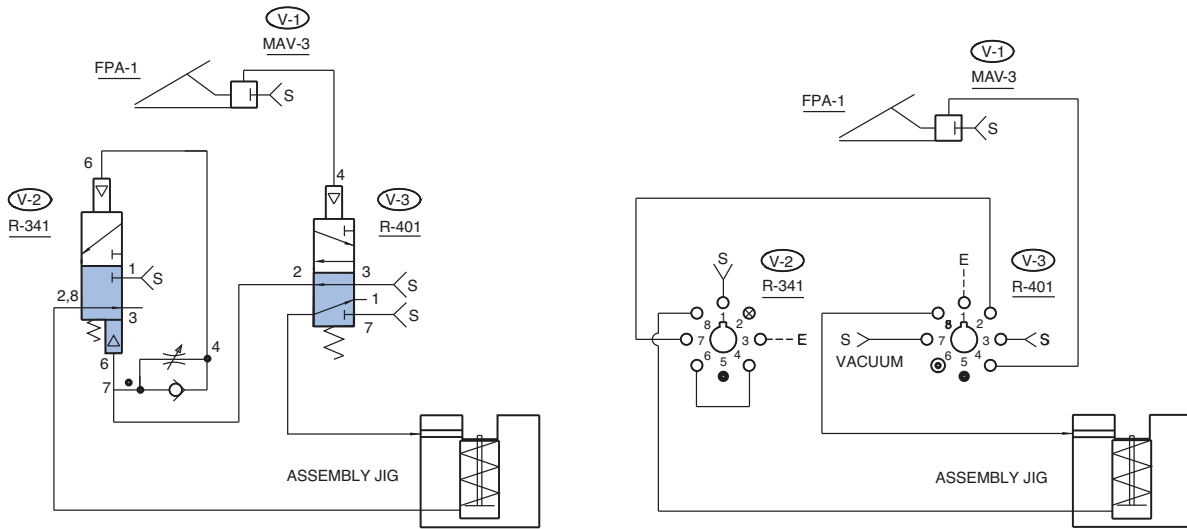

Piloted 4-Way Valve

When V-1 is actuated, pressure forces the pilot to overcome the spring and shift the valve V-2, causing C-1 to retract. Releasing V-1 exhausts the pressure on the pilot and allows the spring to shift the valve extending C-1.

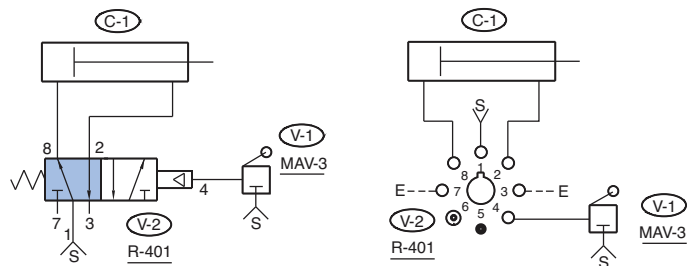

Automatic Cycler

Turning on the toggle switch V-1 sends a signal through V-2 and to the flow control of V-3 where it is delayed before piloting the 3-way (Normally-Closed) valve V-3, which extends C-1. The output of V-3 also goes to the flow control of V-2 where it is delayed before piloting the 3-way (Normally-Open) valve V-2.

When V-2 shifts, it shuts off the original signal from V-1 and exhausts the pressure that has piloted V-3, allowing the spring to shift the valve. This causes C-1 to retract and also exhausts the pressure that has piloted V-2, allowing the spring to shift the valve. This allows the signal from V-1 to start the cycle over again. The adjustment on V-3 controls the "IN" duration, and the adjustment on V-2 controls the "OUT" duration at C-1.

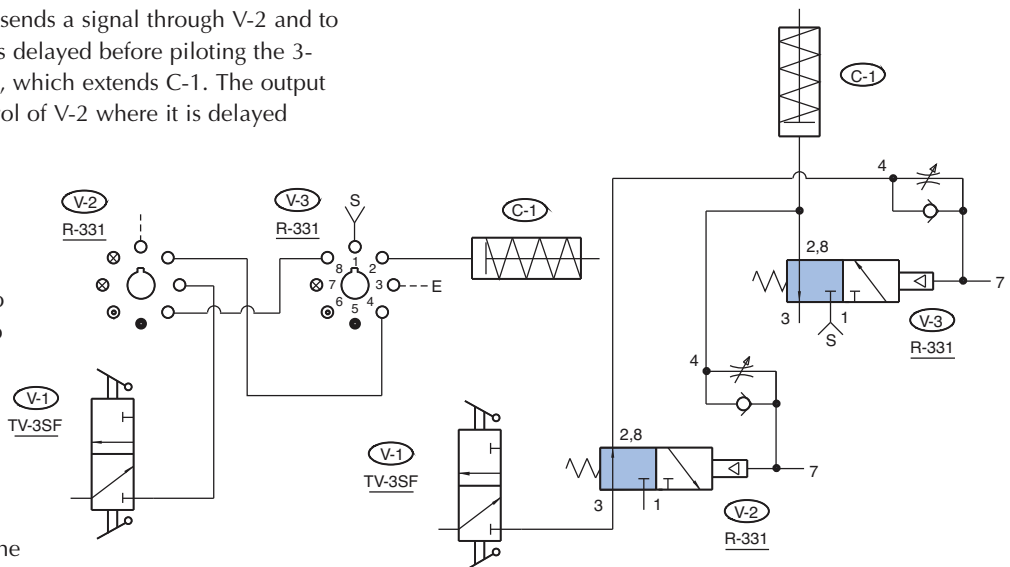

Adjustable Pulse Valve

The R-341 delay valve may be used to provide an adjustable pulse (N.C.) or adjustable off (N.O.) signal. When an input occurs at port 7 it immediately pilots the valve and gives a signal at ports 2 & 8, which extends C-1. The same input is also being delayed through the flow control (between 7 & 4) until enough pressure builds up to actuate the auxiliary pilot which, together with the spring, overcomes the opposite pilot and shifts the valve shutting off the output. C-1 then retracts. The input must be removed before the valve will reset and cycle again. Since the input is separate from the supply and output valving, separate pressures or fluids can be used in the valve. Pulse times can range from 25 ms to 5 seconds. The second drawing shows the R-341 piped Normally-Open. The same sequence applies as above, only the valve is going off for a period instead of on.

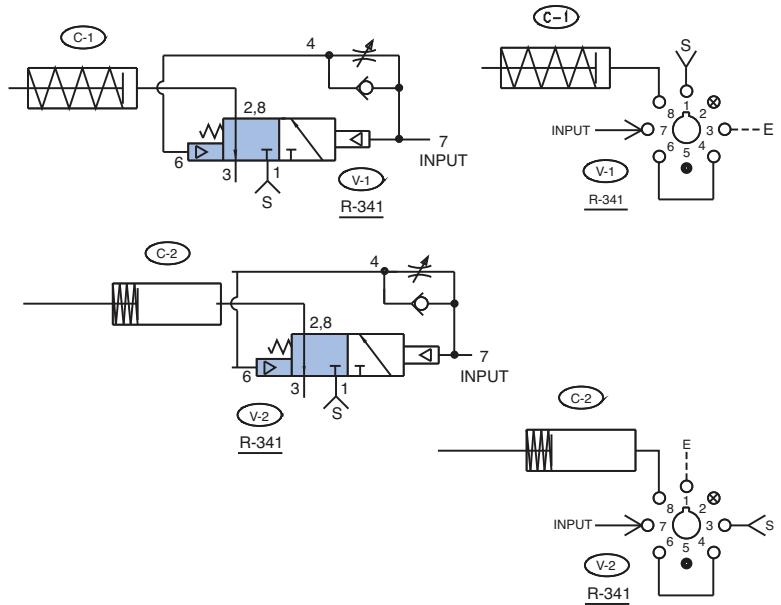

Set-Reset Circuits

Shown are three examples of set-reset circuits, also called "latch" circuits. There are many ways to set or reset a valve or group valves. These examples make use of the unique auxiliary pilots available on many of the modular valves.

A set occurs when a valve is actuated and part of the output is used to hold the valve in the actuated position, even though the original pilot signal may be gone.

Generally a circuit is reset by interrupting the "set" pilot line or air supply to the valve when an opposite pilot is present to shift the valve. The modular auxiliary pilot, in combination with the valve spring, will overcome any or all opposite pilot(s) to reset the circuit.

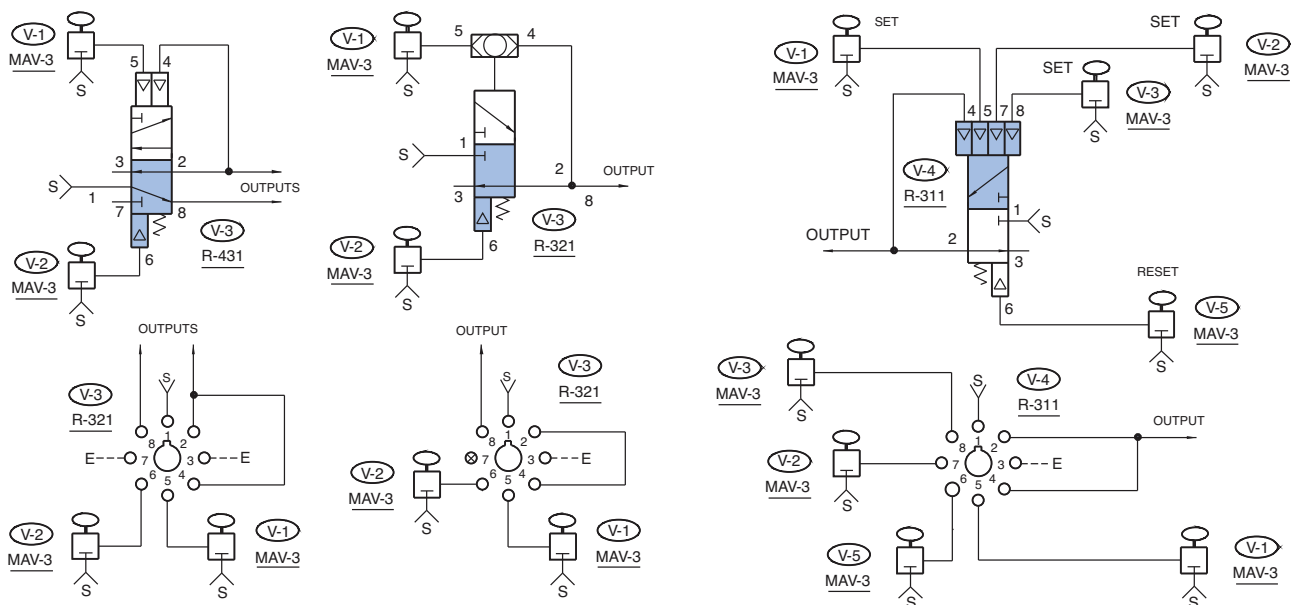

Six Ported 4-Way

This circuit controls two double acting cylinders with a single 4-way (6 ported) valve. When V-1 has been depressed, actuation of V-3 will extend or retract C-1. When V-2 has been depressed, actuation of V-3 will extend or retract C-2.

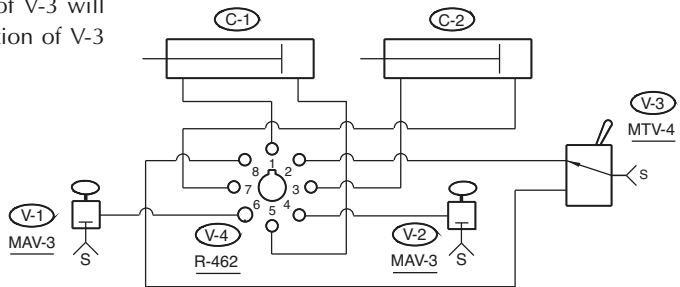
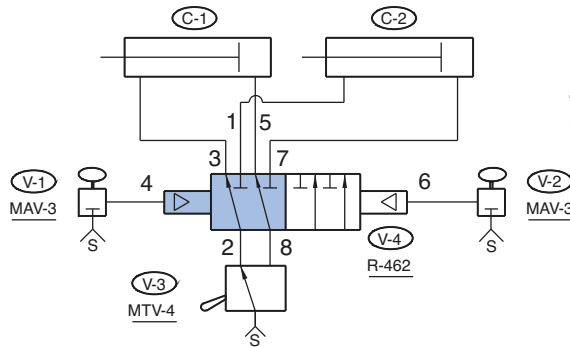

Three Input "And"

The R-353 valve will give an output at C-1 only when V-1, V-2, and V-3 are depressed. Remove any of the three inputs and the output ceases.

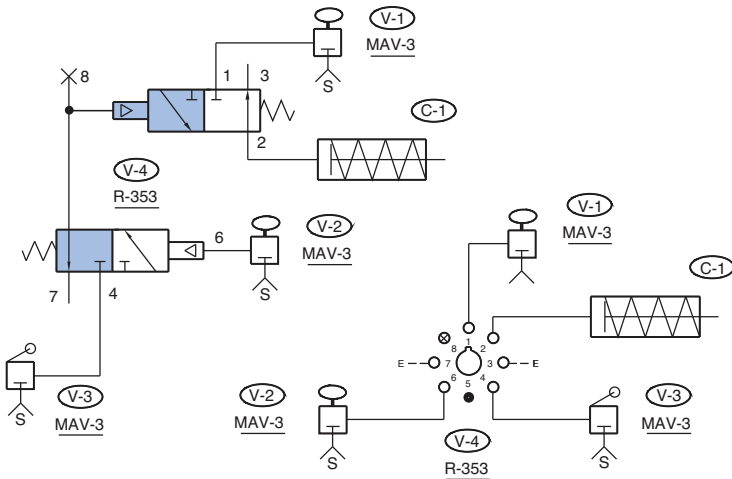

Exhaust Piloted 3-Way Valve

Pressure in line 7 holds pilot down on the valve V-2 which has no output signal. When V-1 is actuated, pressure is exhausted from line 7 faster than the adjusted supply can make it up. The spring then shifts the valve giving an output at ports 2 & 8. (Port 8 is shown as blocked.)

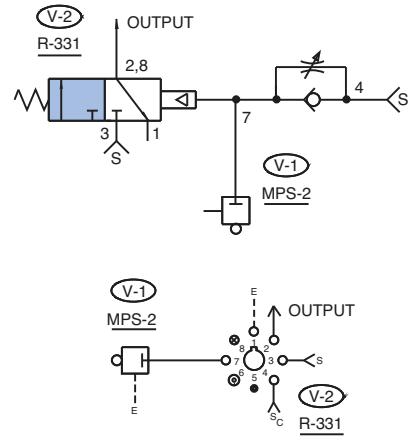

Piloting From Two Inputs

Actuating of either V-1 or V-2 will pilot V-3 causing C-1 to extend. The R-321 is shown Normally-Closed. It may also be used Normally-Open, as a selector, or as a diverter. An R-315 provides the same function by having two separate pilots.

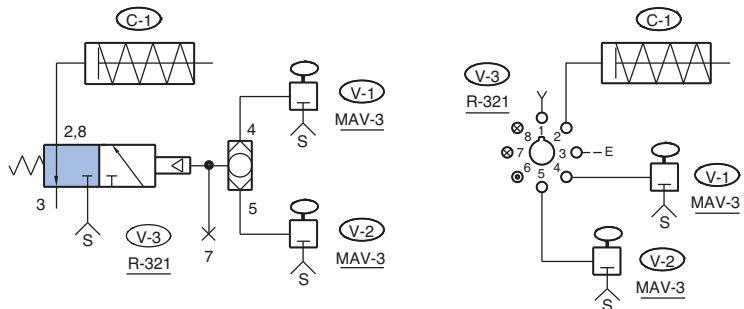

Clippard Instrument Laboratory has pioneered the miniature pneumatic industry. We have an expansive line of components that are used in thousands of applications across many markets. It is this experience and knowledge of our own products that is now available to our customers when collaborating with Clippard to develop the right solution. Our production, engineering, and sales staff will come together with your organization to design, build, QC, and ship your pneumatic assembly when you need it.

Our goal is to optimize a systems design, to increase performance, reduce cost, and allow our customers to concentrate on their core competencies.



Clippard offers the following services:

- Pneumatic Assemblies
- Special Manifold Designs
- Manifold Assemblies
- Pneumatic Circuit Design
- Control Boxes
- Fitting & Tubing Harnesses
- Component Kitting
- Specialized Testing
- KanBan Services



Adding Value is Our Business!

Advantages

- 100% tested sub-assemblies
- Less component stock/inventory
- Fewer vendors and purchase orders
- Requires less manufacturing time
- Increase production efficiency
- Specialized support
- Overall cost reduction
- Taking advantage of Clippard's expertise



Clippard's Integrated Solutions team designed a simple, straight-forward approach for piloting process valves. This assembly greatly simplifies the installation and ease-of-use for the OEM design engineer.

Clippard has a unique advantage by providing custom products and value-added assemblies based on the most successful miniature pneumatic line in the world.