

Electronic Vacuum Regulator

QKL-B3V



The electronic vacuum regulator is a closed loop design, consisting of 2 solenoid valves, one pressure transducer and an electronic board that performs PID closed loop control. According to the input electronic signal, one valve opens up the vacuum inlet, and the other valve acts as vacuum breaker. Whilst increasing the vacuum level, the inlet valve acts upon the internal piston and allows air to be withdrawn. The internal pressure transducer senses the vacuum level and provides feedback to the electronic board which in turn controls the action of two valves until the target vacuum level is reached.

KaoLu's vacuum pressure regulator receives input signal of 0-10V or 4-20mA.

Specifications

Type	QKL-B3V		
*Output Range	0~ -101 kpa	Repeatability	±0.3% F.S.
Input Signal	0-10V / 4-20mA	Hysteresis	±0.25% F.S.
Monitor Output	0-10V / 4-20mA	Linearity	±0.3% F.S.
Power Supply	DC24V (≤4W)	Accuracy	±0.3% F.S.
Response	0.8S	Medium	Vacuum
Temp. Range(Operating)	0-70°C (32-158 °F)	Flow Rate	250~600L/min
Port Size	G1/4"	Electrical Connection	M12 Connector (2m)
Life Cycle	Over 1 Billion Times	Ingress Protection	IP65
Weight	550 g	Manifold Material	Aluminum

*A positive pressure of at least 0.5 bar must be applied to the P port to achieve 0 Kpa. Without it the operating pressure range is -26kPa to -101 Kpa.

Ordering Code

QKL - □ - □ - □ - □ - □

Type

B3V	Internal Feedback	G 1/4"
-----	-------------------	--------

Monitor Output

C	0 - 10 V
A	4 - 20 mA

Display Unit

S	Kpa
U	mmHg

Input Signal

*E	0 - 10 V
A	4 - 20 mA

Mounting Bracket

M	M type
L	L type

*For Command Signal type 0-10V, the minimum driving current is 3mA.



Kao Lu Enterprises Co., Ltd. TEL:886-4-24874219 · 24860626
Genn Dih Enterprises Co., Ltd. FAX:886-4-24864269 · 24862824
Web:www.genndih.com E-mail:genndih@ms43.hinet.net
No. 17, Lane 822, Sec. 2, Zhongxing Rd., Dail Dist., Taichung City 41244, Taiwan(R.O.C)

Electronic Vacuum Regulator

QKL-B3V



Overall Dimension

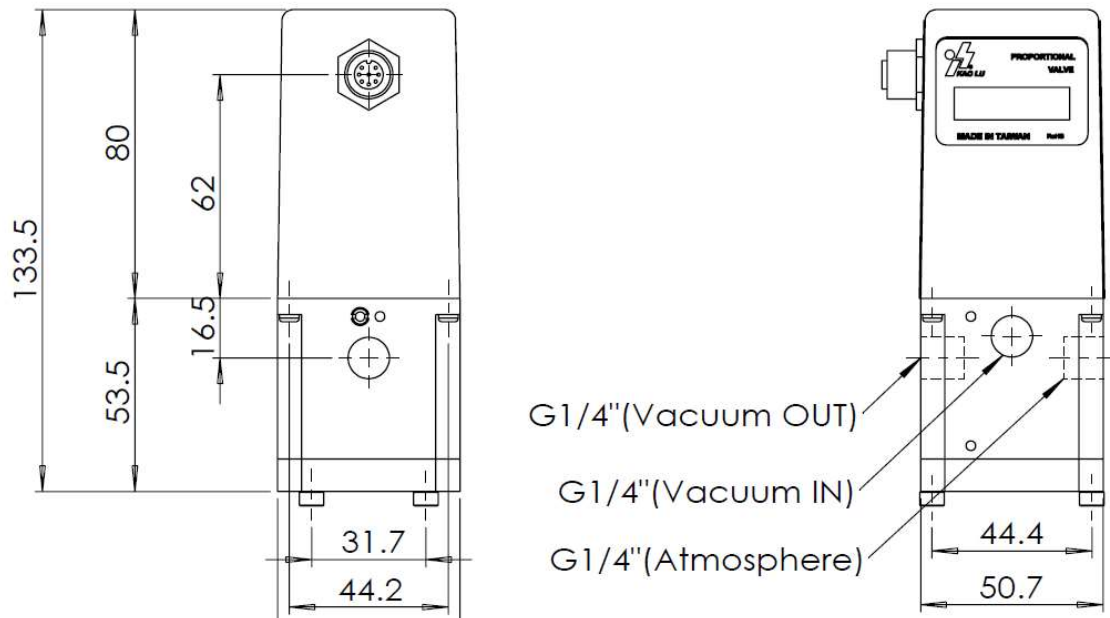

Bracket L Type

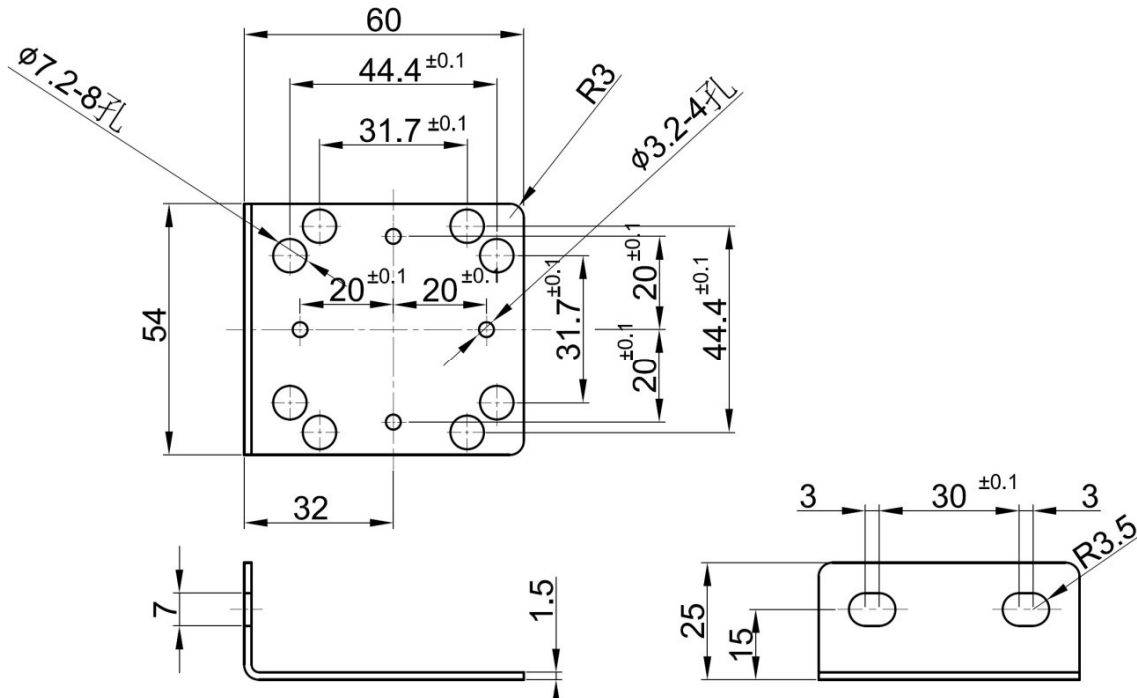

Kao Lu Enterprises Co., Ltd. TEL:886-4-24874219 · 24860626
Genn Dih Enterprises Co., Ltd. FAX:886-4-24864269 · 24862824
Web:www.genndih.com E-mail:genndih@ms43.hinet.net
No. 17, Lane 822, Sec. 2, Zhongxing Rd., Dail Dist, Taichung City 41244, Taiwan(R.O.C)

Electronic Vacuum Regulator

QKL-B3V



Bracket M Type

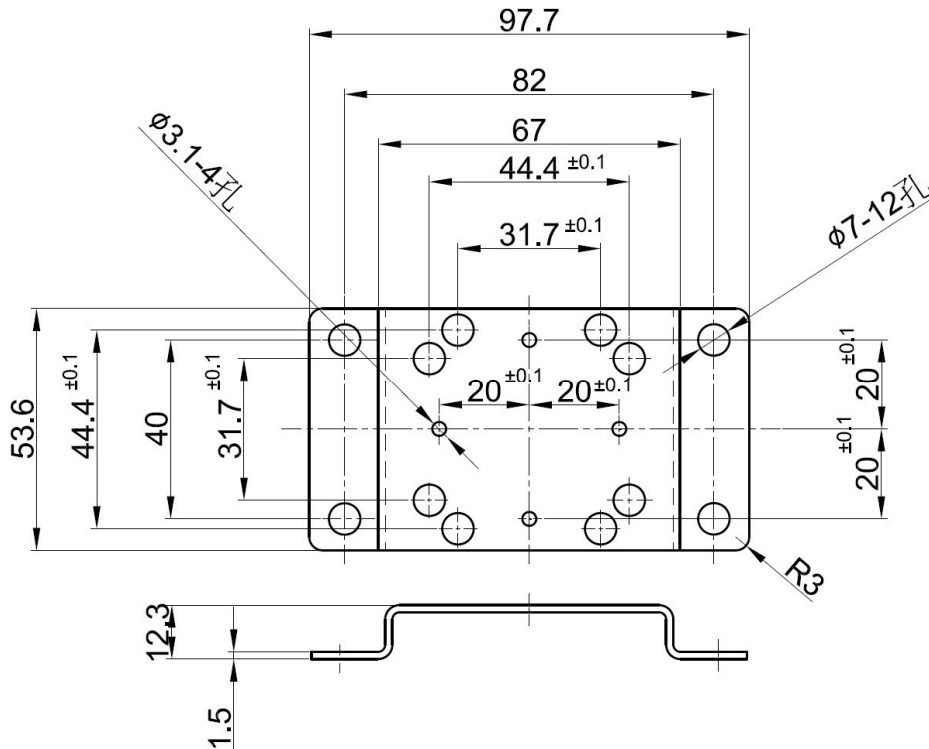

Wiring Description

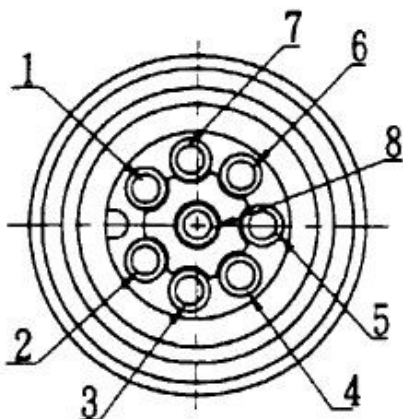

※The wiring diagram shows from top view.

No.	Color	Function
1	Blue	24V DC Power (-)
		Command (-)
		Output monitor (-)
2	Brown	24V DC Power (+)
3	Black	Monitor output (+)
4	White	0-5 V Command (+)
		0-10 V Command (+)
		4-20 mA Command (+)



Warning: Do not rotate the connection socket when connected,
to avoid damage to the internal sensor.



Kao Lu Enterprises Co., Ltd. TEL:886-4-24874219 · 24860626
Genn Dih Enterprises Co., Ltd. FAX:886-4-24864269 · 24862824
 Web:www.genndih.com E-mail:genndih@ms43.hinet.net
 No. 17, Lane 822, Sec. 2, Zhongxing Rd., Dail Dist., Taichung City 41244, Taiwan(R.O.C)