

AP LINE

AP



Raccordi Automatici "Mix"
"Mix" Push-in Fittings
Raccords Instantanés, "Mix"
"Mix" Steckverschraubungen



Raccordi Automatici costituiti da un "MIX" di materiali, ottone/tecnopolimero, che permette di avere una soluzione più economica del raccordo completamente in ottone, senza alcuna penalizzazione a livello di prestazioni.



Push in fittings made of a materials "MIX", brass and Technopolymer. This line offers a more competitive priced fitting than the whole brass version, without affecting the fitting performance.



Raccords instantanés fabriqués en un "MIX" de matériaux, laiton et technopolymere, qui offrent une solution plus compétitive de la série en métal sans aucune pénalisation à niveau de performance.



Steckverschraubungen aus einem "MIX" von Materialien, Messing und Technopolymer, die eine wettbewerbsfähigere Lösung zu der Metallausführung bietet, ohne die Verschraubungsleistungen zu vermindern.

1	2 - 3	4	5	6
Corpo Body Corps Körper	Anello Estrattore e di Ritegno Release and Holding Ring Poussoir et Bague de retenue Lösering und Haltering	Pinza aggraffaggio Gripping collet Pince Spannzange	Anello portapinza Protection Ring Bague protection Schutzring	Guarnizioni Seals Joint d'étanchéité Dichtung
Ottone UNI EN 12164 CW614N - UNI EN 12165 CW617N Nichelato Brass UNI EN 12164 CW614N - UNI EN 12165 CW617N Nickel Plated Laiton UNI EN 12164 CW614N - UNI EN 12165 CW617N Nickelé Messing UNI EN 12164 CW614N - UNI EN 12165 CW617N vernickelt	Resina Acetalica (POM) Acetal Resin (POM) Résine acétal (POM) Azetalharz (POM)	Acciaio INOX AISI 301 Stainless steel AISI 301 Acier Inox AISI 301 Edelstahl AISI 301	Resina Acetalica (POM) Acetal Resin (POM) Résine acétal (POM) Azetalharz (POM)	NBR NBR NBR NBR

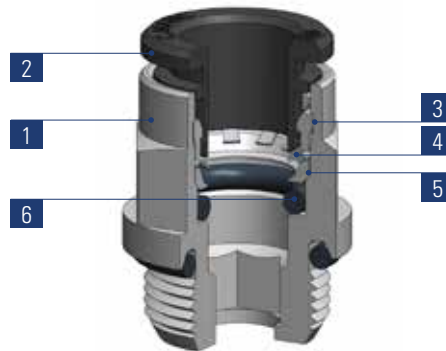
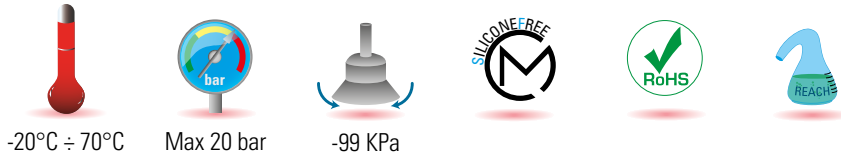

	M5x0,8	M12x1,5	G1/8	G1/4	G3/8	G1/2	R1/8	R1/4	R3/8	R1/2
4	●		●				●			
6	●	●	●	●			●	●		
8			●	●	●		●	●	●	
10				●	●	●		●	●	●
12				●	●	●		●	●	●

SPECIFICHE TECNICHE

Tubi di collegamento consigliati:
PA11, PA12, PA6, Polietilene PE,
Poliuretano PU (98 Shore A).
Tolleranze accettabili sui tubi:
+/- 0,07 mm fino a Ø 10 mm
+/- 0,1 mm da Ø 12 a Ø 14 mm.

Campi di applicazione:
Impianti pneumatici.

DATA SHEET

Recommended tubings:
PA11, PA12, PA6, Polyethylene PE,
Polyurethane PU (98 Shore A).
Acceptable Tolerances on the tubings:
+/- 0,07 mm up to Ø 10 mm
+/- 0,1 mm from Ø 12 up to Ø 14 mm.

Application fields:
Pneumatic circuits.

EINSEIGNEMENTS TECHNIQUES

Tubes conseillés:
PA11, PA12, PA6, Polyethylene PE,
Polyurethane PU (98 Shore A).
Tolerances sur les tubes:
+/- 0,07 mm jusqu'au Ø 10 mm
+/- 0,1 mm de Ø 12 jusqu'au Ø 14 mm.

Domaines d'application:
Circuits pneumatiques.

TECHNISCHE AUSKÜNFTE

Empfohlene Schläuche:
PA11, PA12, PA6, Polyethylen PE,
Polyurethan PU (98 Shore A).
Schlauchtoleranzen:
+/- 0,07 mm bis Ø 10 mm
+/- 0,1 mm von Ø 12 bis Ø 14 mm.

Anwendungsbereiche:
Pneumatik

Profondità di inserimento del tubo Tubing insertion depth Profondeur d'insertion du tube Schlaucheinstecktiefe

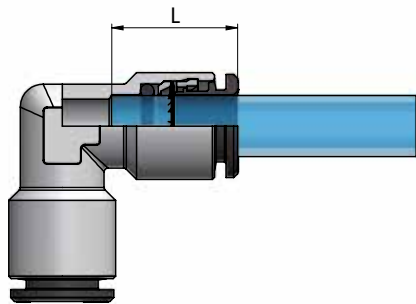

Øe Tubo	L
4	13,4
6	16,4
8	16,5
10	18,7
12	20,1
14	23

ISTRUZIONI DI MONTAGGIO ASSEMBLY INSTRUCTIONS INSTRUCTIONS DE MONTAGE MONTAGEANWEISUNGEN

1. Tagliare il tubo a 90° (servendosi della pinza tagliatubo TCUT) verificando l'assenza di bave interne ed esterne e facendo attenzione che il tubo non si presenti ovalizzato dopo il taglio.
2. Inserire il tubo nel raccordo spingendolo fino in battuta.

1. Cut the tube square (by means of a hose cutter i.e. our TCUT) making sure that no burrs are left and that the tube is not oval.
2. Insert the tube into the fitting until it bottoms.

1. Sectionner le tube à 90° par notre coupe tube TCUT en prenant soin de ne pas créer des bavures et de ne pas ovaliser le tube.
2. Pousser le tube jusqu'au fond du raccord.

1. Schlauch mittels unserer Schlauchschere (TCUT) 90° abschnitten und entgraten.
2. Darauf achten, daß der Schlauch danach nicht oval gequetscht ist und dann ihn bis zum Verschraubungsanschlag einstecken.

Estrazione del tubo

Esercitare una leggera pressione sull'anello estrattore, estraendo contemporaneamente il tubo dal corpo del raccordo.

Tube release

While pressing on the release ring, pull out the tube from the fitting.

Débranchement du tube

Appuyer sur le poussoir en métal et tirer simultanément sur le tube.

Schlauchlösen

Auf den Druckring drücken und gleichzeitig den Schlauch rausziehen.

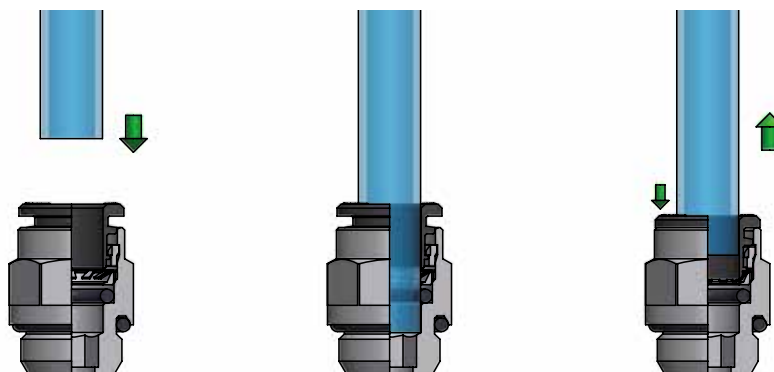

Effettuato il collegamento, assicurarsi che il tubo inserito nel raccordo non sia sottoposto ad alcuna forza di trazione; è necessario inoltre rispettare durante il collegamento del tubo il raggio minimo di curvatura consigliato così come riportato nella sezione tubi di questo catalogo tecnico (vedi pag. 337)

Al fine di evitare lo sgancio involontario del tubo nessun oggetto deve venire a contatto con l'anello estrattore del raccordo evitando così l'esercizio di qualsiasi forza indesiderata, anche solo laterale, che potrebbe causare la pressione dell'anello estrattore e conseguente rilascio del tubo.

Per il serraggio delle parti filettate del raccordo si raccomanda di attenersi alle coppie consigliate riportate a pag.6



Once the tubing is connected to the fitting, make sure that the tubing is not subject to any tensile strength and that the min. recommended bending radius stated in the tubing section of this catalogue is complied with (see page 337). To prevent any accidental tube release, no components have to come in touch with the release ring and exercise any unwanted pressure on the same. Indeed however lateral, any load on the release ring may cause the tube disconnection. To tighten threads, please check out our tightening torque chart illustrated at page 6.



Une fois effectué le branchement, s'assurer que le tube inséré dans le raccord n'est soumis à aucune force de traction. Egalement, il est nécessaire de respecter, lors du branchement du tube, le rayon minimum de courbure conseillé dans la section tubes de ce catalogue technique (voir la page 337).

Afin d'éviter le décrochage involontaire du tube, aucun objet ne doit entrer en contact avec la bague d'extraction du raccord, empêchant ainsi l'exercice de toute force indésirable, ne serait-ce que latérale, qui pourrait provoquer la pression de la bague d'extraction et donc le relâchement du tube.

Pour le serrage des parties filettées du raccordo, il est recommandé de s'en tenir aux couples de serrage conseillés et reportés à la page 6.



Nach der Schlauchverbindung, sicherstellen, dass der in die Verschraubung eingeführte Schlauch keinen Zugbelastungen ausgesetzt ist; beim Anschluss des Schlauchs muss der empfohlene Mindestbiegeradius eingehalten werden, gemäß den in diesem technischen Katalog im Schlauchabschnitt, angegebenen Hinweisen (siehe Seite 337).

Um das versehentliche Lösen des Schlauchs zu verhindern, darf kein Gegenstand den Lösering der Verschraubung berühren. Keine unerwünschte Kraft darf auch nicht seitlich einwirken und kein Druck soll auf den Lösering ausgeübt werden, denn dies das Schlauchlösen verursachen könnte.

Zum Festziehen der Gewinde sich an den, auf Seite 6, empfohlenen Drehmomente einhalten.

AP 12

Diritto maschio cilindrico

Parallel Straight, male

Union simple mâle cylindrique

Gerade Einschraubverschraubung, zylindrisch

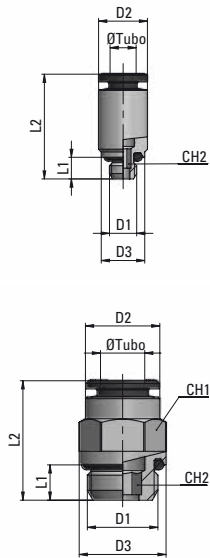

Tipo	Øe Tubo	D1	D2	D3	L1	L2	CH1	CH2	g $\Delta\Delta$
12 04 M5	4	M5x0,8	9	8	4	19	-	2,5	4,6
12 06 M5	6	M5x0,8	12	8	4	22	-	2,5	8,6
12 06 M12x1,5	6	M12x1,5	12	15	6,5	21	12	4	12,9
12 04 18	4	G1/8	9	13	5	16,5	9	3	6,1
12 06 18	6	G1/8	12	13,5	5	19,5	12	4	9
12 06 14	6	G1/4	12	16	6,5	19,5	12	4	12,7
12 08 18	8	G1/8	14	13	5	23,5	13	6	11,4
12 08 14	8	G1/4	14	16	6,5	21,5	14	6	13,5
12 08 38	8	G3/8	14	20	7	21	14	6	20,1
12 08 12	8	G1/2	14	25	8,5	23	14	6	32,6
12 10 14	10	G1/4	16	16	6,5	27,5	15	8	17,4
12 10 38	10	G3/8	16	20	7	25	16	8	22,6
12 10 12	10	G1/2	16	25	8,5	25,5	16	8	34,5
12 12 14	12	G1/4	19	16	6,5	28,5	19	8	26,2
12 12 38	12	G3/8	19	20	7	28,5	19	10	28,9
12 12 12	12	G1/2	19	25	8,5	26,5	19	10	36,1

AP 13

Diritto femmina

Female Straight

Union simple femelle

Gerade Aufschraubverschraubung

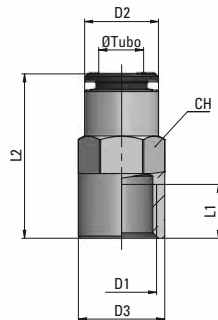

Tipo	Øe Tubo	D1	D2	D3	L1	L2	CH	g $\Delta\Delta$
13 04 18	4	G1/8	9	13	7,5	23,5	9	10
13 06 18	6	G1/8	12	14	7,5	26	12	15,1
13 06 14	6	G1/4	12	16	11	30	12	18,5
13 08 18	8	G1/8	14	13	7,5	26	14	17,5
13 08 14	8	G1/4	14	16	11	30	14	20,2
13 10 14	10	G1/4	16	16	11	32	16	24,4
13 10 38	10	G3/8	16	20	12	33,5	16	30,3

AP 16

Gomito maschio cilindrico girevole

Parallel Swivelling Elbow Fitting, male

Raccord à coude tournant, mâle cylindrique

Schwenkbare Winkelverschraubung, zylindrisch

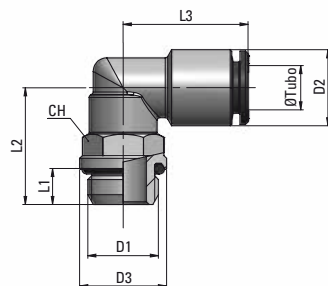

Tipo	Øe Tubo	D1	D2	D3	L1	L2	L3	CH	g $\Delta\Delta$
16 04 M5	4	M5x0,8	9	10	4	14	17,5	9	8,8
16 04 18	4	G1/8	9	14,5	5	18	19,5	13	15,7
16 06 M5	6	M5x0,8	12	10	4	14	20,5	9	11,9
16 06 18	6	G1/8	12	14,5	5	18	22	13	18,5
16 06 14	6	G1/4	12	16	6,5	21,5	22	13	21,8
16 08 18	8	G1/8	14	14,5	5	18	22,5	13	22
16 08 14	8	G1/4	14	16	6,5	21,5	22,5	13	25,3
16 08 38	8	G3/8	14	20	7	25,5	23	16	37,7
16 10 14	10	G1/4	16	16	6,5	22	26	16	34
16 10 38	10	G3/8	16	20	7	25,5	26	16	39,2
16 10 12	10	G1/2	16	25	8,5	27,5	26	16	43,2
16 12 14	12	G1/4	19	16	6,5	25,5	28,5	20	58,5
16 12 38	12	G3/8	19	20	7	26	28,5	20	56,1
16 12 12	12	G1/2	19	25	8,5	30,5	28,5	20	65,1

AP 21

T Centrale maschio cilindrico girevole

Swivelling Tee fitting, parallel

Raccord à Té tournant, mâle cylindrique

T-Verschraubung, schwenkbar und zylindrisch

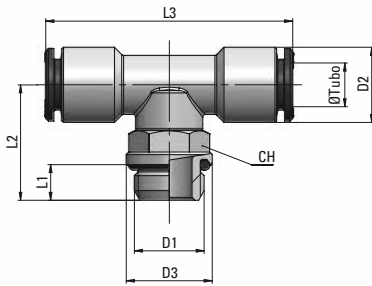

Tipo	Øe Tubo	D1	D2	D3	L1	L2	L3	CH	g ΔΔ
21 04 18	4	G1/8	9	14,5	5	18	39	13	20,2
21 06 18	6	G1/8	12	14,5	5	18	44	13	25,2
21 06 14	6	G1/4	12	16	6,5	21,5	44	13	29,1
21 08 18	8	G1/8	14	14,5	5	18	45	13	30,7
21 08 14	8	G1/4	14	16	6,5	21,5	45	13	33,6
21 10 14	10	G1/4	16	16	6,5	22	49	16	44,4
21 10 38	10	G3/8	16	20	7	25,5	49	16	49,7
21 12 38	12	G3/8	19	20	7	26	57	20	75,3
21 12 12	12	G1/2	19	25	8,5	30,5	57	20	82

AP 24

T Laterale maschio cilindrico girevole

Lateral Swivelling Tee fitting, parallel

Raccord à Té latéral cylindrique, tournant

T-Schwenkverschraubung, zylindrisch

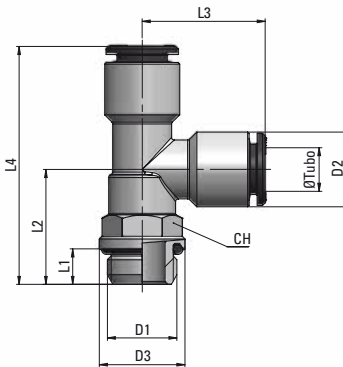

Tipo	Øe Tubo	D1	D2	D3	L1	L2	L3	L4	CH	g ΔΔ
24 04 18	4	G1/8	9	14,5	5	18	19,5	37,5	13	20,5
24 06 18	6	G1/8	12	14,5	5	18	22	40	13	26
24 06 14	6	G1/4	12	16	6,5	21,5	22	43,5	13	29,5
24 08 18	8	G1/8	14	14,5	5	18	22,5	40,5	13	30
24 08 14	8	G1/4	14	16	6,5	21,5	22,5	44	13	33,5
24 10 14	10	G1/4	16	16	6,5	22	26	48	16	44
24 10 38	10	G3/8	16	20	7	25,5	26	51,5	16	49
24 12 38	12	G3/8	19	20	7	26	28,5	54,5	20	73
24 12 12	12	G1/2	19	25	8,5	30,5	28,5	59	20	77

AP 25

Riduzione

Reducer

Réduction

Reduzierstück

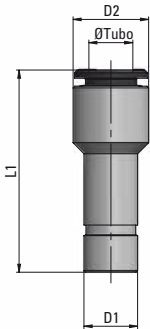

Tipo	Øe Tubo	D1	D2	L1	g ΔΔ
25 04 06	4	6	9	33,5	7
25 04 08	4	8	9	33,5	10
25 06 04	6	4	12	35,5	10
25 06 08	6	8	12	35	11,5
25 06 10	6	10	12	36,5	15,5
25 08 06	8	6	14	39,5	13,5
25 08 10	8	10	14	37	15
25 08 12	8	12	14	39	23
25 10 12	10	12	16	42	20
25 10 14	10	14	16	42	29,5
25 12 14	12	14	19	43	24

AP 26

Giunzione Intermedia

Union

Union simple égale

Gerade Verbindung

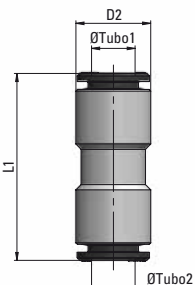

Tipo	Øe Tubo1	Øe Tubo2	D2	L1	g ΔΔ
26 04 04	4	4	9	28	6,8
26 06 06	6	6	12	33,5	15
26 06 04	6	4	12	31	14,7
26 08 08	8	8	14	34	18
26 08 06	8	6	14	34	21
26 10 10	10	10	16	38,5	22,5
26 10 08	10	8	16	36,5	25,2
26 12 12	12	12	19	41	36,6

AP 27

Giunzione Intermedia passaparete

Bulkhead union

Union traversée de cloison

Gerade Schottverschraubung

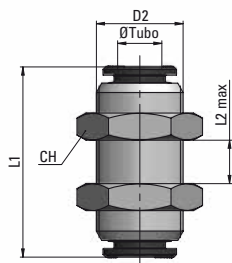

Tipo	Øe Tubo	D2	L1	L2 max	CH	g Δ
27 04 04	4	M12x1	28	11	16	23,5
27 06 06	6	M14x1	34	16	18	33
27 08 08	8	M16x1	34	17	20	39,5
27 10 10	10	M18x1	39	19	22	51,5
27 12 12	12	M20x1	41	20	24	60

AP 28

Gomito Intermedio

Union Elbow

Raccord à Coude

Winkelverschraubung

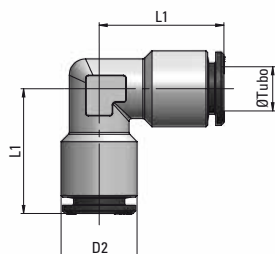

Tipo	Øe Tubo	D2	L1	L2	g Δ
28 04 04	4	9	17,5	9	9
28 06 06	6	12	20,5	16,5	16,5
28 08 08	8	14	22,5	22	22
28 10 10	10	16	25	29,5	29,5
28 12 12	12	19	26,5	48,5	48,5

AP 29

T Intermedio

Union Tee

T égal

T-Verschraubung

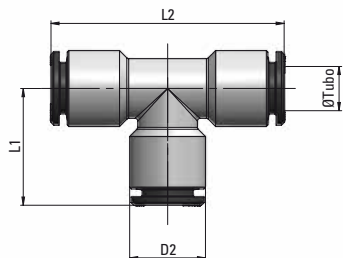

Tipo	Øe Tubo	D2	L1	L2	g Δ
29 04 04	4	9	17,5	35	12,5
29 06 06	6	12	20	40	22,5
29 08 08	8	14	21	42	28,4
29 10 10	10	16	24,5	49	39,2
29 12 12	12	19	26	52	61,3

AP 35

Anello singolo

Single Banjo Ring

Banjo simple

Ringstück

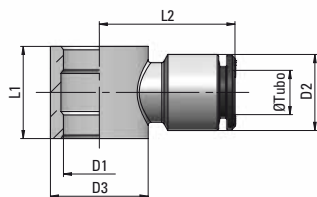

Tipo	Øe Tubo	D1	D2	D3	L1	L2	g Δ
35 04 M5	4	M5	9	10	10	18,5	7,7
35 04 M5 /R	4	7	9	10	10	18,5	6,6
35 04 18	4	1/8	9	14	15	20,5	13,5
35 06 M5 /R	6	7	12	10	10	21,5	10,1
35 06 18	6	1/8	12	14	15	22,5	15,5
35 06 14	6	1/4	12	18	17	24	21,6
35 08 18	8	1/8	14	14	15	23,5	16,7
35 08 14	8	1/4	14	18	17	24,5	22,8
35 10 14	10	1/4	16	18	17	27	27,2
35 10 38	10	3/8	16	22	20	29	39,5
35 12 38	12	3/8	19	22	20	29,5	38,8
35 12 12	12	1/2	19	27	24	31,5	56,9

/R = Solo per regolatori di flusso - For flow controls only - Seulement pour les réducteurs de débit - Nur für Drosselrückschlagventil

Y

Y Fitting

Raccord à Y

Y-Verschraubung

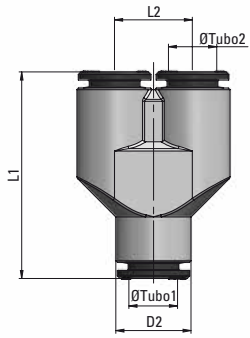

Tipo	Øe Tubo 1	Øe Tubo 2	D2	L1	L2	g Δ
37 04 04	4	4	9	29,5	9,5	13,5
37 06 06	6	6	12	36	12,5	32
37 06 04	6	4	12	36	12,5	36,1
37 08 08	8	8	14	37,5	14,5	42,5
37 08 06	8	6	14	37,5	14,5	51,1
37 10 10	10	10	16	44,5	16,5	62,7
37 10 08	10	8	16	44	16,5	74,9
37 12 12	12	12	19	49	19,5	95,8