

MV LINE



Raccordi a Funzione
Function Fittings
Raccords à fonction
Funktionsverschraubungen



.../C = Regolazione del flusso in Uscita
 Meter out flow control
 Réducteur de débit fonctionnant à échappement
 Abluftdrosselung

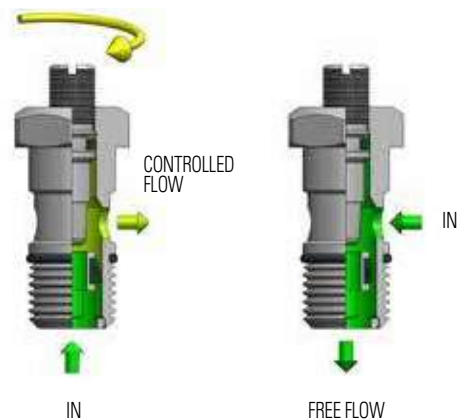

.../V = Regolazione del flusso in Ingresso
 Meter in flow control
 Réducteur de débit fonctionnant à l'admission
 Zuluftdrosselung

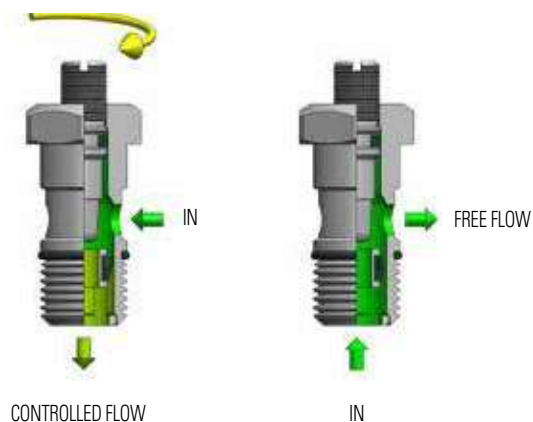

.../B = Regolazione del flusso in entrambe le direzioni
 Bidirectional flow control
 Réducteur de débit bidirectionnel
 Beidseitige Drosselung

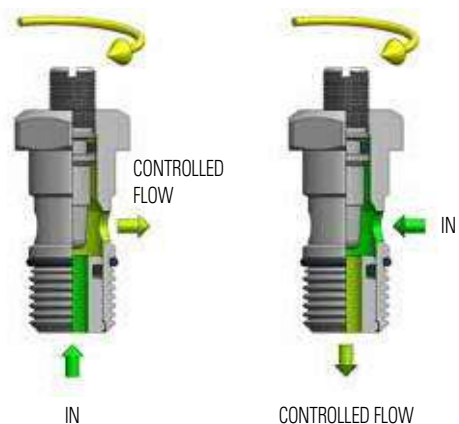

Questi dispositivi offrono la possibilità di regolare la portata d'aria in un circuito pneumatico. In base al tipo di regolatore impiegato, la regolazione può avvenire in entrambi i sensi (Regolatore Bidirezionale), oppure in un unico senso (Regolatore Unidirezionale). I Regolatori di Flusso Unidirezionali, risultano particolarmente adatti per la regolazione della velocità di cilindri pneumatici.

They can adjust the flow in a pneumatic circuit. Depending on the flow control used, the setting can be made both ways (Bidirectional Flow Control), or just one way (Unidirectional Flow Control). The Unidirectional Flow Control is particularly used to adjust the speed of pneumatic cylinders.

Leur fonction est d'assurer le réglage du débit dans un circuit pneumatique. Selon le réducteur employé, le réglage peut être effectué dans les deux sens (réducteur bidirectionnel) ou dans un seul sens (réducteur unidirectionnel). Le réducteur unidirectionnel est très utilisé pour le réglage de la vitesse de sortie de tige du vérin pneumatique.

Das Drosselrückschlagventil regelt den Durchfluss in einer pneumatischen Anlage. Je nach dem Drosselventil, kann die Drosselung auf beiden Seiten (beidseitiges Drosselrückschlagventil) oder einfach auf einer Seite erfolgen. (einseitiges Rückschlagventil). Besonders geeignet ist das einseitige Drosselrückschlagventil für die Regulierung der Zylindergeschwindigkeit.

1	2	3	4	5
Corpo Body Corps Körper	Spillo Needle Epingle Nadel	Bussola Cartridge Cartouche Patrone	Guarnizioni Seals Joint d'étanchéité Dichtung	Rondelle Gasket Bague Plastique Kunststoffring
Ottone UNI EN 12164 CW614N Nichelato Brass UNI EN 12164 CW614N Nickel plated Laiton UNI EN 12164 CW614N Nickelé Messing UNI EN 12164 CW614N vernickelt			NBR NBR NBR NBR	PA6 PA6 PA6 PA6



-20°C ÷ 70°C

0 ÷ 10 bar

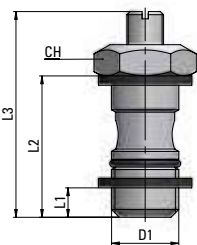
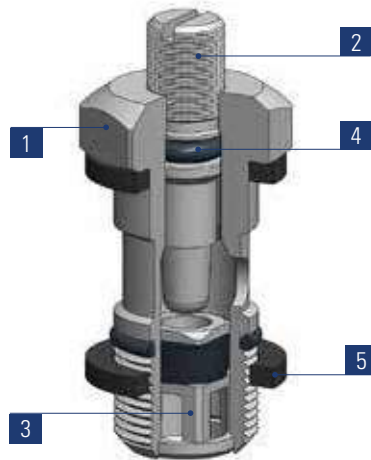

Tipo	D1	L1	L2	L3 max	CH	g Δ
15 00 M5	M5x0,8	4	16	25	8	5
15 00 18	G1/8	5	24	32	14	17
15 00 14	G1/4	6,5	27,5	40	17	33
15 00 38	G3/8	7	31	50	20	59
15 00 12	G1/2	9	38	61	26	107

Disponibile nelle versioni:

.../C



.../N



.../B



SPECIFICHE TECNICHE

Tubi di collegamento consigliati:
variabili in funzione del tipo di raccordo collegato al regolatore.

Campi di applicazione:
impianti pneumatici alimentati con aria filtrata e lubrificata.

DATA SHEET

Recommended tubings:
according to the fitting connected to the flow control.

Application field:
pneumatic installations fed with filtered, lubricated air.

REINSEIGNEMENTS TECHNIQUES

Tube conseillé:
en fonction du raccord monté sur le réducteur.

Domaines d'application:
circuits pneumatiques avec air filtré et lubrifié.

TECHNISCHE AUSKÜNFTE

Empfohlene Schläuche:
die Schläuche werden durch die am Drosselrückschlagventil montierte verschraubung bestimmt.

Anwendungsbereiche:
pneumatische Anlage mit gefilterter und geölter Druckluft.

MV 16		Regolatore di flusso con pomolo di regolazione	Flow Control with Handwheel	Réducteur de débit avec volant moleté	Drosselrückschlagventil mit Rändelkopf
1	2	3	4	5	6
Corpo Body Corps Körper	Spillo Needle Epingle Nadel	Pomolo Handwheel Volant moleté Rändelkopf	Bussola Cartridge Cartouche Patrone	Guarnizioni Seals Joint d'étanchéité Dichtung	Rondelle Gasket Bague Plastique Kunststoffring
Ottone UNI EN 12164 CW614N Nichelato Brass UNI EN 12164 CW614N Nickel plated Laiton UNI EN 12164 CW614N Nickelé Messing UNI EN 12164 CW614N vernickelt				NBR NBR NBR NBR	PA6 PA6 PA6 PA6



-20°C ÷ 70°C



0 ÷ 10 bar

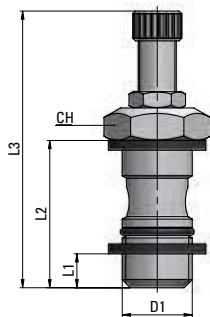
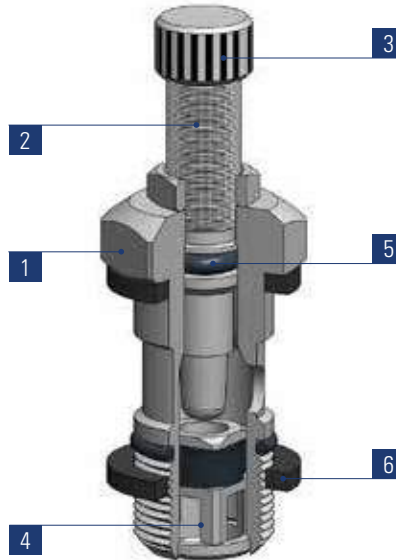

Tipo	D1	L1	L2	L3 max	CH	g Δ
16 00 M5	M5x0,8	4	16	38,5	8	6
16 00 18	G1/8	5	24	42,5	14	21
16 00 14	G1/4	6,5	27,5	51	17	35
16 00 38	G3/8	7	31	63	20	73
16 00 12	G1/2	9	38	81	26	136

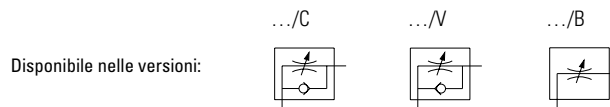

SPECIFICHE TECNICHE

Tubi di collegamento consigliati:
variabili in funzione del tipo di raccordo collegato al regolatore.

Campi di applicazione:
impianti pneumatici alimentati con aria filtrata e lubrificata.

DATA SHEET

Recommended tubings:
according to the fitting connected to the flow control.

Application field:
pneumatic installations fed with filtered, lubricated air.

REINSEIGNEMENTS TECHNIQUES

Tube conseillé:
en fonction du raccord monté sur le réducteur.

Domaines d'application:
circuits pneumatiques avec air filtré et lubrifié.

TECHNISCHE AUSKUNFTE

Empfohlene Schläuche:
die Schläuche werden durch die am Drosselrückschlagventil montierte verschraubung bestimmt.

Anwendungsbereiche:
pneumatische Anlage mit gefilterter und geölter Druckluft.

Regolatore con attacco filettato

Male Flow Control

Réducteur de débit fileté

Drosselrückschlagventil mit Gewinde

MV 17

1	2	3	4	5	6
Corpo Body Corps Körper	Spillo Needle Epingle Nadel	Bussola Cartridge Cartouche Patrone	Guarnizioni Seals Joint d'étanchéité Dichtung	Anello Banjo Ring Banjo Steckverschraubungen	Rondelle Gasket Bague Plastique Kunststoffring
Ottone UNI EN 12164 CW614N Nichelato Brass UNI EN 12164 CW614N Nickel plated Laiton UNI EN 12164 CW614N Nickelé Messing UNI EN 12164 CW614N vernickelt			NBR NBR NBR NBR	Raccordo serie RA RA line standard fittings Raccords série RA RA Verschraubung	PA6 PA6 PA6 PA6

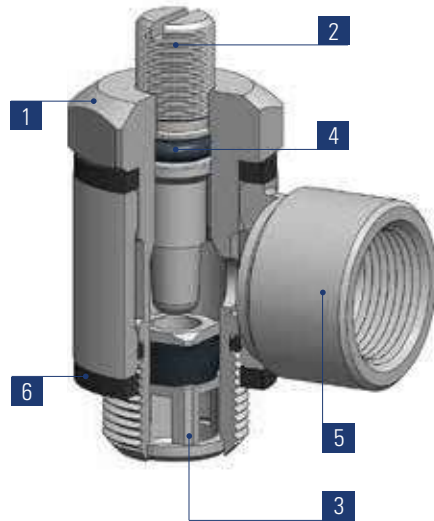

P = 6 bar - Δp = 1 bar

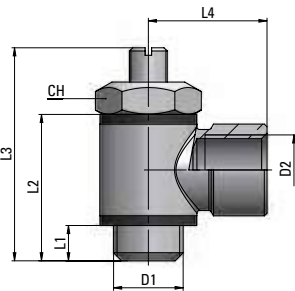
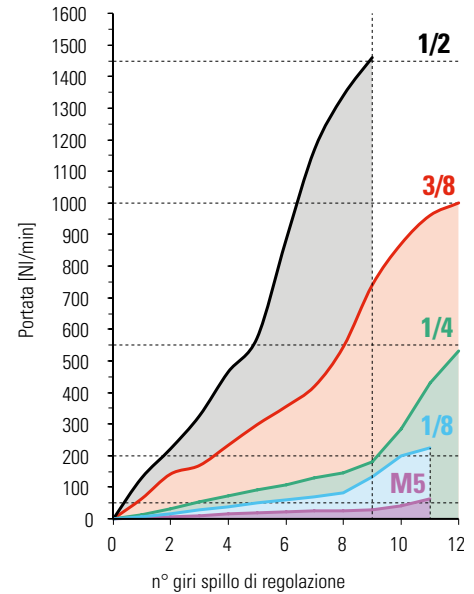

Tipo	D1	D2	L1	L2	L3 max	L4	CH	g Δ
17 00 M5	M5x0,8	M5x0,8	4	16	25	11	8	10
17 00 18	G1/8	G1/8	5	24	32	16	14	32
17 00 14	G1/4	G1/4	6,5	27,5	40	22	17	58
17 00 38	G3/8	G3/8	7	31	50	26	20	98
17 00 12	G1/2	G1/2	9	38	61	32	26	173

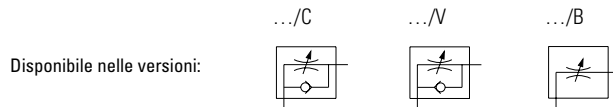

Una volta effettuata l'installazione del regolatore l'anello non è più orientabile.
The banjo ring no longer swivel after flow control installation.
Les banjos ne tournent pas après l'installation du réducteur.
Der Schwenkring bleibt nach der Montage des Drosselrückschlagventiles fest.

Campi di applicazione:
impianti pneumatici alimentati con aria filtrata e lubrificata.

Application field:
pneumatic installations fed with filtered, lubricated air.

Domaines d'application:
circuits pneumatiques avec air filtré et lubrifié.

Anwendungsbereiche:
pneumatische Anlage mit gefilterter und geölter Druckluft.

MV 40	Regolatore con attacco filettato e pomolo di regolazione		Male Flow Control with Handwheel		Réducteur de débit fileté avec volant moleté		Drosselrückschlagventil mit Gewinde und Rändelkopf	
1	2	3	4	5	6	7		
Corpo Body Corps Körper	Spillo Needle Epingle Nadel	Pomolo Handwheel Volant moleté Rändelkopf	Bussola Cartridge Cartouche Patrone	Guarnizioni Seals Joint d'étanchéité Dichtung	Anello Banjo Ring Banjo Steckverschraubungen	Rondelle Gasket Bague Plastique Kunststoffring		
Ottone UNI EN 12164 CW614N Nichelato Brass UNI EN 12164 CW614N Nickel plated Laiton UNI EN 12164 CW614N Nickelé Messing UNI EN 12164 CW614N vernickelt				NBR NBR NBR NBR	Raccordo serie RA RA line standard fittings Raccords série RA RA Verschraubung	PA6 PA6 PA6 PA6		



-20°C ÷ 70°C



0 ÷ 10 bar

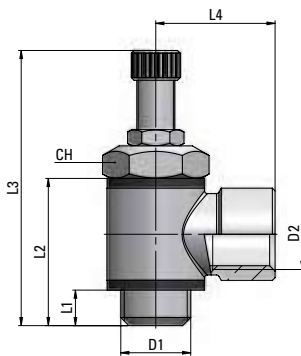
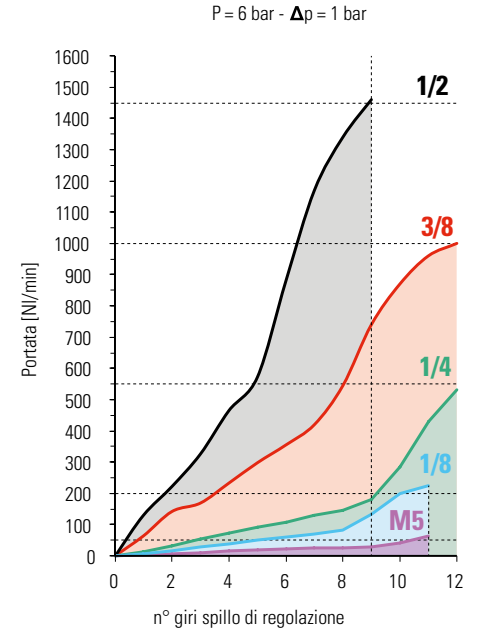
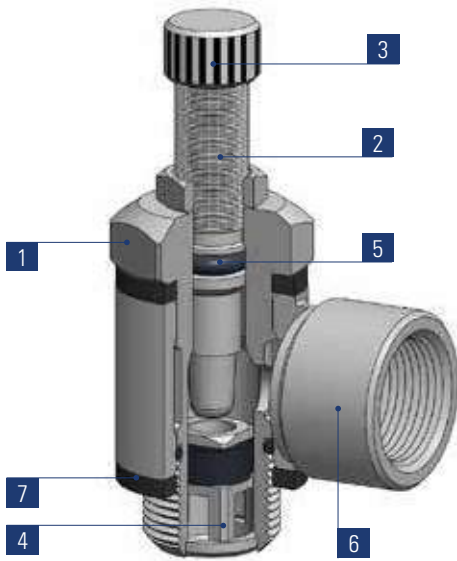

Tipo	D1	D2	L1	L2	L3 max	L4	CH	g Δ
40 00 M5	M5x0,8	M5x0,8	4	16	38,5	11	8	12
40 00 18	G1/8	G1/8	5	24	42,5	16	14	37
40 00 14	G1/4	G1/4	6,5	27,5	51	22	17	65
40 00 38	G3/8	G3/8	7	31	63	26	20	112
40 00 12	G1/2	G1/2	9	38	81	32	26	202

.../C .../V .../B

Disponibile nelle versioni:

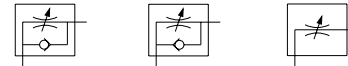

Una volta effettuata l'installazione del regolatore l'anello non è più orientabile.
The banjo ring no longer swivel after flow control installation.
Les banjos ne tournent pas après l'installation du réducteur.
Der Schwenkring bleibt nach der Montage des Drosselrückschlagventiles fest.

Campi di applicazione:
impianti pneumatici alimentati con aria filtrata e lubrificata.

Application field:
pneumatic installations fed with filtered, lubricated air.

Domaines d'application:
circuits pneumatiques avec air filtré et lubrifié.

Anwendungsbereiche:
pneumatische Anlage mit gefilterter und geölter Druckluft.

Regolatore con raccordo orientabile automatico in ottone

Brass Flow Control with swivelling push-in fitting

Réducteur de débit avec raccord automatique tournant en laiton

Drosselrückschlagventil mit schwenkbarer Steckverschraubung aus Messing

MV 18

1	2	3	4	5
Corpo Body Corps Körper	Spillo Needle Epingle Nadel	Bussola Cartridge Cartouche Patrone	Guarnizioni Seals Joint d'étanchéité Dichtung	Anello Banjo Ring Banjo Steckverschraubungen
Ottone UNI EN 12164 CW614N Nichelato Brass UNI EN 12164 CW614N Nickel plated Laiton UNI EN 12164 CW614N Nickelé Messing UNI EN 12164 CW614N vernickelt			NBR NBR NBR NBR	Raccordo Automatico serie MA MA line push-in fittings Raccords instantanés série MA MA Steckverschraubungen



-20°C ÷ 70°C

0 ÷ 10 bar

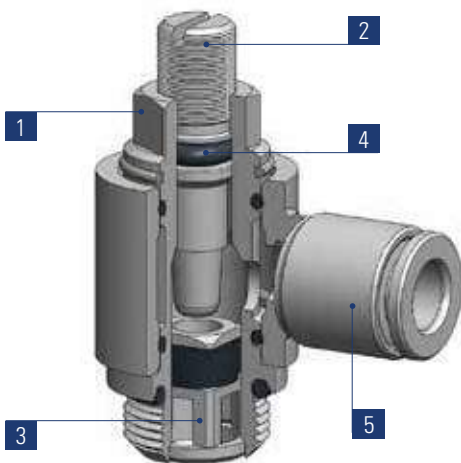

P = 6 bar - Δp = 1 bar

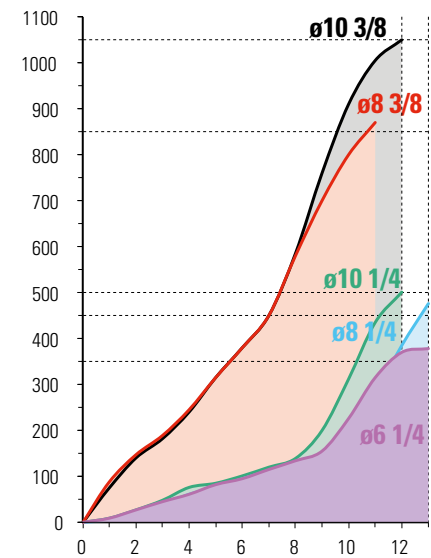
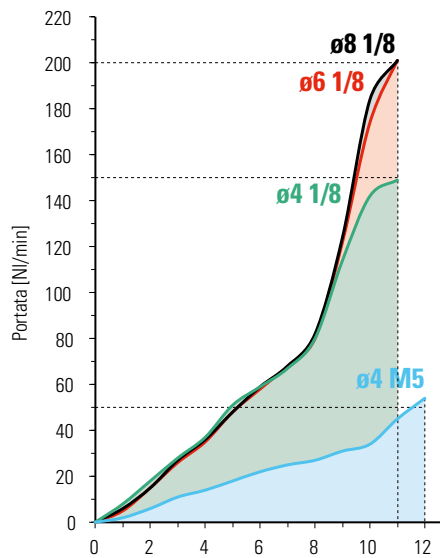

n° giri spillo di regolazione

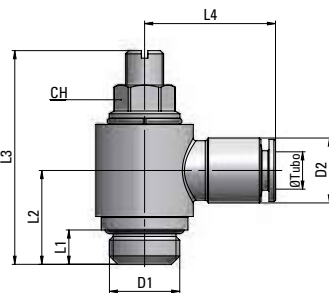

Tipo	Øe Tubo	D1	D2	L1	L2	L3 max	L4	CH	g Δ
18 04 M5	4	M5x0,8	9	4	11,5	25,5	18	6	12
18 04 18	4	G1/8	9	5	15,5	32	19,5	9	29
18 06 M5	6	M5x0,8	12	4	11,5	25,5	21,5	6	15,5
18 06 18	6	G1/8	12	5	15,5	32	22	9	27
18 06 14	6	G1/4	12	6,5	17,5	40	23,5	10	49
18 08 18	8	G1/8	14	5	15,5	32	22,5	9	31
18 08 14	8	G1/4	14	6,5	17,5	40	24	10	49
18 08 38	8	G3/8	14	9	22	50	26	14	89
18 10 14	10	G1/4	16	6,5	17,5	40	26,5	10	53
18 10 38	10	G3/8	16	9	22	50	28	14	86

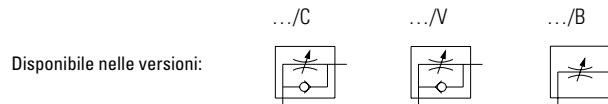

L'anello rimane orientabile anche dopo l'installazione del regolatore.
The banjo ring swivels also after flow control installation.
Les banjos peuvent être orientés après l'installation du réducteur.
Der Schwenkring kann nach der Montage des Drosselrückschlagventiles noch orientiert werden.

SPECIFICHE TECNICHE

Tubi di collegamento consigliati:
PA11, PA12, PA6, Poliuretano PU (98 Shore A)

Campi di applicazione:
impianti pneumatici alimentati con aria filtrata e lubrificata.

DATA SHEET

Recommended tubings:
PA11, PA12, PA6, Polyurethane PU (98 Shore A)

Application field:
pneumatic installations fed with filtered, lubricated air.

REINSEIGNEMENTS TECHNIQUES

Tube conseillé:
PA11, PA12, PA6, Polyurethane PU (98 Shore A).

Domaines d'application:
circuits pneumatiques avec air filtré et lubrifié.

TECHNISCHE AUSKÜNFTE

Empfohlene Schläuche:
PA11, PA12, PA6, Polyurethan PU (98 Shore A).

Anwendungsbereiche:
pneumatische Anlage mit gefilterter und geölter Druckluft.

MV 41

Regolatore con raccordo orientabile automatico in ottone e pomolo di regolazione

Brass Flow Control with swivelling push-in fitting and Handwheel

Réducteur de débit avec raccord automatique tournant en laiton et volant moleté

Messing Drosselrückschlagventil mit schwenkbarer Steckverschraubung und Rändelkopf

1	2	3	4	5	6
Corpo Body Corps Körper	Spillo Needle Epingle Nadel	Pomolo Handwheel Volant moleté Rändelkopf	Bussola Cartridge Cartouche Patrone	Guarnizioni Seals Joint d'étanchéité Dichtung	Anello Banjo Ring Banjo Steckverschraubungen
Ottone UNI EN 12164 CW614N Nichelato Brass UNI EN 12164 CW614N Nickel plated Laiton UNI EN 12164 CW614N Nickelé Messing UNI EN 12164 CW614N vernickelt				NBR NBR NBR NBR	Raccordo Automatico serie MA MA line push-in fittings Raccords instantanés série MA MA Steckverschraubungen

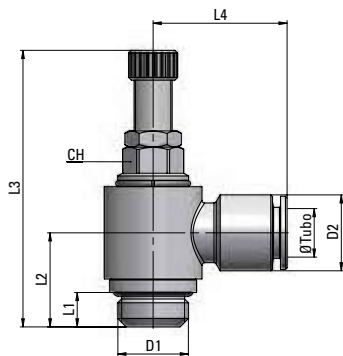
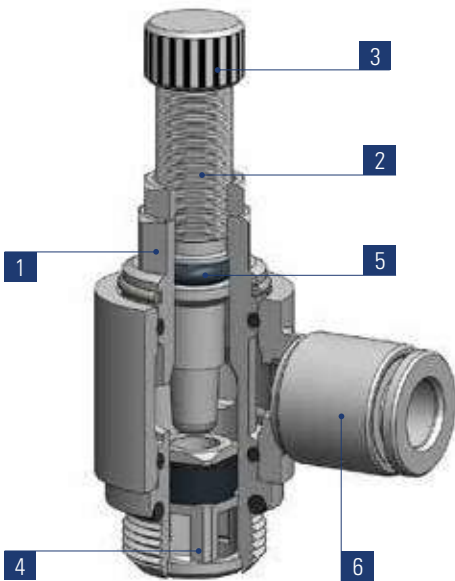

P = 6 bar - Δp = 1 bar

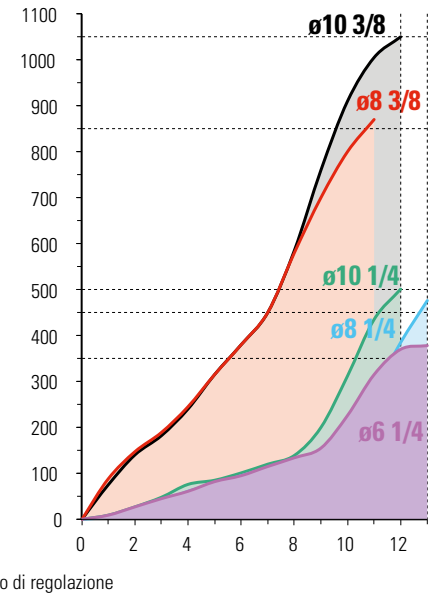
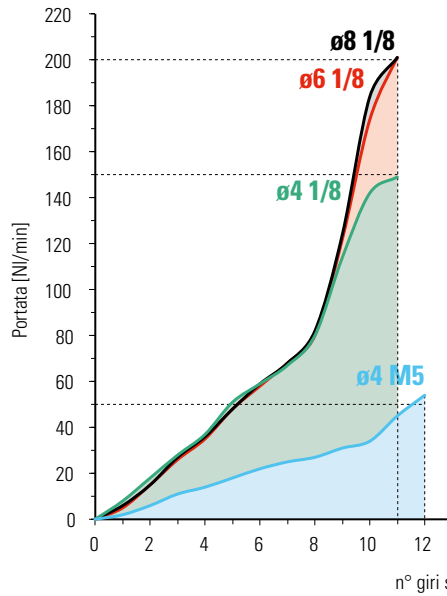

Tipo	Øe Tubo	D1	D2	L1	L2	L3 max	L4	CH	g Δ
41 04 M5	4	M5x0,8	9	4	11,5	39	18	6	13
41 04 18	4	G1/8	9	5	15,5	42	19,5	9	32
41 06 M5	6	M5x0,8	12	4	11,5	39	21,5	6	16,9
41 06 18	6	G1/8	12	5	15,5	42	22	9	34
41 06 14	6	G1/4	12	6,5	17,5	51	23,5	10	54
41 08 18	8	G1/8	14	5	15,5	42	22,5	9	35
41 08 14	8	G1/4	14	6,5	17,5	51	24	10	55
41 08 38	8	G3/8	14	9	22	63	26	14	99
41 10 14	10	G1/4	16	6,5	17,5	51	26,5	10	62
41 10 38	10	G3/8	16	9	22	63	28	14	105

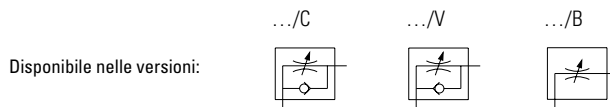

L'anello rimane orientabile anche dopo l'installazione del regolatore.
The banjo ring swivels also after flow control installation.
Les banjos peuvent être orientés après l'installation du réducteur.
Der Schwenkring kann nach der Montage des Drosselrückschlagventiles noch orientiert werden.

SPECIFICHE TECNICHE

Tubi di collegamento consigliati:
PA11, PA12, PA6, Poliuretano PU
(98 Shore A)

Campi di applicazione:
impianti pneumatici alimentati con aria
filtrata e lubrificata.

DATA SHEET

Recommended tubings:
PA11, PA12, PA6, Polyurethane PU
(98 Shore A)

Application field:
pneumatic installations fed with filtered,
lubricated air.

REINSEIGNEMENTS TECHNIQUES

Tube conseillé:
PA11, PA12, PA6, Polyurethane PU
(98 Shore A)

Domaines d'application:
circuits pneumatiques avec air filtré
et lubrifié.

TECHNISCHE AUSKÜNFTE

Empfohlene Schläuche:
PA11, PA12, PA6, Polyurethan PU
(98 Shore A)

Anwendungsbereiche:
pneumatische Anlage mit gefilterter und
geölter Druckluft.

Regolatore con raccordo orientabile a calzamento

Flow Control with swivelling push-on fitting

Réducteur de débit avec raccord à écrou tournant

Drosselrückschlagventil mit schwenkbarer Überwurfmutterverschraubung

MV 20

1	2	3	4	5
Corpo Body Corps Körper	Spillo Needle Epingle Nadel	Bussola Cartridge Cartouche Patrone	Guarnizioni Seals Joint d'étanchéité Dichtung	Anello Banjo Ring Banjo Steckverschraubungen
Ottone UNI EN 12164 CW614N Nichelato Brass UNI EN 12164 CW614N Nickel plated Laiton UNI EN 12164 CW614N Nickelé Messing UNI EN 12164 CW614N vernickelt			NBR NBR NBR NBR	Raccordo a Calzamento serie MC MC line push-on fittings Raccords à coiffe série MC MC Verschraubung

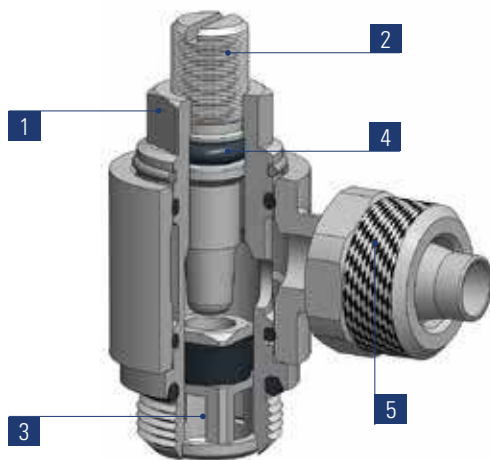

P = 6 bar - Δp = 1 bar

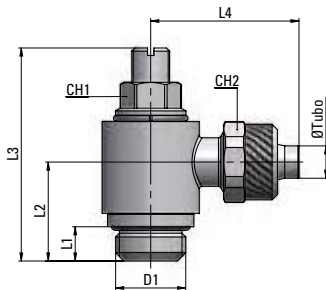
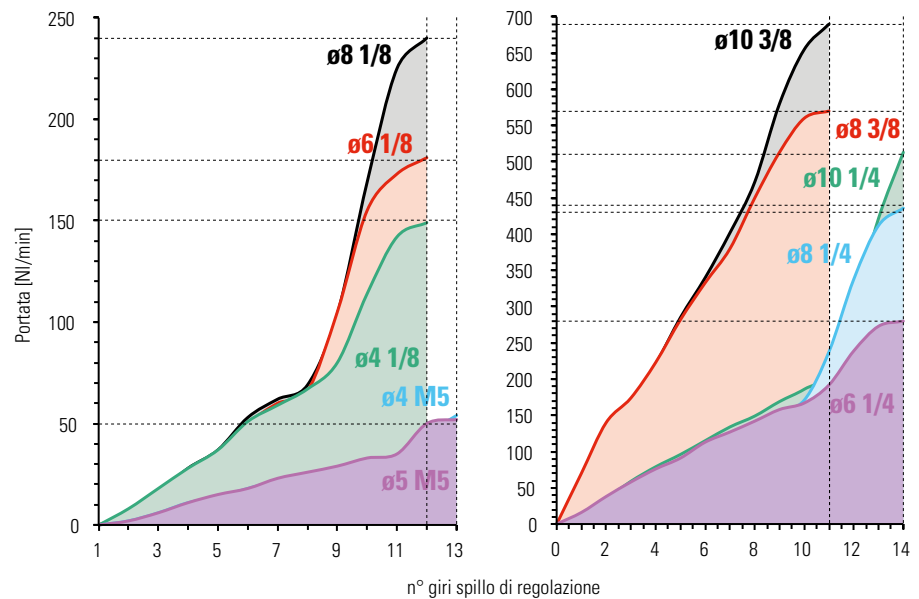

Tipo	Øe Tubo	D1	D2	L1	L2	L3 max	L4	CH	g Δ
20 04 M5	4-2,5	M5x0,8	4	11,5	25,5	15,5	6	7	11
20 05 M5	5-3	M5x0,8	4	11,5	25,5	19	6	8	11,5
20 05 18	5-3	G1/8	5	15,5	32	25	9	12	33
20 06 M5	6-4	M5x0,8	4	11,5	25,5	19	6	9	12
20 06 18	6-4	G1/8	5	15,5	32	25	9	12	33
20 06 14	6-4	G1/4	6,5	17,5	40	26,5	10	12	52
20 08 18	8-6	G1/8	5	15,5	32	25	9	14	33
20 08 14	8-6	G1/4	6,5	17,5	40	27,5	10	14	54
20 08 38	8-6	G3/8	9	22	50	29,5	14	14	90
20 10 14	10-8	G1/4	6,5	17,5	40	28,5	10	16	56
20 10 38	10-8	G3/8	9	22	50	30,5	14	16	92

.../C .../V .../B

Disponibile nelle versioni:

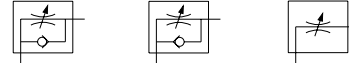

L'anello rimane orientabile anche dopo l'installazione del regolatore.
The banjo ring swivels also after flow control installation.
Les banjos peuvent être orientés après l'installation du réducteur.
Der Schwenkring kann nach der Montage des Drosselrückschlagventiles noch orientiert werden.

SPECIFICHE TECNICHE

Tubi di collegamento consigliati:
PA11, PA12, PA6, Poliuretano PU (98 Shore A)

Campi di applicazione:
impianti pneumatici alimentati con aria filtrata e lubrificata.

DATA SHEET

Recommended tubings:
PA11, PA12, PA6, Polyurethane PU (98 Shore A)

Application field:
pneumatic installations fed with filtered, lubricated air.

REINSEIGNEMENTS TECHNIQUES

Tube conseillé:
PA11, PA12, PA6, Polyurethane PU (98 Shore A).

Domaines d'application:
circuits pneumatiques avec air filtré et lubrifié.

TECHNISCHE AUSKÜNFTE

Empfohlene Schläuche:
PA11, PA12, PA6, Polyurethan PU (98 Shore A).

Anwendungsbereiche:
pneumatische Anlage mit gefilterter und geölter Druckluft.

MV 42

Regolatore con raccordo orientabile a calzamento in ottone e pomolo di regolazione

Brass Flow Control with swivelling push-on fitting and Handwheel

Réducteur de débit avec raccord à écrou tournant en laiton et volant moleté

Messing Drosselrückschlagventil mit schwenkbarer Überwurfmutterverschraubung und Rändelkopf

1	2	3	4	5	6
Corpo Body Corps Körper	Spillo Needle Epingle Nadel	Pomolo Handwheel Volant moleté Rändelkopf	Bussola Cartridge Cartouche Patrone	Guarnizioni Seals Joint d'étanchéité Dichtung	Anello Banjo Ring Banjo Steckverschraubungen
Ottone UNI EN 12164 CW614N Nichelato Brass UNI EN 12164 CW614N Nickel plated Laiton UNI EN 12164 CW614N Nickelé Messing UNI EN 12164 CW614N vernickelt				NBR NBR NBR NBR	Raccordo a Calzamento serie MC MC line push-on fittings Raccords à coiffe série MC MC Verschraubung

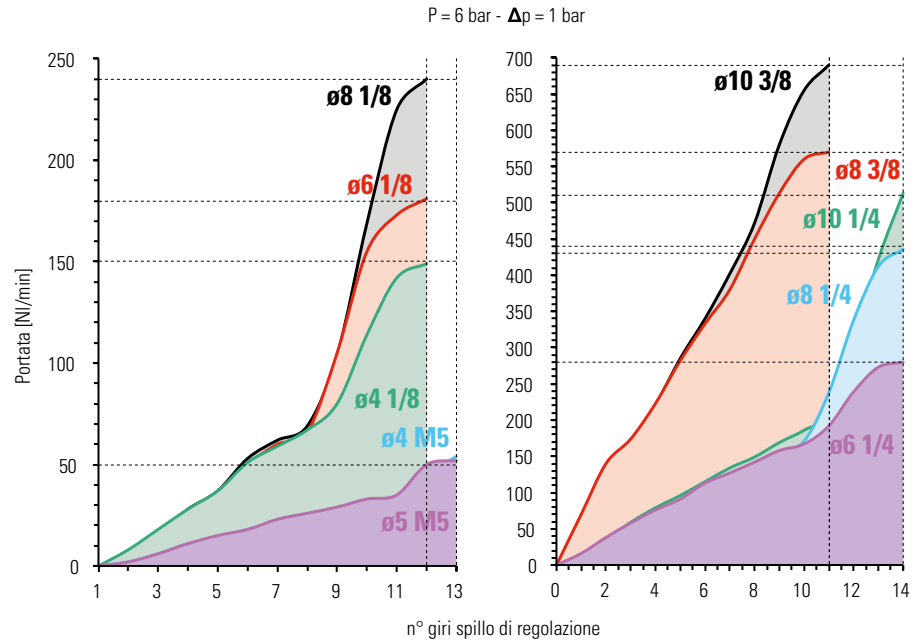
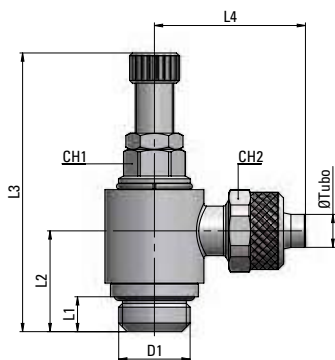
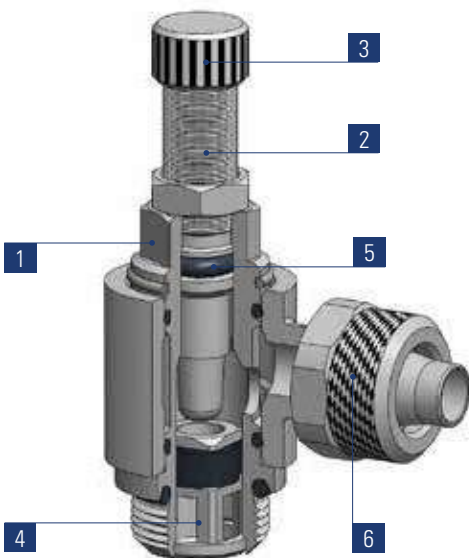
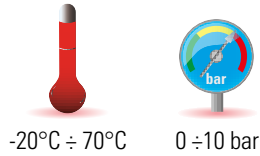

Tipo	Øe Tubo	D1	L1	L2	L3 max	L4	CH1	CH2	g Δ
42 04 M5	4-2,5	M5x0,8	4	11,5	39	15,5	6	7	12
42 05 M5	5-3	M5x0,8	4	11,5	39	19	6	8	13
42 05 18	5-3	G1/8	5	15,5	42,5	25	9	12	37
42 06 M5	6-4	M5x0,8	4	11,5	39	19	6	9	14
42 06 18	6-4	G1/8	5	15,5	42,5	25	9	12	37
42 06 14	6-4	G1/4	6,5	17,5	51	26,5	10	12	61
42 08 18	8-6	G1/8	5	15,5	42,5	25	9	14	38
42 08 14	8-6	G1/4	6,5	17,5	51	27,5	10	14	60
42 08 38	8-6	G3/8	9	22	72	29,5	14	14	105
42 10 14	10-8	G1/4	6,5	17,5	51	28,5	10	16	62
42 10 38	10-8	G3/8	9	22	72	30,5	14	16	108

Disponibile nelle versioni:

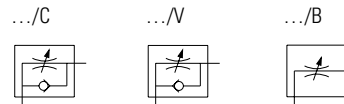

L'anello rimane orientabile anche dopo l'installazione del regolatore.
The banjo ring swivels also after flow control installation.
Les banjos peuvent être orientés après l'installation du réducteur.
Der Schwenkring kann nach der Montage des Drosselrückschlagventiles noch orientiert werden.

SPECIFICHE TECNICHE

Tubi di collegamento consigliati:
PA11, PA12, PA6, Poliuretano PU (98 Shore A)

Campi di applicazione:
impianti pneumatici alimentati con aria filtrata e lubrificata.

DATA SHEET

Recommended tubings:
PA11, PA12, PA6, Polyurethane PU (98 Shore A)

Application field:
pneumatic installations fed with filtered, lubricated air.

REINSEIGNEMENTS TECHNIQUES

Tube conseillé:
PA11, PA12, PA6, Polyurethane PU (98 Shore A)

Domaines d'application:
circuits pneumatiques avec air filtré et lubrifié.

TECHNISCHE AUSKUNFTE

Empfohlene Schläuche:
PA11, PA12, PA6, Polyurethan PU (98 Shore A)

Anwendungsbereiche:
pneumatische Anlage mit gefilterter und geölter Druckluft.

Regolatore con raccordo orientabile automatico in resina acetale

Flow Control with Swivelling acetal push-in fitting

Réducteur de débit avec raccord automatique tournant en résine acétal

Drosselrückschlagventil mit schwenkbarer Steckverschraubung aus Kunststoff

MV 38

1	2	3	4	5
Corpo Body Corps Körper	Spillo Needle Epingle Nadel	Bussola Cartridge Cartouche Patrone	Guarnizioni Seals Joint d'étanchéité Dichtung	Anello Banjo Ring Banjo Steckverschraubungen
Ottone UNI EN 12164 CW614N Nichelato Brass UNI EN 12164 CW614N Nickel plated Laiton UNI EN 12164 CW614N Nickelé Messing UNI EN 12164 CW614N vernickelt			NBR NBR NBR NBR	Raccordo Automatico serie MB MB line push-in fittings Raccords instantanés série MB MB Steckverschraubungen

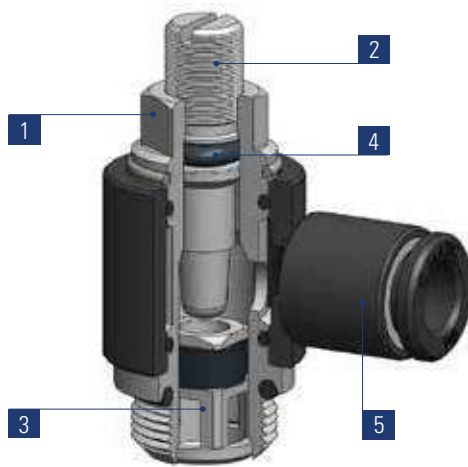

P = 6 bar - Δp = 1 bar

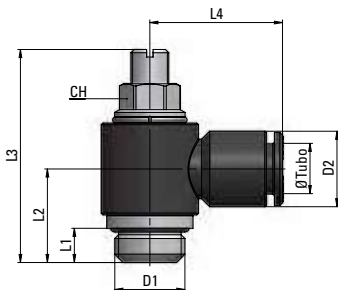
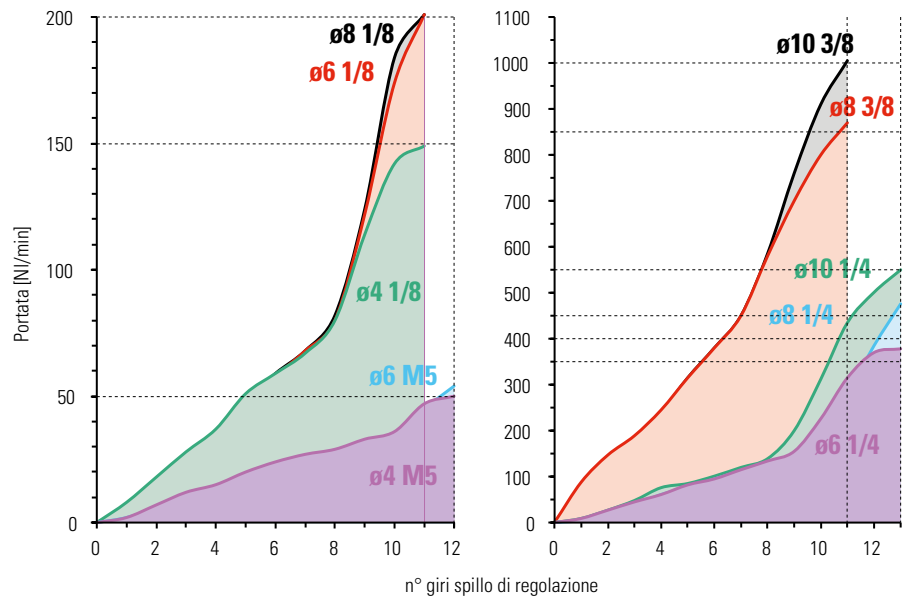

Tipo	Øe Tubo	D1	D2	L1	L2	L3 max	L4	CH	g Δ
38 04 M5	4	M5x0,8	9,7	4	11,5	25,5	17	6	7
38 04 18	4	G1/8	9,7	5	15,5	32	18,5	9	19
38 06 M5	6	M5x0,8	12	4	11,5	25,5	20,5	6	8
38 06 18	6	G1/8	12	5	15,5	32	22	9	16
38 06 14	6	G1/4	12	6,5	17,5	40	23,5	10	32
38 08 18	8	G1/8	14	5	15,5	32	22,5	9	16
38 08 14	8	G1/4	14	6,5	17,5	40	24	10	32
38 08 38	8	G3/8	14	9	22	50	26	14	59
38 10 14	10	G1/4	16	6,5	17,5	40	26,5	10	33
38 10 38	10	G3/8	16	9	22	50	28	14	60

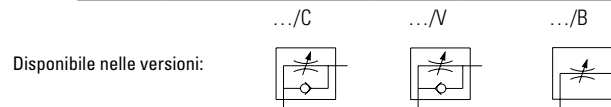

L'anello rimane orientabile anche dopo l'installazione del regolatore.
The banjo ring swivels also after flow control installation.
Les banjos peuvent être orientés après l'installation du réducteur.
Der Schwenkring kann nach der Montage des Drosselrückschlagventiles noch orientiert werden.

SPECIFICHE TECNICHE

Tubi di collegamento consigliati:
PA11, PA12, PA6, Poliuretano PU
(98 Shore A)

Campi di applicazione:
impianti pneumatici alimentati con aria
filtrata e lubrificata.

DATA SHEET

Recommended tubings:
PA11, PA12, PA6, Polyurethane PU
(98 Shore A)

Application field:
pneumatic installations fed with filtered,
lubricated air.

REINSEIGNEMENTS TECHNIQUES

Tube conseillé:
PA11, PA12, PA6, Polyurethane PU
(98 Shore A).

Domaines d'application:
circuits pneumatiques avec air filtré
et lubrifié.

TECHNISCHE AUSKÜNFTE

Empfohlene Schläuche:
PA11, PA12, PA6, Polyurethan PU
(98 Shore A).

Anwendungsbereiche:
pneumatische Anlage mit gefilterter und
geölter Druckluft.

MV 36

Regolatore con raccordo orientabile automatico in resina acetalica e pomolo di regolazione

Flow Control with Swivelling acetal push-in fitting and Handwheel

Réducteur de débit avec raccord automatique tournant en résine acétal et volant moleté

Drosselrückschlagventil mit schwenkbarer Steckverschraubung aus Kunststoff und Rändelkopf

1	2	3	4	5	6
Corpo Body Corps Körper	Spillo Needle Epingle Nadel	Pomolo Handwheel Volant moleté Rändelkopf	Bussola Cartridge Cartouche Patrone	Guarnizioni Seals Joint d'étanchéité Dichtung	Anello Banjo Ring Banjo Steckverschraubungen
Ottone UNI EN 12164 CW614N Nichelato Brass UNI EN 12164 CW614N Nickel plated Laiton UNI EN 12164 CW614N Nickelé Messing UNI EN 12164 CW614N vernickelt				NBR NBR NBR NBR	Raccordo Automatico serie MB MB line push-in fittings Raccords instantanés série MB MB Steckverschraubungen

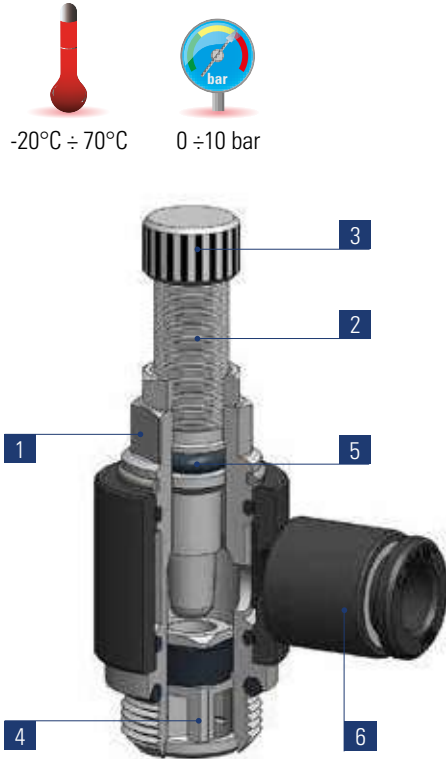

-20°C ÷ 70°C

0 ÷ 10 bar

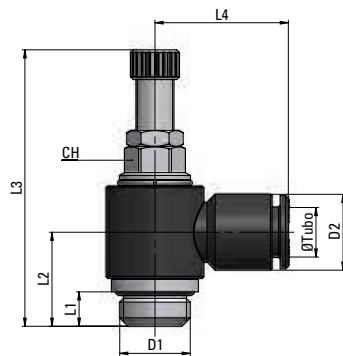
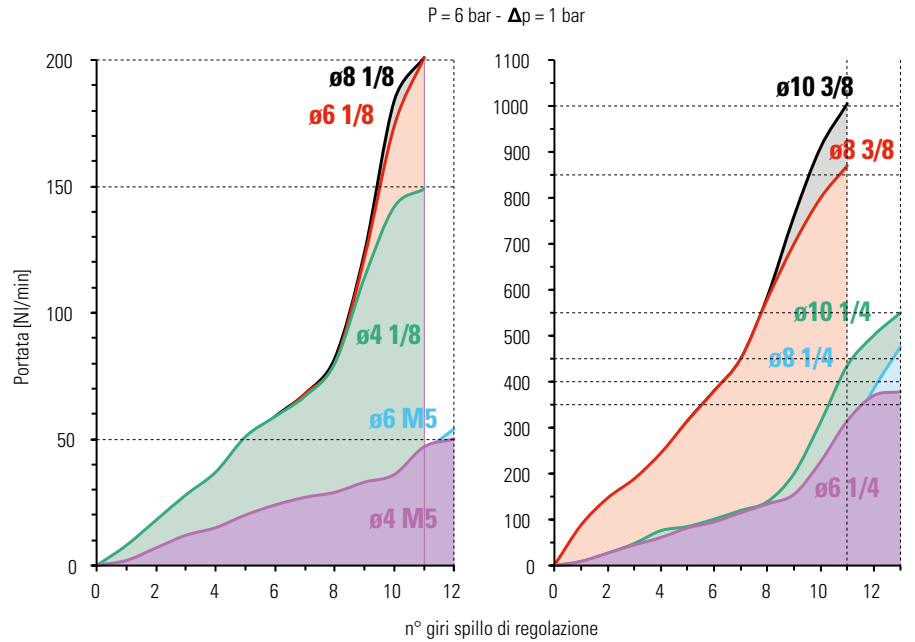

Tipo	Øe Tubo	D1	D2	L1	L2	L3 max	L4	CH	g Δ
36 04 M5	4	M5x0,8	9,7	4	11,5	39	17	6	9
36 04 18	4	G1/8	9,7	5	15,5	42	18,5	9	21
36 06 M5	6	M5x0,8	12	4	11,5	39	20,5	6	9,5
36 06 18	6	G1/8	12	5	15,5	42	22	9	22
36 06 14	6	G1/4	12	6,5	17,5	51	23,5	10	38
36 08 18	8	G1/8	14	5	15,5	42	22,5	9	22
36 08 14	8	G1/4	14	6,5	17,5	51	24	10	38
36 08 38	8	G3/8	14	9	22	63	26	14	72
36 10 14	10	G1/4	16	6,5	17,5	51	26	10	39
36 10 38	10	G3/8	16	9	22	63	28	14	74

Disponibile nelle versioni: .../C .../V .../B



L'anello rimane orientabile anche dopo l'installazione del regolatore.
The banjo ring swivels also after flow control installation.
Les banjos peuvent être orientés après l'installation du réducteur.
Der Schwenkring kann nach der Montage des Drosselrückschlagventiles noch orientiert werden.

SPECIFICHE TECNICHE

Tubi di collegamento consigliati:
PA11, PA12, PA6, Poliuretano PU (98 Shore A)

Campi di applicazione:
impianti pneumatici alimentati con aria filtrata e lubrificata.

DATA SHEET

Recommended tubings:
PA11, PA12, PA6, Polyurethane PU (98 Shore A)

Application field:
pneumatic installations fed with filtered, lubricated air.

REINSEIGNEMENTS TECHNIQUES

Tube conseillé:
PA11, PA12, PA6, Polyurethane PU (98 Shore A)

Domaines d'application:
circuits pneumatiques avec air filtré et lubrifié.

TECHNISCHE AUSKUNFTE

Empfohlene Schläuche:
PA11, PA12, PA6, Polyurethan PU (98 Shore A)

Anwendungsbereiche:
pneumatische Anlage mit gefilterter und geölter Druckluft.

Regolatore con raccordo automatico in resina acetalica

Flow Control with acetal push-in fitting

Réducteur de débit avec raccord automatique en résine acétal

Drosselrückschlagventil mit Steckverschraubung aus Kunststoff

MV 39

1	2	3	4	5	6
Corpo Body Corps Körper	Spillo Needle Epingle Nadel	Bussola Cartridge Cartouche Patrone	Guarnizioni Seals Joint d'étanchéité Dichtung	Anello Banjo Ring Banjo Steckverschraubungen	Rondelle Gasket Bague Plastique Kunststoffring
Ottone UNI EN 12164 CW614N Nichelato Brass UNI EN 12164 CW614N Nickel plated Laiton UNI EN 12164 CW614N Nickelé Messing UNI EN 12164 CW614N vernickelt			NBR NBR NBR NBR	Raccordo Automatico serie MB VB line push-in fittings Raccords instantanés série MB VB Steckverschraubungen	PA6 PA6 PA6 PA6

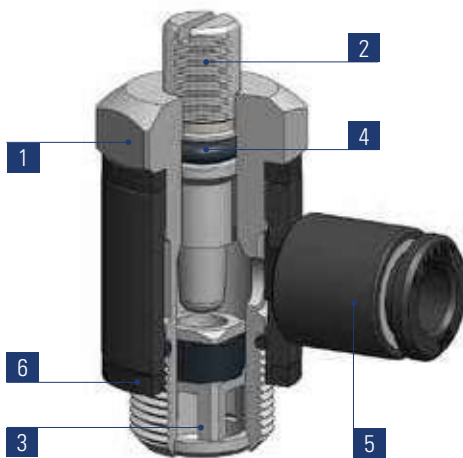

P = 6 bar - Δp = 1 bar

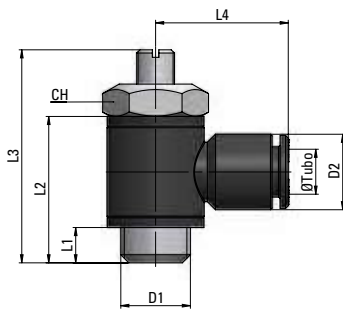
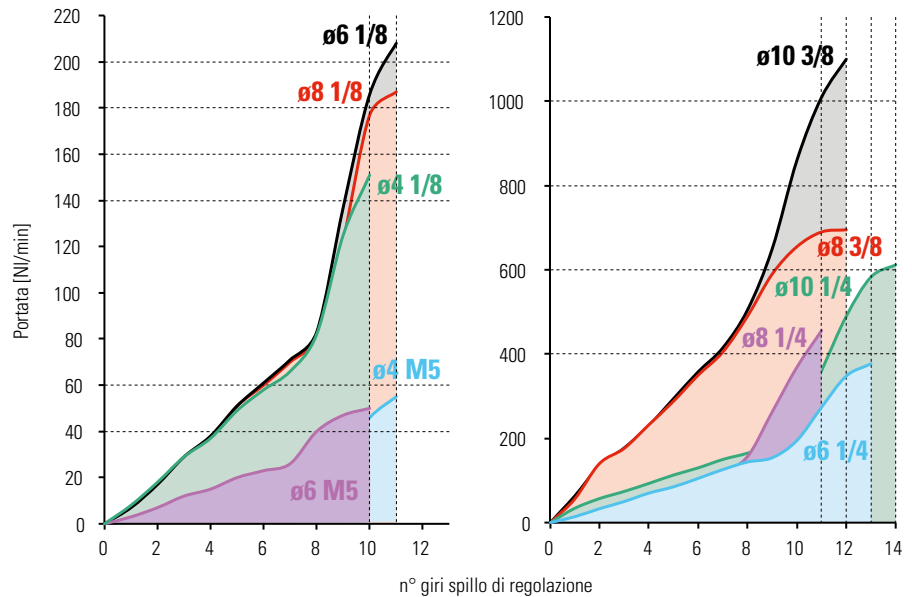

Tipo	Øe Tubo	D1	D2	L1	L2	L3 max	L4	CH	g Δ
39 04 M5	4	M5x0,8	9,7	4	16	25	17	8	7
39 04 18	4	G1/8	9,7	5	24	32	18,5	14	19
39 06 M5	6	M5x0,8	12	4	16	25	20,5	8	8
39 06 18	6	G1/8	12	5	24	32	22	14	22
39 06 14	6	G1/4	12	6,5	27,5	40	23,5	17	38
39 08 18	8	G1/8	14	5	24	32	22,5	14	22
39 08 14	8	G1/4	14	6,5	27,5	40	24	17	38
39 08 38	8	G3/8	14	7	31	50	26	20	67
39 10 14	10	G1/4	16	6,5	27,5	40	26	17	39
39 10 38	10	G3/8	16	7	31	50	28	20	68

Disponibile nelle versioni:

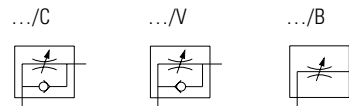

Una volta effettuata l'installazione del regolatore l'anello non è più orientabile.
The banjo ring no longer swivel after flow control installation.
Les banjos ne tournent pas après l'installation du réducteur.
Der Schwenkring bleibt nach der Montage des Drosselrückschlagventiles fest.

SPECIFICHE TECNICHE

Tubi di collegamento consigliati:
PA11, PA12, PA6, Poliuretano PU
(98 Shore A)

Campi di applicazione:
impianti pneumatici alimentati con aria
filtrata e lubrificata.

DATA SHEET

Recommended tubings:
PA11, PA12, PA6, Polyurethane PU
(98 Shore A)

Application field:
pneumatic installations fed with filtered,
lubricated air.

REINSEIGNEMENTS TECHNIQUES

Tube conseillé:
PA11, PA12, PA6, Polyurethane PU
(98 Shore A).

Domaines d'application:
circuits pneumatiques avec air filtré
et lubrifié.

TECHNISCHE AUSKÜNFTE

Empfohlene Schläuche:
PA11, PA12, PA6, Polyurethan PU
(98 Shore A).

Anwendungsbereiche:
pneumatische Anlage mit gefilterter und
geölter Druckluft.

MV 37

Regolatore con raccordo automatico in resina acetalica e pomolo di regolazione

Flow Control with acetal push-in fitting and Handwheel

Réducteur de débit avec raccord automatique en résine acétal et volant moleté

Drosselrückschlagventil mit Steckverschraubung aus Kunststoff und Rändelkopf

1	2	3	4	5	6	7
Corpo Body Corps Körper	Spillo Needle Epingle Nadel	Pomolo Handwheel Volant moleté Rändelkopf	Bussola Cartridge Cartouche Patrone	Guarnizioni Seals Joint d'étanchéité Dichtung	Anello Banjo Ring Banjo Steckverschraubungen	Rondelle Gasket Bague Plastique Kunststoffring
Ottone UNI EN 12164 CW614N Nichelato Brass UNI EN 12164 CW614N Nickel plated Laiton UNI EN 12164 CW614N Nickelé Messing UNI EN 12164 CW614N vernickelt				NBR NBR NBR NBR		PA6 PA6 PA6 PA6

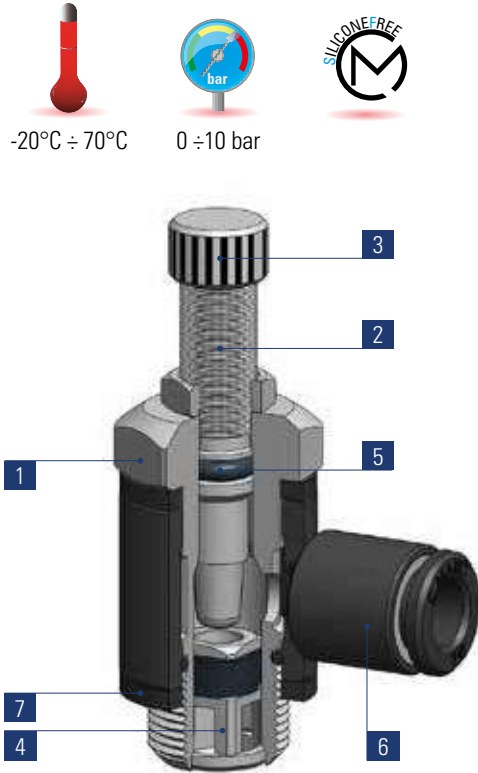

-20°C ÷ 70°C

0 ÷ 10 bar

P = 6 bar - Δp = 1 bar

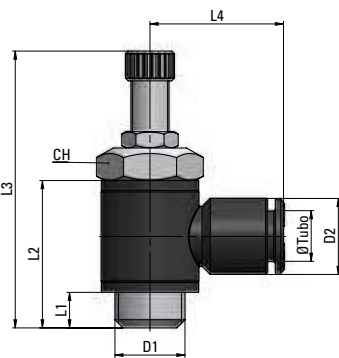
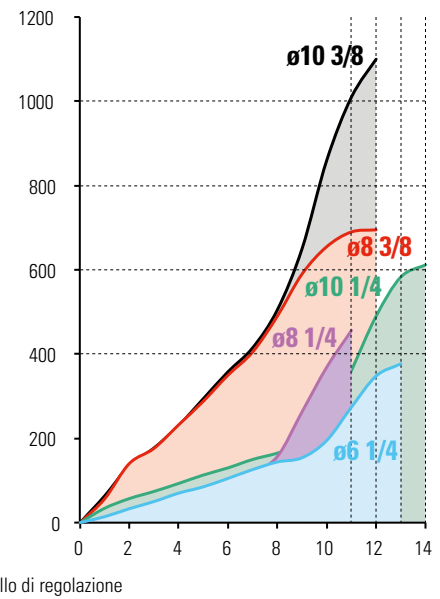
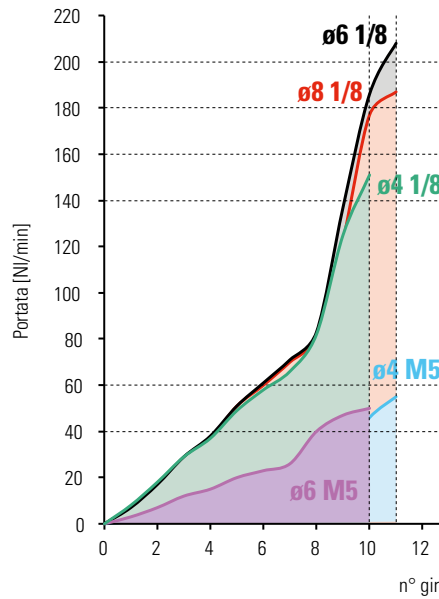

Tipo	Øe Tubo	D1	D2	L1	L2	L3 max	L4	CH	g Δ
37 04 M5	4	M5x0,8	9,7	4	16	38,5	17	8	8
37 04 18	4	G1/8	9,7	5	24	42,5	18,5	14	25
37 06 M5	6	M5x0,8	12	4	16	38,5	20,5	8	9
37 06 18	6	G1/8	12	5	24	42,5	22	14	25
37 06 14	6	G1/4	12	6,5	27,5	51	23,5	17	44
37 08 18	8	G1/8	14	5	24	42,5	22,5	14	25
37 08 14	8	G1/4	14	6,5	27,5	51	24	17	48
37 08 38	8	G3/8	14	7	31	63	26	20	81
37 10 14	10	G1/4	16	6,5	27,5	51	26	17	46
37 10 38	10	G3/8	16	7	31	63	28	20	82

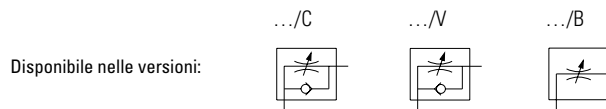

Una volta effettuata l'installazione del regolatore l'anello non è più orientabile.
The banjo ring no longer swivel after flow control installation.
Les banjos ne tournent pas après l'installation du réducteur.
Der Schwenkring bleibt nach der Montage des Drosselrückschlagventiles fest.

SPECIFICHE TECNICHE

Tubi di collegamento consigliati:
PA11, PA12, PA6, Poliuretano PU (98 Shore A)

Campi di applicazione:
impianti pneumatici alimentati con aria filtrata e lubrificata.

DATA SHEET

Recommended tubings:
PA11, PA12, PA6, Polyurethane PU (98 Shore A)

Application field:
pneumatic installations fed with filtered, lubricated air.

REINSEIGNEMENTS TECHNIQUES

Tube conseillé:
PA11, PA12, PA6, Polyurethane PU (98 Shore A)

Domaines d'application:
circuits pneumatiques avec air filtré et lubrifié.

TECHNISCHE AUSKUNFTE

Empfohlene Schläuche:
PA11, PA12, PA6, Polyurethan PU (98 Shore A)

Anwendungsbereiche:
pneumatische Anlage mit gefilterter und geölter Druckluft.

Regolatore con raccordo orientabile automatico in resina acetalica e pomolo di regolazione

Flow Control with Swivelling acetal push-in fitting and Handwheel

Réducteur de débit avec raccord automatique tournant en résine acétal et volant moleté

Drosselrückschlagventil mit schwenkbarer Steckverschraubung aus Kunststoff und Rändelkopf

MV 19

1	2	3	4	5	6
Corpo Body Corps Körper	Spillo Needle Epingle Nadel	Pomolo Handwheel Volant moleté Rändelkopf	Bussola Cartridge Cartouche Patrone	Guarnizioni Seals Joint d'étanchéité Dichtung	Anello Banjo Ring Banjo Steckverschraubungen
Ottone UNI EN 12164 CW614N Nichelato Brass UNI EN 12164 CW614N Nickel plated Laiton UNI EN 12164 CW614N Nickelé Messing UNI EN 12164 CW614N vernickelt				NBR NBR NBR NBR	Raccordo Automatico serie MB MB line push-in fittings Raccords instantanés série MB MB Steckverschraubungen

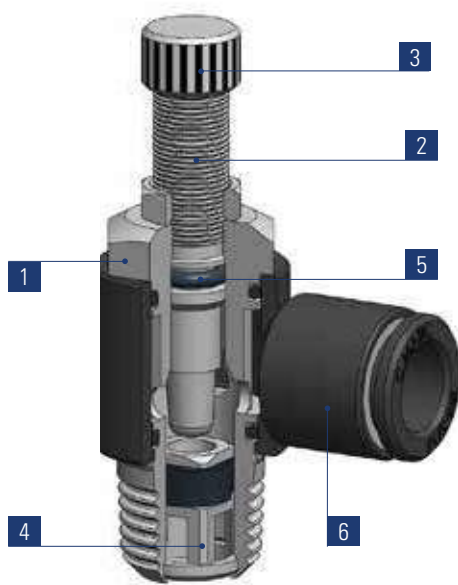

P = 6 bar - Δp = 1 bar

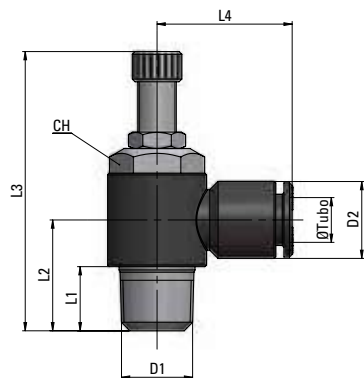
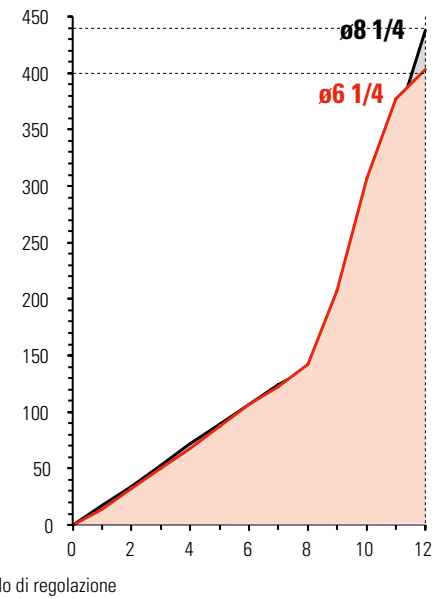
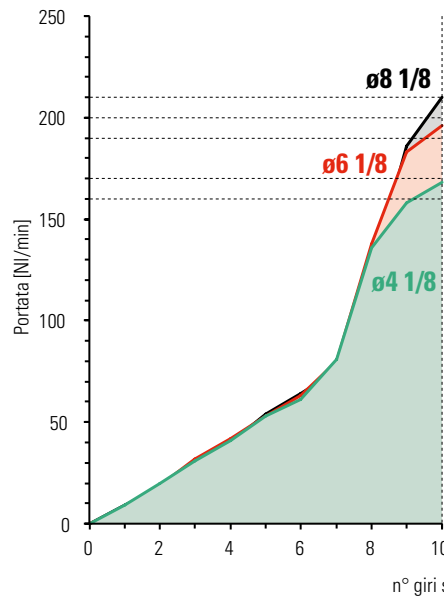

Tipo	Øe Tubo	D1	D2	L1	L2	L3 max	L4	CH	g ΔΔ
19 04 18	4	R1/8	9	9	16	32	19	12	18,95
19 06 18	6	R1/8	12	9	16	32	22,5	12	19,43
19 06 14	6	R1/4	12	12	20	39	24	15	35,15
19 08 18	8	R1/8	14	9	16	32	23	12	19,72
19 08 14	8	R1/4	14	12	20	39	24,5	15	35,50



Disponibile nelle versioni:

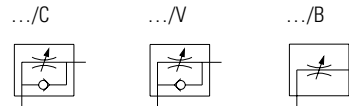

L'anello rimane orientabile anche dopo l'installazione del regolatore.
The banjo ring swivels also after flow control installation.
Les banjos peuvent être orientés après l'installation du réducteur.
Der Schwenkring kann nach der Montage des Drosselrückschlagventiles noch orientiert werden.

SPECIFICHE TECNICHE

Tubi di collegamento consigliati:
PA11, PA12, PA6, Poliuretano PU
(98 Shore A)

Campi di applicazione:
impianti pneumatici alimentati con aria
filtrata e lubrificata.

DATA SHEET

Recommended tubings:
PA11, PA12, PA6, Polyurethane PU
(98 Shore A)

Application field:
pneumatic installations fed with filtered,
lubricated air.

REINSEIGNEMENTS TECHNIQUES

Tube conseillé:
PA11, PA12, PA6, Polyurethane PU
(98 Shore A)

Domaines d'application:
circuits pneumatiques avec air filtré
et lubrifié.

TECHNISCHE AUSKÜNFTE

Empfohlene Schläuche:
PA11, PA12, PA6, Polyurethan PU
(98 Shore A)

Anwendungsbereiche:
pneumatische Anlage mit gefilterter und
geölter Druckluft.

MV 28

Regolatore con raccordo a gomito orientabile

Flow Control with Swivelling outlet

Réducteur de débit avec sortie banjo orientable

Drosselrückschlagventil mit schwenkbarem Ringstückanschluß

1	2	3	4	5
Corpo Body Corps Körper	Spillo Needle Epingle Nadel	Bussola Cartridge Cartouche Patrone	Guarnizioni Seals Joint d'étanchéité Dichtung	Anello Banjo Ring Banjo Steckverschraubungen
Ottone UNI EN 12164 CW614N Nichelato Brass UNI EN 12164 CW614N Nickel plated Laiton UNI EN 12164 CW614N Nickelé Messing UNI EN 12164 CW614N vernickelt			NBR NBR NBR NBR	Raccordo Automatico serie MB MB line push-in fittings Raccords instantanés série MB MB Steckverschraubungen

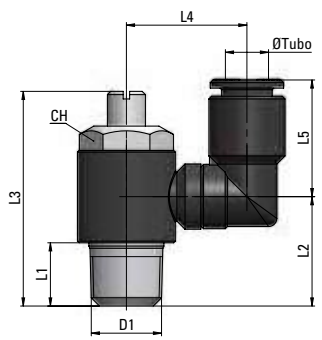
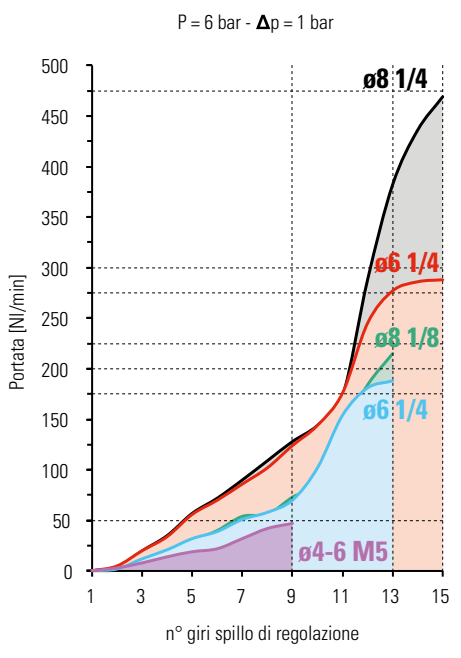
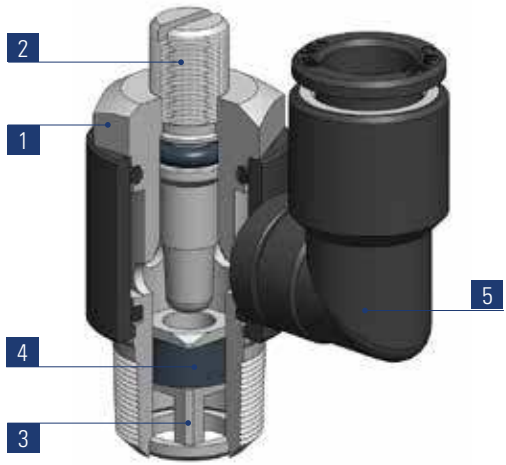
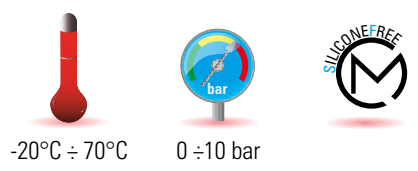

Tipo	Øe Tubo	D1	L1	L2	L3 max	L4	L5	CH	g Δ
28 04 M5	4	M5x0,8	4	9	22	14	15	8	7
28 06 M5	6	M5x0,8	4	9	22	15,5	19	8	10
28 06 18	6	R1/8	9	16	32	19,5	19	12	20
28 06 14	6	R1/4	12	20	39	21	19	15	34
28 08 18	8	R1/8	9	16	32	21	20,5	12	22
28 08 14	8	R1/4	12	20	39	22,5	20,5	15	36

.../C .../V .../B

Disponibile nelle versioni:

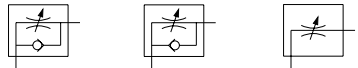

SPECIFICHE TECNICHE

Tubi di collegamento consigliati:
PA11, PA12, PA6, Poliuretano PU (98 Shore A)

Campi di applicazione:
impianti pneumatici alimentati con aria filtrata e lubrificata.

DATA SHEET

Recommended tubings:
PA11, PA12, PA6, Polyurethane PU (98 Shore A)

Application field:
pneumatic installations fed with filtered, lubricated air.

REINSEIGNEMENTS TECHNIQUES

Tube conseillé:
PA11, PA12, PA6, Polyurethane PU (98 Shore A).

Domaines d'application:
circuits pneumatiques avec air filtré et lubrifié.

TECHNISCHE AUSKUNFTE

Empfohlene Schläuche:
PA11, PA12, PA6, Polyurethan PU (98 Shore A).

Anwendungsbereiche:
pneumatische Anlage mit gefilterter und geölter Druckluft.

Regolatore di flusso
per alte portate

Flow control, high flow
capacity

Réducteur de débit, haut
débit

Drosselrückschlagventil,
hohe Druckleistung

MV 29

1	2	3	4	5	6
Corpo Body Corps Körper	Spillo Needle Epingle Nadel	Anello Banjo Ring Banjo Steckverschraubungen	Bussola Cartridge Cartouche Patrone	Guarnizioni Seals Joint d'étanchéité Dichtung	Molle Spring Ressort Feder
Ottone UNI EN 12164 CW614N Nichelato Brass UNI EN 12164 CW614N Nickel plated Laiton UNI EN 12164 CW614N Nickelé Messing UNI EN 12164 CW614N vernickelt		Ottone UNI EN 12165 CW617N Nichelato Brass UNI EN 12165 CW617N Nickel plated Laiton UNI EN 12165 CW617N Nickelé Messing UNI EN 12165 CW617N vernickelt	Ottone UNI EN 12164 CW614N Brass UNI EN 12164 CW614N Laiton UNI EN 12164 CW614N Messing UNI EN 12164 CW614N	NBR NBR NBR NBR	Acciaio Inox AISI 302 Stainless Steel AISI 302 Acier Inox AISI 302 Edelstahl AISI 302

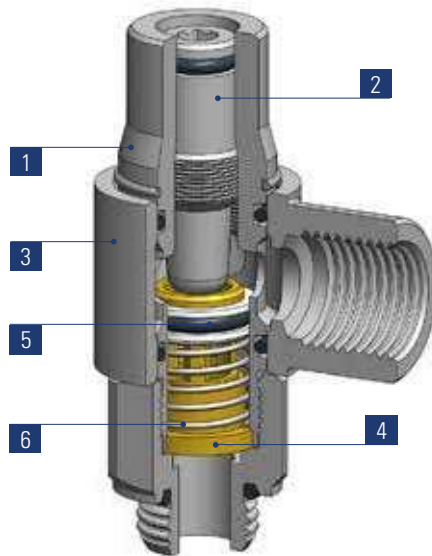

P = 6 bar - $\Delta p = 1$ bar

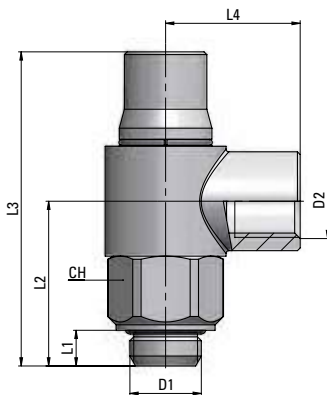
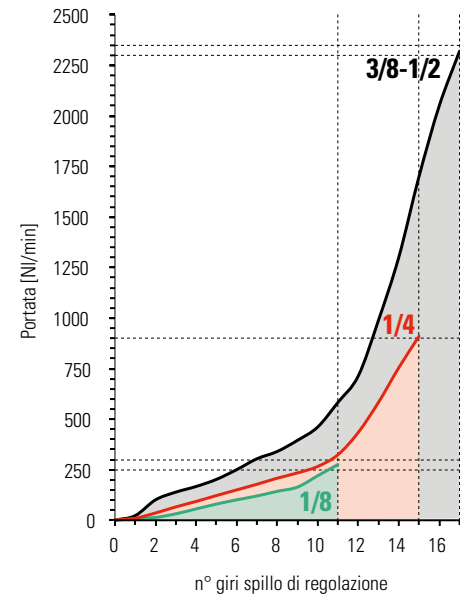

Tipo	D1	D2	L1	L2	L3	L4	CH	g Δ
29 00 18	G1/8	G1/8	6	23	45	20	14	54
29 00 14	G1/4	G1/4	8	30	57	26	19	84
29 00 38	G3/8	G3/8	9	37	67	27	22	163
29 00 12	G1/2	G1/2	10	36	66	31	27	195

.../C

Disponibile nelle versioni:



SPECIFICHE TECNICHE

Tubi di collegamento consigliati:
variabili in funzione del tipo di raccordo collegato al regolatore.

Campi di applicazione:
impianti pneumatici alimentati con aria filtrata e lubrificata.

DATA SHEET

Recommended tubings:
according to the fitting connected to the flow control.

Application field:
pneumatic installations fed with filtered, lubricated air.

REINSEIGNEMENTS TECHNIQUES

Tube conseillé:
en fonction du raccord monté sur le réducteur.

Domaines d'application:
circuits pneumatiques avec air filtré et lubrifié.

TECHNISCHE AUSKÜNFTE

Empfohlene Schläuche:
die Schläuche werden durch die am Drosselrückschlagventil montierte.

Anwendungsbereiche:
pneumatische Anlage mit gefilterter und geölter Druckluft.

MV 21	Regolatore di flusso in linea	In-Line flow control	Réducteur de débit en ligne	Drosselrückschlagventil	
1	2	3	4	5	6
Corpo Body Corps Körper	Regolatore Valve Réducteur de débit Drosselventil	Spillo Needle Epingle Nadel	Pomolo Handwheel Volant moleté Rändelkopf	Dado Nut Ecrou Überwurfmutter	Guarnizioni Seals Joint d'étanchéité Dichtung
Alluminio anodizzato Anodized aluminium Alluminium anodisé Eloxiertes Aluminium	Ottone UNI EN 12164 CW614N Nichelato Brass UNI EN 12164 CW614N Nickel plated Laiton UNI EN 12164 CW614N Nickelé Messing UNI EN 12164 CW614N vernickelt				NBR NBR NBR NBR

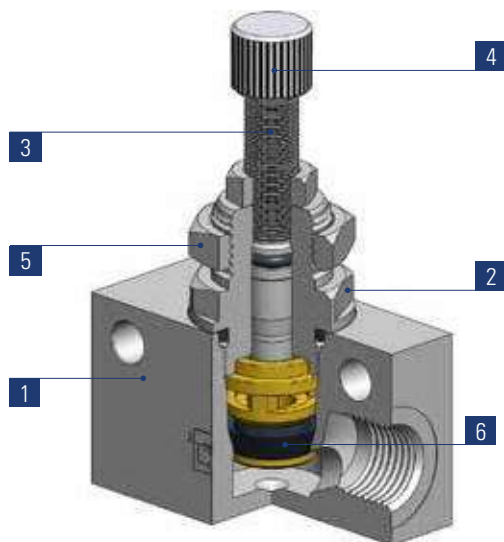

P = 6 bar - Δp = 1 bar

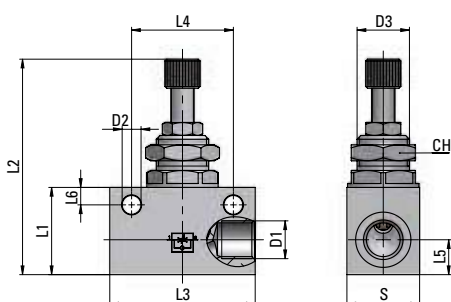
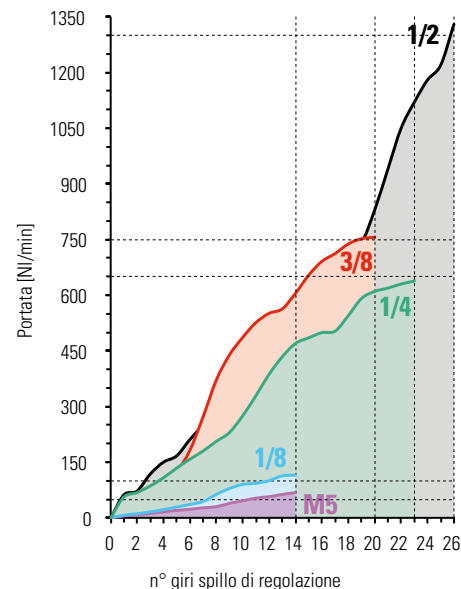

Tipo	D1	D2	D3	L1	L2 max	L3	L4	L5	S	CH	g ΔΔ
21 00 M5	M5x0,8	3,2	M9x0,75	15	37	25	18	7	12	11	19
21 00 18	G1/8	4,5	M12x0,75	21	56	34	24	8	16	15	50
21 00 14	G1/4	6,5	M18x1,5	30	75	50	35	12	25	22	162
21 00 38	G3/8	6,5	M18x1,5	30	75	58	40	12	25	22	169
21 00 12	G1/2	6,5	M22x1,5	40	92	65	50	17	30	26	299

Disponibile nelle versioni:

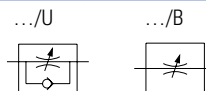

SPECIFICHE TECNICHE

Tubi di collegamento consigliati:
variabili in funzione del tipo di raccordo collegato al regolatore.

Campi di applicazione:
impianti pneumatici alimentati con aria filtrata e lubrificata.

DATA SHEET

Recommended tubings:
according to the fitting connected to the flow control.

Application field:
pneumatic installations fed with filtered, lubricated air.

REINSEIGNEMENTS TECHNIQUES

Tube conseillé:
en fonction du raccord monté sur le réducteur.

Domaines d'application:
circuits pneumatiques avec air filtré et lubrifié.

TECHNISCHE AUSKUNFTE

Empfohlene Schläuche:
die Schläuche werden durch die am Drosselrückschlagventil montierte.

Anwendungsbereiche:
pneumatische Anlage mit gefilterter und geölter Druckluft.

Regolatore di flusso con corpo in resina acetalica

Acetal In-Line Flow Control

Réducteur de débit avec corps résine acetal

Kunststoff Drosselrückschlagventil

MV 34

1	2	3	4	5	6
Corpo Body Corps Körper	Regolatore Valve Réducteur de débit Drosselventil	Spillo Needle Epingle Nadel	Pomolo Handwheel Volant moleté Rändelkopf	Guarnizioni Seals Joint d'étanchéité Dichtung	Raccordi Fittings Raccords Steckverschraubungen
POM POM POM POM	Ottone UNI EN 12164 CW614N Nichelato Brass UNI EN 12164 CW614N Nickel plated Laiton UNI EN 12164 CW614N Nickelé Messing UNI EN 12164 CW614N vernickelt			NBR NBR NBR NBR	Raccordo Automatico serie MB MB line push-in fittings Raccords instantanés série MB MB Steckverschraubungen

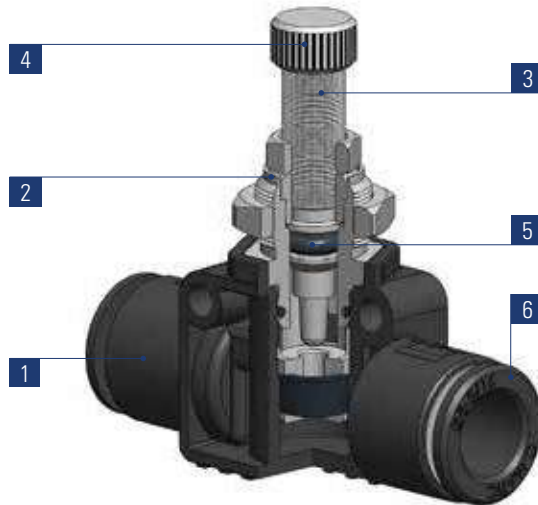

P = 6 bar - Δp = 1 bar

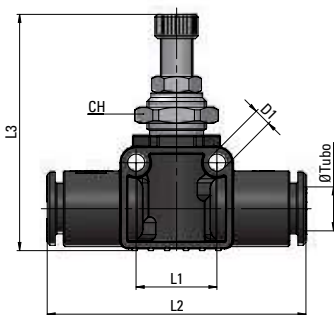
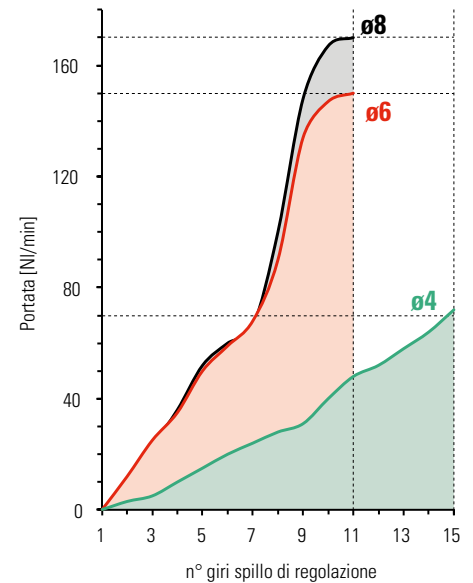

Tipo	Øe Tubo	D1	L1	L2	L3 max	CH	g
34 04 04	4	3,2	13	36	35	11	14
34 06 06	6	3,2	16	45	45	14	26
34 08 08	8	3,2	16	46	46	14	28

Disponibile nelle versioni:

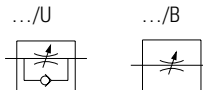

SPECIFICHE TECNICHE

Tubi di collegamento consigliati:
PA11, PA12, PA6, Poliuretano PU (98 Shore A)

Campi di applicazione:
impianti pneumatici alimentati con aria filtrata e lubrificata.

DATA SHEET

Recommended tubings:
PA11, PA12, PA6, Polyurethane PU (98 Shore A)

Application field:
pneumatic installations fed with filtered, lubricated air.

REINSEIGNEMENTS TECHNIQUES

Tube conseillé:
PA11, PA12, PA6, Polyurethane PU (98 Shore A).

Domaines d'application:
circuits pneumatiques avec air filtré et lubrifié.

TECHNISCHE AUSKÜNFTE

Empfohlene Schläuche:
PA11, PA12, PA6, Polyurethan PU (98 Shore A).

Anwendungsbereiche:
pneumatische Anlage mit gefilterter und geölter Druckluft.

MV 35	Regolatore di flusso con corpo in resina acetilica			Acetal Line Flow Control		Réducteur de débit avec corps résine acetal		Kunststoff Drosselrückschlagventil	
1	2	3	4	5	6	6	7	7	7
Corpo Body Corps Körper	Regolatore Valve Réducteur de débit Drosselventil	Spillo Needle Epingle Nadel	Pomolo Handwheel Volant moleté Rändelkopf	Guarnizioni Seals Joint d'étanchéité Dichtung	Filetto Thread Filetage Gewinde		Raccordi Fittings Raccords Steckverschraubungen		
POM POM POM POM	Ottone UNI EN 12164 CW614N Nichelato Brass UNI EN 12164 CW614N Nickel plated Laiton UNI EN 12164 CW614N Nickelé Messing UNI EN 12164 CW614N vernickelt			NBR NBR NBR NBR		Ottone UNI EN 12164 CW614N Nichelato Brass UNI EN 12164 CW614N Nickel plated Laiton UNI EN 12164 CW614N Nickelé Messing UNI EN 12164 CW614N vernickelt	Raccordo Automatico serie MB MB line push-in fittings Raccords instantanés série MB MB Steckverschraubungen		



P = 6 bar - Δp = 1 bar

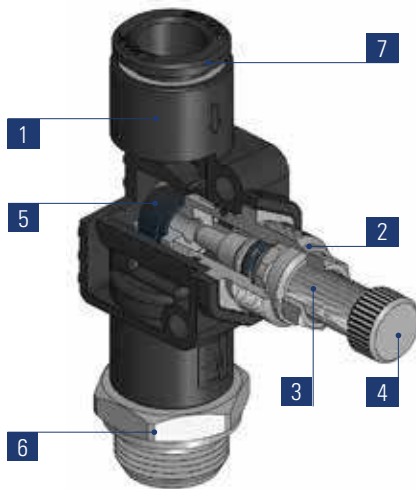
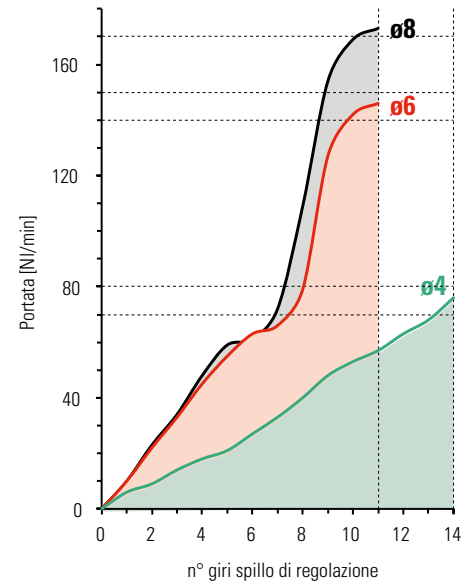

Tipo	Øe Tubo	D1	D2	L1	L2	L3	L4 max	CH	g Δ
35 04 M5	4	M5x0,8	3,2	4	43	13	35	9	17,5
35 04 18	4	G1/8	3,2	5	43	13	35	13	18
35 06 18	6	G1/8	3,2	5	52	16	45	13	32
35 06 14	6	G1/4	3,2	6,5	54	16	45	16	35
35 08 18	8	G1/8	3,2	5	53	16	46	14	35
35 08 14	8	G1/4	3,2	6,5	55	16	46	16	37

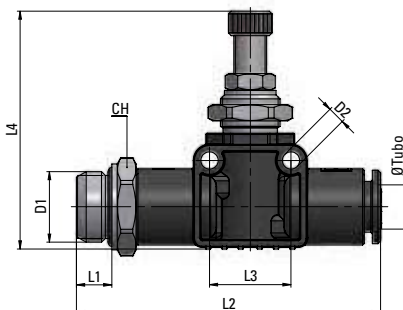

Disponibile nelle versioni:

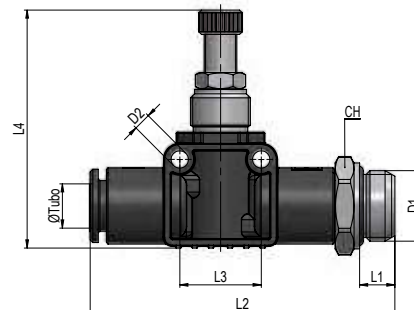
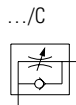

Disponibile nelle versioni:

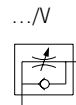

SPECIFICHE TECNICHE

Tubi di collegamento consigliati:
PA11, PA12, PA6, Poliuretano PU
(98 Shore A)

Campi di applicazione:
impianti pneumatici alimentati con aria
filtrata e lubrificata.

DATA SHEET

Recommended tubings:
PA11, PA12, PA6, Polyurethane PU
(98 Shore A)

Application field:
pneumatic installations fed with filtered,
lubricated air.

REINSEIGNEMENTS TECHNIQUES

Tube conseillé:
PA11, PA12, PA6, Polyurethane PU
(98 Shore A).

Domaines d'application:
circuits pneumatiques avec air filtré
et lubrifié.

TECHNISCHE AUSKUNFTE

Empfohlene Schläuche:
PA11, PA12, PA6, Polyurethan PU
(98 Shore A).

Anwendungsbereiche:
pneumatische Anlage mit gefilterter und
geölter Druckluft.

Regolatore di Flusso
con codulo

Plug-in flow control

Réducteur de débit à
broche encliquetable

Drosselrückschlagventil
mit Steckzapfen

MV 43

1	2	3	4	5
Corpo Body Corps Körper	Pomolo Handwheel Volant moleté Rändelkopf	Spillo Needle Epingle Nadel	Guarnizioni Seals Joint d'étanchéité Dichtung	Anello Banjo Ring Banjo Steckverschraubungen
Ottone UNI EN 12164 CW614N Nichelato Brass UNI EN 12164 CW614N Nickel plated Laiton UNI EN 12164 CW614N Nickelé Messing UNI EN 12164 CW614N vernickelt			NBR NBR NBR NBR	Raccordo Automatico serie MB MB line push-in fittings Raccords instantanés série MB MB Steckverschraubungen

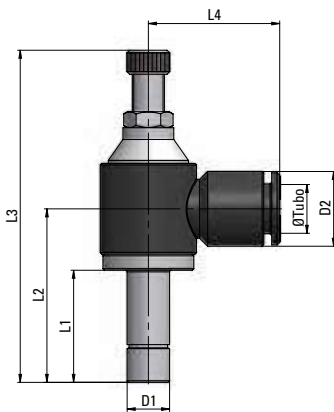
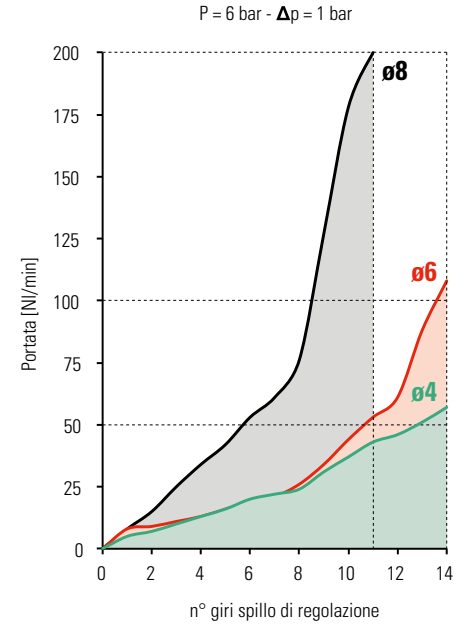
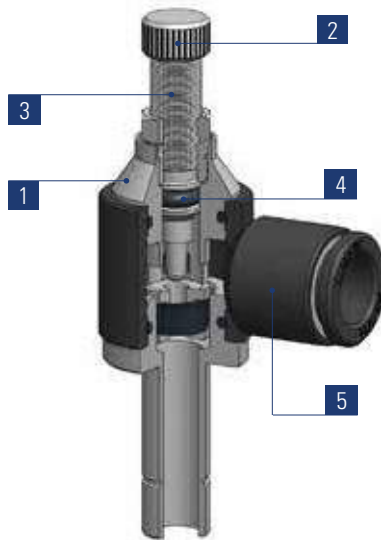

Tipo	Øe Tubo	D1	D2	L1	L2	L3 max	L4	g Δ
43 04 04	4	4	9,7	16	29,5	57,5	17	12
43 06 06	6	6	12	20	29,5	55,5	22	18
43 08 08	8	8	14	20	31,5	63,5	24	35

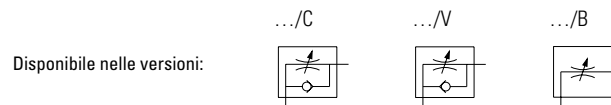

SPECIFICHE TECNICHE

Tubi di collegamento consigliati:
PA11, PA12, PA6, Poliuretano PU
(98 Shore A)

Campi di applicazione:
impianti pneumatici alimentati con aria
filtrata e lubrificata.

DATA SHEET

Recommended tubings:
PA11, PA12, PA6, Polyurethane PU
(98 Shore A)

Application field:
pneumatic installations fed with filtered,
lubricated air.

REINSEIGNEMENTS TECHNIQUES

Tube conseillé:
PA11, PA12, PA6, Polyurethane PU
(98 Shore A)

Domaines d'application:
circuits pneumatiques avec air filtré
et lubrifié.

TECHNISCHE AUSKÜNFTE

Empfohlene Schläuche:
PA11, PA12, PA6, Polyurethan PU
(98 Shore A)

Anwendungsbereiche:
pneumatische Anlage mit gefilterter und
geölter Druckluft.

MV 49	Regolatore di flusso ad anello	Banjo with integrated flow control	Banjo avec limiteur de débit intégré	Schwenkring mit integriertem Rückschlagventil
1	2	3	4	
Corpo Body Corps Körper	Spillo Needle Epingle Nadel	Guarnizioni Seals Joint d'étanchéité Dichtung		Raccordo Automatico Push-in fittings Raccords instantanés Steckverschraubungen
Ottone UNI EN 12164 CW614N Nichelato Brass UNI EN 12164 CW614N Nickel plated Laiton UNI EN 12164 CW614N Nickelé Messing UNI EN 12164 CW614N vernickelt		NBR NBR NBR NBR		Raccordo Automatico serie MA MA line push-in fittings Raccords instantanés série MA MA Steckverschraubungen

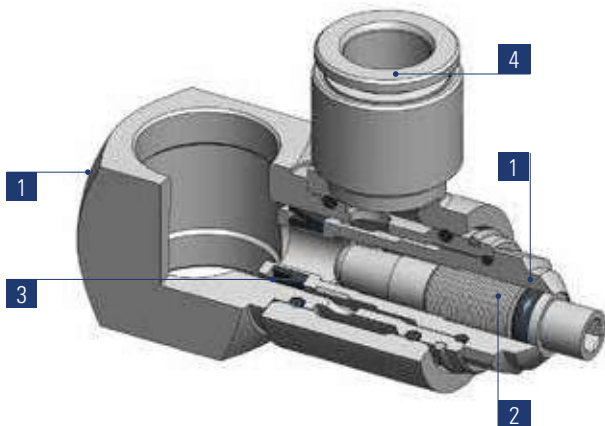

Controlled Pneumatic Switch



Controlled Stop Valve

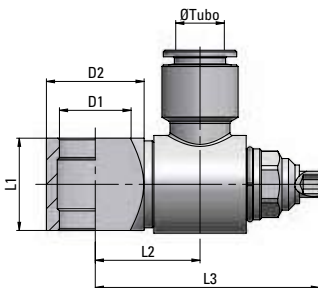

Tipo	Øe Tubo	D1	D2	L1	L2	L3 max	g ΔΔ
49 06 14	6	1/4	18	17	17,5	41	63,5
49 08 14	8	1/4	18	17	17,5	41	64
49 08 38	8	3/8	21	20	21	49	101
49 10 38	10	3/8	21	20	21	49	104

Disponibile nelle versioni:

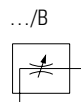
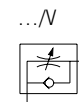
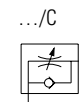

SPECIFICHE TECNICHE

Tubi di collegamento consigliati:
PA11, PA12, PA6, Poliuretano PU
(98 Shore A)

Campi di applicazione:
impianti pneumatici alimentati con aria
filtrata e lubrificata.

DATA SHEET

Recommended tubings:
PA11, PA12, PA6, Polyurethane PU
(98 Shore A)

Application field:
pneumatic installations fed with filtered,
lubricated air.

REINSEIGNEMENTS TECHNIQUES

Tube conseillé:
PA11, PA12, PA6, Polyurethane PU
(98 Shore A).

Domaines d'application:
circuits pneumatiques avec air filtré
et lubrifié.

TECHNISCHE AUSKUNFTE

Empfohlene Schläuche:
PA11, PA12, PA6, Polyurethan PU
(98 Shore A).

Anwendungsbereiche:
pneumatische Anlage mit gefilterter und
geölter Druckluft.

1	2	3	4
Corpo Body Corps Körper	Otturatore Valve Clapet Ventil	Guarnizioni Seals Joint d'étanchéité Dichtung	Molla Spring Ressort Feder
Ottone UNI EN 12164 CW614N Nichelato Brass UNI EN 12164 CW614N Nickel plated Laiton UNI EN 12164 CW614N Nickelé Messing UNI EN 12164 CW614N vernickelt		NBR NBR NBR NBR	Acciaio Inox AISI 302 Stainless Steel AISI 302 Acier Inox AISI 302 Edelstahl AISI 302

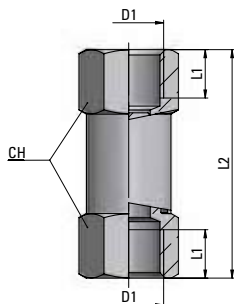
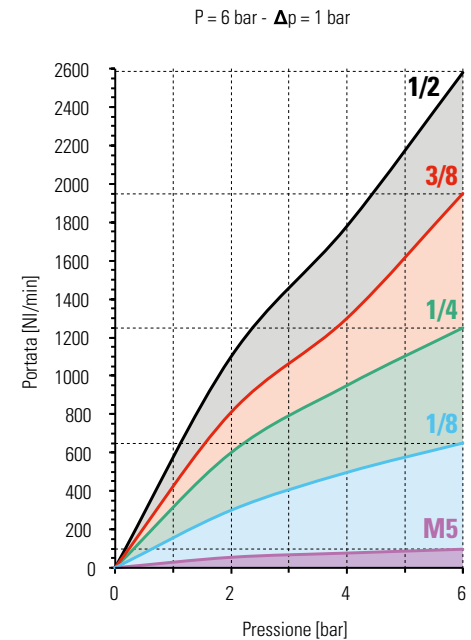
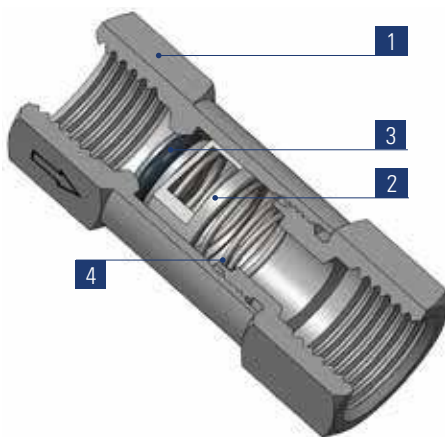
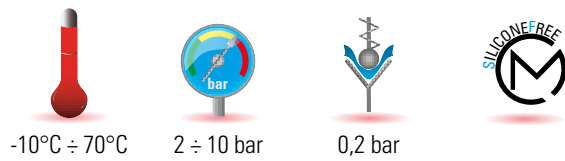

Tipo	D1	L1	L2	CH	g $\Delta\Delta$
23 00 M5	M5x0,8	5	25	8	8
23 00 18	G1/8	8	36,5	13	26
23 00 14	G1/4	9	42,5	16	38
23 00 38	G3/8	10,5	51	20	72
23 00 12	G1/2	12,5	62	24	119

Queste valvole permettono il passaggio dell'aria in un unico senso (indicato sul corpo della valvola da una freccia) impedendolo in senso contrario.

The flow is allowed only in one way (the arrow direction engraved on the body) and stopped in the reverse way.

Il permet le passage du débit dans un seul sens (celui marqué sur le corps de la vanne par une flèche) tout en empêchant son retour dans le sens contraire.

Der Durchfluss wird nur einseitig erlaubt. Im Allgemeinen ist es die Richtung entsprechend dem auf dem Rückschlagventilskörper gekennzeichneten Pfeil. Die andere Seite bleibt abgesperrt.

SPECIFICHE TECNICHE

Tubi di collegamento consigliati:
variabili in funzione del tipo di raccordo collegato alla valvola.

DATA SHEET

Recommended tubings:
according to the fitting connected to the valve.

REINSEIGNEMENTS TECHNIQUES

Tube conseillé:
en fonction du raccord monté sur la vanne.

TECHNISCHE AUSKÜNFTE

Empfohlene Schläuche:
Die Schläuche werden durch die am Schnelllüftungsventil montierte Verschraubung bestimmt.

Campi di applicazione:
impianti pneumatici alimentati con aria filtrata e lubrificata.

Application field:
pneumatic installations fed with filtered, lubricated air.

Domaines d'application:
circuits pneumatiques avec air filtré et lubrifié.

Anwendungsbereiche:
pneumatische Anlage mit gefilterter und geölter Druckluft.

MV 33		Raccordo diritto con valvola di non ritorno	Straight connection with check valve	Union simple avec clapet anti-retour	Gerade Verschraubung mit Rückschlagventil
1	2	3	4	5	
Corpo Body Corps Körper	Otturatore Valve Clapet Ventil	Guarnizioni Seals Joint d'étanchéité Dichtung	Molla Spring Ressort Feder	Raccordo Automatico Push-in fittings Raccords instantanés Steckverschraubungen	
Ottone UNI EN 12164 CW614N Nichelato Brass UNI EN 12164 CW614N Nickel plated Laiton UNI EN 12164 CW614N Nickelé Messing UNI EN 12164 CW614N vernickelt		NBR NBR NBR NBR	Acciaio Inox AISI 302 Stainless Steel AISI 302 Acier Inox AISI 302 Edelstahl AISI 302	Raccordo Automatico serie MA MA line push-in fittings Raccords instantanés série MA MA Steckverschraubungen	

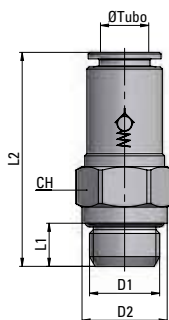
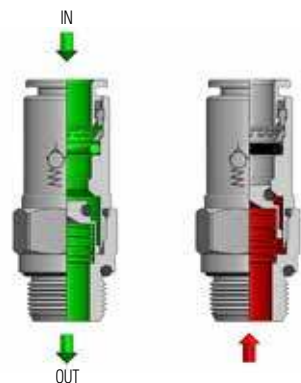
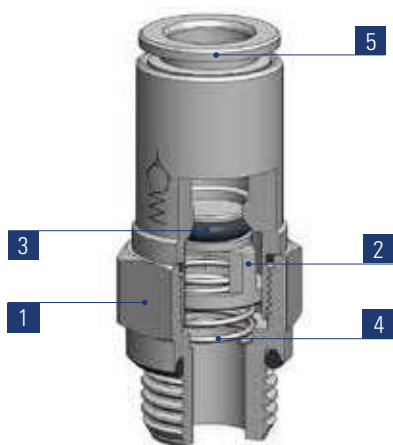
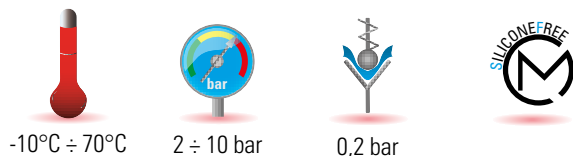

Tipo	Øe Tubo	D1	D2	L1	L2	CH	g ΔΔ
33 04 M5	4	M5x0,8	8	4	37,5	9	11
33 04 18	4	G1/8	13	6	31	11	14
33 06 18	6	G1/8	13	6	38	13	21
33 06 14	6	G1/4	16	8	39	14	27
33 08 18	8	G1/8	13	6	39	15	25
33 08 14	8	G1/4	16	8	40	16	30
33 10 14	10	G1/4	16	8	43	18	37
33 10 38	10	G3/8	20	9	43	18	43
33 12 12	12	G1/2	25	10	47	22	68
33 14 12	14	G1/2	25	10	54	25	85

Queste valvole permettono il passaggio dell'aria in un unico senso (indicato sul corpo della valvola da una freccia) impedendolo in senso contrario.

The flow is allowed only in one way (the arrow direction engraved on the body) and stopped in the reverse way.

Il permet le passage du débit dans un seul sens (celui marqué sur le corps de la vanne par une flèche) tout en empêchant son retour dans le sens contraire.

Der Durchfluss wird nur einseitig erlaubt. Im Allgemeinen ist es die Richtung entsprechend dem auf dem Rückschlagventilkörper gekennzeichneten Pfeil. Die andere Seite bleibt abgesperrt.

SPECIFICHE TECNICHE

Tubi di collegamento consigliati:
PA11, PA12, PA6, Poliuretano PU (98 Shore A)

Campi di applicazione:
impianti pneumatici alimentati con aria filtrata e lubrificata.

DATA SHEET

Recommended tubings:
PA11, PA12, PA6, Polyurethane PU (98 Shore A)

Application field:
pneumatic installations fed with filtered, lubricated air.

REINSEIGNEMENTS TECHNIQUES

Tube conseillé:
PA11, PA12, PA6, Polyurethane PU (98 Shore A)

Domaines d'application:
circuits pneumatiques avec air filtré et lubrifié.

TECHNISCHE AUSKUNFTE

Empfohlene Schläuche:
PA11, PA12, PA6, Polyurethan PU (98 Shore A)

Anwendungsbereiche:
pneumatische Anlage mit gefilterter und geölter Druckluft.

Valvola di scarico rapido in linea

Line Quick Exhaust valve

Clapet anti-retour

Schnellentlüftungsventil in Linie

MV 22

1	2	3	4	5
Corpo Body Corps Körper	Guarnizione a labbro Lip ring Joint à lèvres Lippendichtung	Guarnizioni Seals Joint d'étanchéité Dichtung	Silenziatore Muffler Silencieux Schalldämpfer	Seeger
Alluminio Anodizzato Anodised Aluminium Aluminium Anodisé Eloxiertes Aluminium	PU - NBR solo per 1/4 PU - NBR only for 1/4 PU - NBR seulement pour 1/4 PU - NBR nur bei 1/4	NBR NBR NBR NBR	Acciaio Inox AISI 316 Stainless Steel AISI 316 Acier Inox AISI 316 Edelstahl AISI 316	Acciaio C75 Zincato C75 Steel zinc coated Acier C75 zingué C75 Stahl verzinkt

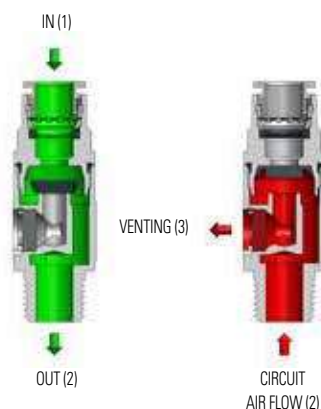
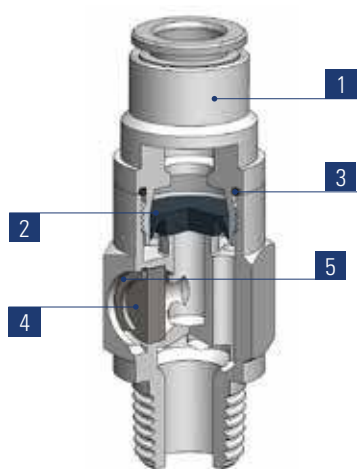

Portata a 6 bar
Flow rate at 6 bar
Débit à 6 bar
Druckfluß (6 bar)

IN OUT
1→2

OUT VENT
2→3

1/4	1050 NI/min	660 NI/min
3/8	3000 NI/min	1900 NI/min
1/2	3420 NI/min	2280 NI/min

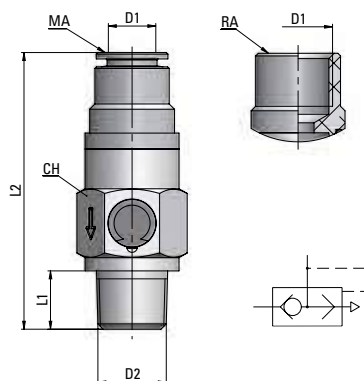

Tipo	D1	D2	L1	L2	CH	g $\Delta\Delta$
22 08 14 -MA	R1/4	8	11	51	18	18,2
22 14 14 -RA	R1/4	G1/4	11	49	18	17,5
22 10 38 -MA	R3/8	10	11,5	63	27	47
22 38 38 -RA	R3/8	G3/8	11,5	56	27	47,5
22 12 12 -MA	R1/2	12	14	73	34	84
22 12 12 -RA	R1/2	G1/2	14	70	34	87,5

Valvola in grado di scaricare rapidamente l'aria contenuta in un circuito in caso di mancanza d'alimentazione; se applicate ad un cilindro permettono di aumentarne la velocità.

This valve can easily vent the circuit in case of an air supply failure. If assembled on the cylinder port, it increases the cylinder speed.

Cette vanne permet de mettre à l'échappement un circuit en cas de défaut d'alimentation. Raccordée sur un vérin, elle permet d'augmenter la vitesse du débit d'échappement et de ce fait d'augmenter sa vitesse de fonctionnement.

Dieses Ventil kann bei Luftmangel die Anlage schnell entlüften. Wenn am Zylinderanschluss montiert, wird dessen Geschwindigkeit vergrößert.

SPECIFICHE TECNICHE

Tubi di collegamento consigliati:
PA11, PA12, PA6, Poliuretano PU
(98 Shore A)

Campi di applicazione:
impianti pneumatici alimentati con aria filtrata e lubrificata.

DATA SHEET

Recommended tubings:
PA11, PA12, PA6, Polyurethane PU
(98 Shore A)

Application field:
pneumatic installations fed with filtered, lubricated air.

REINSEIGNEMENTS TECHNIQUES

Tube conseillé:
PA11, PA12, PA6, Polyurethane PU
(98 Shore A).

Domaines d'application:
circuits pneumatiques avec air filtré et lubrifié.

TECHNISCHE AUSKÜNFTE

Empfohlene Schläuche:
PA11, PA12, PA6, Polyurethan PU
(98 Shore A).

Anwendungsbereiche:
pneumatische Anlage mit gefilterter und geölter Druckluft.

MV 27	Valvola di scarico rapido	Quick exhaust valve	Vanne à échappement rapide	Schnellentlüftungsventil
1	2	3	3	3
Corpo Body Corps Körper	Guarnizione a labbro Lip ring Joint à lèvres Lippendichtung	Rondelle Gasket Bague Plastique Kunststoffring		
Ottone UNI EN 12165 CW617N Nichelato Brass UNI EN 12165 CW617N Nickel plated Laiton UNI EN 12165 CW617N Nickelé Messing UNI EN 12165 CW617N vernickelt	PU - NBR solo per M5 PU - NBR only for M5 PU - NBR seulement pour M5 PU - NBR nur bei M5	PA6 PA6 PA6 PA6		

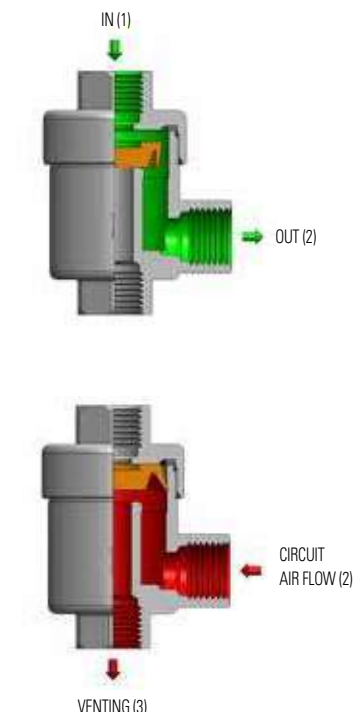
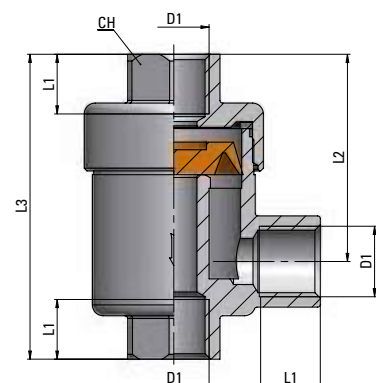
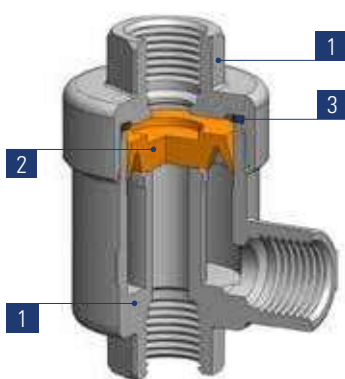

Portata Flow rate Débit Druckfluß	(6 bar - Δp = 1bar)	
	IN OUT 1→2	OUT VENT 2→3
M5	133 NI/min	150 NI/min
1/8	450 NI/min	760 NI/min
1/4	780 NI/min	1840 NI/min
3/8	1160 NI/min	2600 NI/min
1/2	1260 NI/min	5300 NI/min
3/4 (3 bar)	1530 NI/min	3300 NI/min

*Portata a 3 bar - Flow rate at 3 bar
Débit à 3 bar - Druckfluß (3 bar)

Tipo	D1	L1	L2	L3	CH	g Δ
27 00 M5	M5x0,8	5	17	25	10	32
27 00 18	G1/8	7,5	27	42	15	85
27 00 14	G1/4	11	35	54	19	156
27 00 38	G3/8	12	35	55	21	164
27 00 12	G1/2	14	45	72	26	313
27 00 34	G3/4	16	53	89	32	505

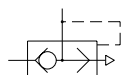

Valvola in grado di scaricare rapidamente l'aria contenuta in un circuito in caso di mancanza d'alimentazione; se applicate ad un cilindro permettono di aumentarne la velocità.

This valve can easily vent the circuit in case of an air supply failure. If assembled on the cylinder port, it increases the cylinder speed.

Cette vanne permet de mettre à l'échappement un circuit en cas de défaut d'alimentation. Raccordée sur un vérin, elle permet d'augmenter la vitesse du débit d'échappement et de ce fait d'augmenter sa vitesse de fonctionnement.

Dieses Ventil kann bei Luftmangel die Anlage schnell entlüften. Wenn am Zylinderanschluss montiert, wird dessen Geschwindigkeit vergrößert.

SPECIFICHE TECNICHE

Tubi di collegamento consigliati: variabili in funzione del tipo di raccordo collegato alla valvola.

DATA SHEET

Recommended tubings: according to the fitting connected to the valve.

REINSEIGNEMENTS TECHNIQUES

Tube conseillé: en fonction du raccord monté sur la vanne.

TECHNISCHE AUSKUNFTE

Empfohlene Schläuche: Die Schläuche werden durch die am Schnellentlüftungsventil montierte Verschraubung bestimmt.

Campi di applicazione: impianti pneumatici alimentati con aria filtrata e lubrificata.

Application field: pneumatic installations fed with filtered, lubricated air.

Domaines d'application: circuits pneumatiques avec air filtré et lubrifié.

Anwendungsbereiche: pneumatische Anlage mit gefilterter und geölter Druckluft.

1	2	3
Corpo Body Corps Körper	Manicotto Sleeve Douille Hülse	Guarnizioni Seals Joint d'étanchéité Dichtung
Ottone UNI EN 12164 CW614N Cromato Brass UNI EN 12164 CW614N Chrome plated Laiton UNI EN 12164 CW614N chromé Ms Verchromt UNI EN 12164 CW614N	Alluminio Anodizzato Anodised Aluminium Aluminium Anodisé Eloxiertes Aluminium	NBR NBR NBR NBR

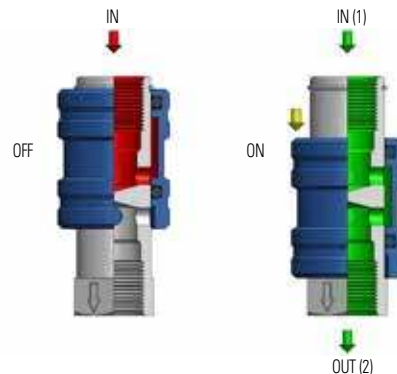
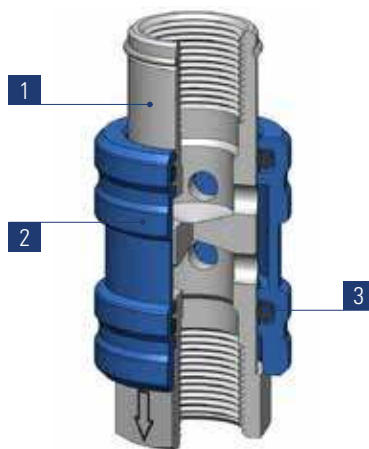

Portata Flow rate Débit Druckfluß	(6 bar - Δp = 1bar)	IN OUT 1 → 2
MV 26 00 M5		125 NI/min
MV 26 00 18		620 NI/min
MV 26 00 14		920 NI/min
MV 26 00 38		1520 NI/min
MV 26 00 12		2720 NI/min

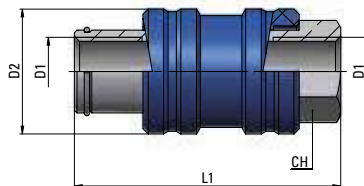

Tipo	D1	D2	L1	CH	g ΔΔ
26 00 M5	M5x0,8	13	30,5	9	10,3
26 00 18	G1/8	21	46	14	40
26 00 14	G1/4	24	51,5	17	57,7
26 00 38	G3/8	31	59	22	117,2
26 00 12	G1/2	35	72,5	26	175,5

Queste valvole hanno lo scopo di sezionare un impianto. Facendo scorrere la ghiera anodizzata si ottengono i due stati possibili (ON-OFF) del circuito. Quando la ghiera è in battuta sull'esagono dello stelo, l'aria fluisce nella direzione indicata dalla freccia stampigliata (ON); facendo retrocedere la ghiera si toglie alimentazione mandando in scarico il circuito (OFF).

The valve is used to section a pneumatic installation. Sliding the sleeve on the rod, both ON and OFF positions can be achieved. When the sleeve is against the rod hexagon, the flow goes in the arrow direction (ON); pushing it backwards the air supply is cut off and the installation is vented (OFF)

La fonction de ces vannes est de sélectionner une installation. En faisant coulisser la douille anodisée, on sélectionne la position ON ou la position OFF du circuit. Si la douille se trouve au niveau du six-pans, le débit passe dans le sens indiqué par la flèche (ON); en faisant coulisser la douille, on coupe l'alimentation et l'air échappe du circuit (OFF)

Der Zweck dieses Ventiles ist die Anlage vom Druckluftnetz zu trennen. Schiebt man die eloxierte Hülse, wird die Anlage ein- bzw. ausgeschaltet. Steht die Schieberhülse in Pfeilrichtung am Spindelsechskant, fließt die Luft entsprechend der geprägten Pfeilrichtung (EIN). Beim Zurückschieben der Hülse wird der Lufteingang gesperrt, und die Anlage entlüftet entgegen der Pfeilrichtung (AUS)

SPECIFICHE TECNICHE

Tubi di collegamento consigliati:
variabili in funzione del tipo di raccordo collegato alla valvola.

Campi di applicazione:
impianti pneumatici alimentati con aria filtrata e lubrificata.

DATA SHEET

Recommended tubings:
according to the fitting connected to the valve.

Application field:
pneumatic installations fed with filtered, lubricated air.

REINSEIGNEMENTS TECHNIQUES

Tube conseillé:
en fonction du raccord monté sur la vanne.

Domaines d'application:
circuits pneumatiques avec air filtré et lubrifié.

TECHNISCHE AUSKÜNFTE

Empfohlene Schläuche:
Die Schläuche werden durch die am Schnelllüftungsventil montierte Verschraubung bestimmt.

Anwendungsbereiche:
pneumatische Anlage mit gefilterter und geölter Druckluft.

MV 32		Valvola selettiva	Shuttle valve	Sélecteur de circuit	Oder-Ventil
1	2	3	4		
Corpo Body Corps Körper	Bussola Cartridge Cartouche Patrone	Guarnizioni Seals Joint d'étanchéité Dichtung	Sfera Ball Bille Kugel		
Alluminio Anodizzato Anodised Aluminium Aluminium Anodisé Eloxiertes Aluminium	Ottone UNI EN 12164 CW614N Brass UNI EN 12164 CW614N Laiton UNI EN 12164 CW614N Messing UNI EN 12164 CW614N	NBR NBR NBR NBR	Acciaio Inox AISI 420 Stainless Steel AISI 420 Acier Inox AISI 420 Edelstahl AISI 420		

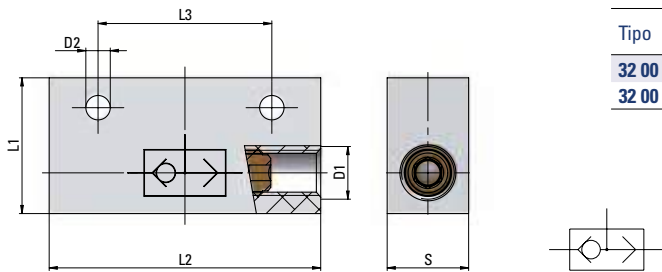
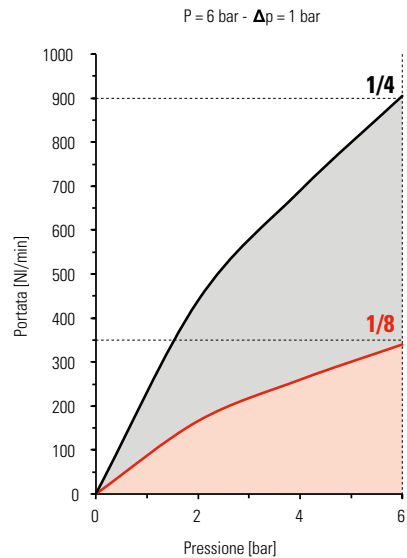
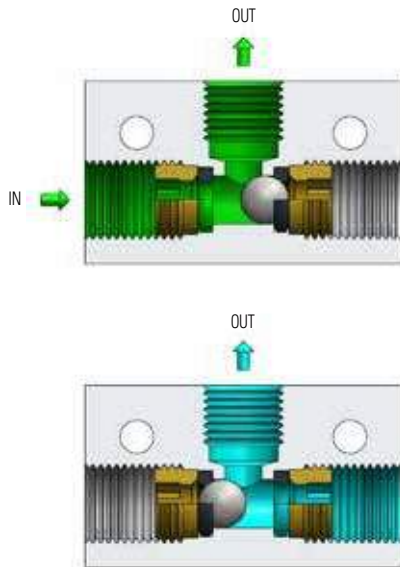
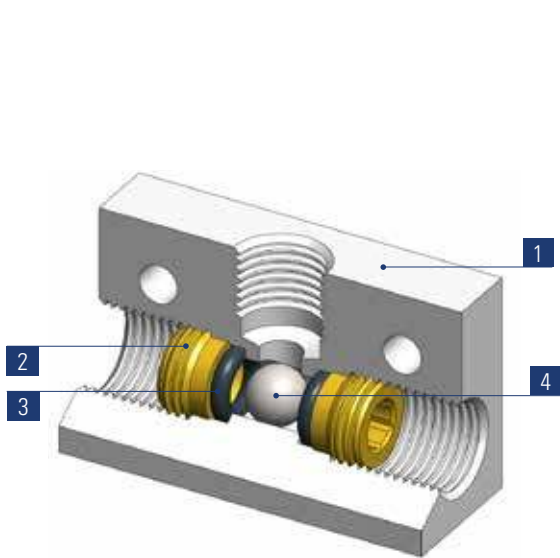

Tipo	D1	D2	L1	L2	L3	S	g Δ
32 00 18	G1/8	4,5	25	50	32	15	46
32 00 14	G1/4	5,5	30	52	35	25	76

Vengono utilizzate in un impianto quando due valvole indipendenti l'una dall'altra devono comandare la stessa apparecchiatura. Il segnale, da qualsiasi delle due valvole pervenga, viene ricevuto dalla valvola selettiva ed inviato all'elemento da comandare.

It is used when two valves have to operate the same equipment. The signal, no matter from which of the two valves it comes, is received by the shuttle valve and transmitted to the device to operate.

Il est utilisé dans les installations pneumatiques lorsque deux vannes doivent commander un seul équipement. Dans le cas où deux signaux sont transmis simultanément, seulement un signal sera pris en compte par le sélecteur et transmis à l'équipement à piloter.

Diese Ventile werden in einer pneumatischen Anlage eingesetzt, wenn zwei Ventile unabhängig voneinander das gleiche Gerät steuern müssen. Das Signal, egal von welchem der zwei Ventile es kommt, wird von dem Oderventil empfangen und zu dem Gerät gesendet, das anzusteuern ist.

SPECIFICHE TECNICHE

Tubi di collegamento consigliati:
variabili in funzione del tipo di raccordo collegato alla valvola.

DATA SHEET

Recommended tubings:
according to the fitting connected to the valve.

REINSEIGNEMENTS TECHNIQUES

Tube conseillé:
en fonction du raccord monté sur la vanne.

TECHNISCHE AUSKUNFTE

Empfohlene Schläuche:
Die Schläuche werden durch die am Schnelllüftungsventil montierte Verschraubung bestimmt.

Campi di applicazione:
impianti pneumatici alimentati con aria filtrata e lubrificata.

Application field:
pneumatic installations fed with filtered, lubricated air.

Domaines d'application:
circuits pneumatiques avec air filtré et lubrifié.

Anwendungsbereiche:
pneumatische Anlage mit gefilterter und geölter Druckluft.

1	2	3
Raccordo Automatico Push-in fittings Raccords instantanés Steckverschraubungen	Bussola Cartridge Cartouche Patrone	Guarnizioni Seals Joint d'étanchéité Dichtung
Raccordo Automatico serie MA MA line push-in fittings Raccords instantanés série MA MA Steckverschraubungen	Ottone UNI EN 12164 CW614N Nichelato Brass UNI EN 12164 CW614N Nickel plated Laiton UNI EN 12164 CW614N Nickelé Messing UNI EN 12164 CW614N vernickelt	NBR NBR NBR NBR



P = 6 bar - Δp = 1 bar



FIGURA 1



Tipo	Øe Tubo	D1	D2	D3	D4	L1	L2	L3	CH	g ΔΔ
44 04 M5	4	M5x0,8	9	10	...	4	11	18	3	12
44 04 18	4	G1/8	9	14,5	...	5	18	19	13	17
44 06 M5	6	M5x0,8	12	10	...	4	11	20,5	3	14
44 06 18	6	G1/8	12	14,5	...	5	18	21,5	13	20
44 06 14	6	G1/4	12	16	...	6,5	21,5	21,5	13	23,5
44 08 18	8	G1/8	14	14,5	...	5	18	22	13	23
44 08 14	8	G1/4	14	16	...	6,5	21,5	22	13	26,5

Nota:

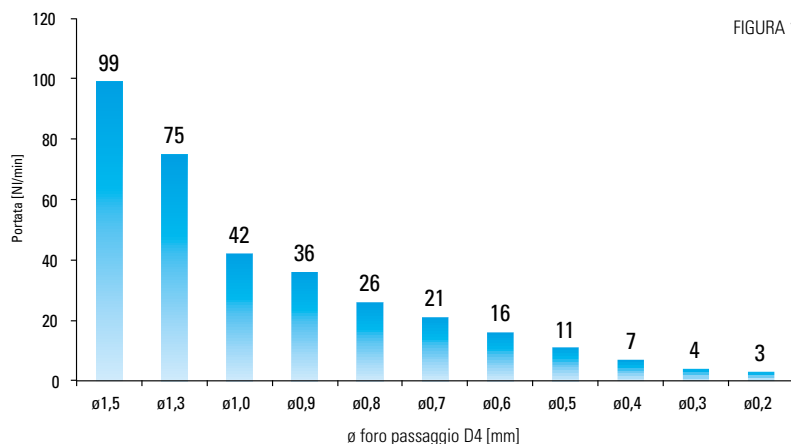
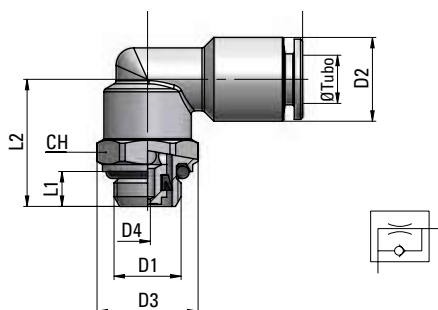
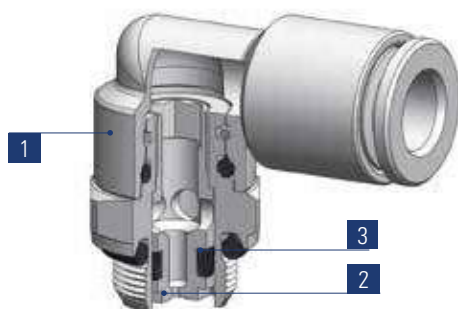
In fase d'ordine specificare dopo il codice dell'articolo d'interesse il diametro del foro calibrato (D4) che si desidera es. (MV 44 06 18 0,3)

In case of order, please state after the part number, the size of the calibrated orifice (D4) i.e (MV 44 06 18 0,3)

En cas de commande, veuillez s'il Vous plaît indiquer après la référence, le diamètre du trou calibré (D4) désiré. (Ex. MV 44 06 18 0,3)

Im Auftragsfall, nach der Referenznummer bitte immer den Durchmesser der kalibrierten Bohrung (D4) angeben. (Beispiel MV 44 06 18 0,3)

Questi raccordi hanno al loro interno una bussola con un foro calibrato il cui diametro determina uno strozzamento del flusso che potrà così assumere i valori riportati in Fig. 1. Tipico impiego degli strozzatori sono quelle applicazioni dove si conosce a priori il flusso o la velocità desiderata dei cilindri e dove non siano richieste regolazioni successive. I vantaggi derivanti dall'impiego degli strozzatori consistono nell'impossibilità di apportare regolazioni indesiderate al flusso e nella costanza nel tempo della regolazione, cosa fondamentale in presenza di vibrazioni.

This fitting houses a cartridge with a calibrated orifice. The orifice diameter causes a flow throttling thereby allowing the desired flow (see our Chart 1).

The throttle fittings are mostly used when the user knows the exact cylinder speed and when no further settings of the cylinder are requested.

The major advantage is that no undesired tamperings can occur and in case of vibrations the flow setting will remain stable.

Ces raccords ont à l'intérieur une cartouche à trou calibré, dont le diamètre produit un étranglement du débit. Par cela on pourra atteindre les débits indiqués dans notre tableau 1. Ces étrangleurs sont bien utilisés surtout dans les applications où l'on connaît déjà a priori le débit désiré ou la vitesse des verins, qui après ne pourront être modifiés que en changeant la cartouche. Les avantages principaux de ces étrangleurs sont l'impossibilité de changer le réglage du débit et la constance dans le temps du réglage, ce qui est particulièrement important en présence de vibrations.

Diese Verschraubung enthält eine Patrone mit kalibrierter Bohrung, deren Durchmesser eine Durchflußdrosselung bewirkt. Dadurch werden die nachstehenden Durchflußwerte erreicht. Diese Drosselverschraubungen finden in jene Anlagen Anwendung, wo der Durchfluß oder die Zylindergeschwindigkeit im voraus bekannt ist und vorwiegend, wo weitere Einstellungen nicht mehr nötig sind. Der Vorteil dieser Verschraubung liegt darin, dass es nicht möglich ist unerwünscht den Durchfluss einzustellen und vor allem, dass die Einstellung konstant in der Zeit trotz möglichen Vibrationen bleibt.

SPECIFICHE TECNICHE

Tubi di collegamento consigliati:
PA11, PA12, PA6, Poliuretano PU (98 Shore A)

Campi di applicazione:
impianti pneumatici alimentati con aria filtrata e lubrificata.

DATA SHEET

Recommended tubings:
PA11, PA12, PA6, Polyurethane PU (98 Shore A)

Application field:
pneumatic installations fed with filtered, lubricated air.

REINSEIGNEMENTS TECHNIQUES

Tube conseillé:
PA11, PA12, PA6, Polyurethane PU (98 Shore A).

Domaines d'application:
circuits pneumatiques avec air filtré et lubrifié.

TECHNISCHE AUSKÜNFTE

Empfohlene Schläuche:
PA11, PA12, PA6, Polyurethan PU (98 Shore A).

Anwendungsbereiche:
pneumatische Anlage mit gefilterter und geölter Druckluft.

MV 45	Valvola di blocco	Pilot Operated Check Valve	Vanne d'arrêt	Sperrventil
1	2	3	4	5
Corpo Body Corps Körper	Pistone Piston Piston Kolben	Molla Spring Ressort Feder	Guarnizioni Seals Joint d'étanchéité Dichtung	Rondelle Gasket Bague Plastique Kunststoffring
Ottone UNI EN 12164 CW614N Nichelato Brass UNI EN 12164 CW614N Nickel plated Laiton UNI EN 12164 CW614N Nickelé Messing UNI EN 12164 CW614N vernickelt	Acciaio Inox AISI 304 Stainless Steel AISI 304 Acier Inox AISI 304 Edelstahl AISI 304	Acciaio Inox AISI 302 Stainless Steel AISI 302 Acier Inox AISI 302 Edelstahl AISI 302	NBR-PU NBR-PU NBR-PU NBR-PU	PA6 PA6 PA6 PA6

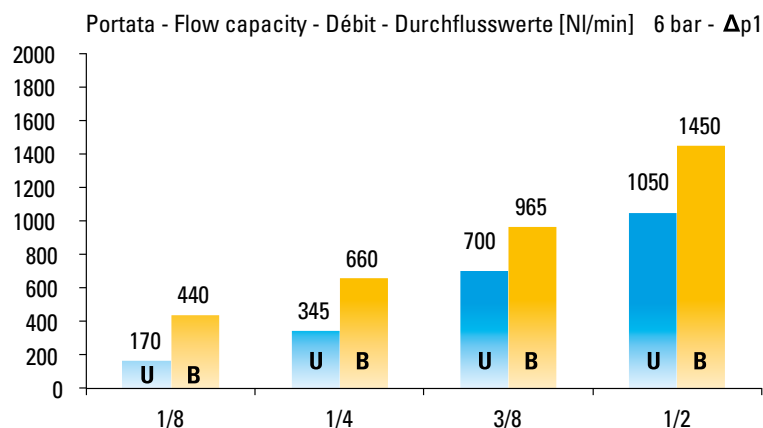
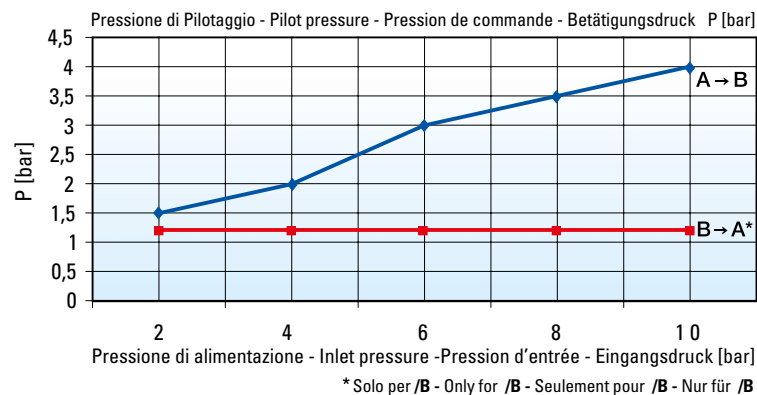
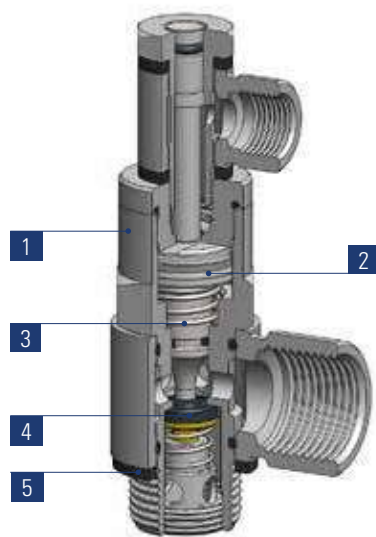

Le valvole di blocco pilotate, se montate in coppia su un cilindro, in caso di una diminuzione improvvisa della pressione di comando, assicurano che ogni movimento del cilindro venga impedito. Mediante il dispositivo di sblocco, è possibile ripristinare manualmente la corsa del pistone, cosa particolarmente utile in fase di messa a punto oppure in mancanza d'aria.

SPECIFICHE TECNICHE

Tubi di collegamento consigliati:
Variabili in funzione del tipo di raccordo collegato alla valvola.

Campi di applicazione:
impianti pneumatici alimentati con aria filtrata e lubrificata.

Should a sudden pressure failure happen, if the stop valves are assembled in pairs on the cylinder, the stop valves make sure, that the cylinder piston rapidly stops. By operating the override device, it is possible to reset manually the piston stroke, which is particularly important during a set-up phase or in case of air shortage.

DATA SHEET

Recommended tubings:
according to the fitting connected to the valve.

Application field:
pneumatic installations fed with filtered, lubricated air.

La vanne d'arrêt pilotée permet, si montée en couple sur un vérin, de bloquer instantanément le déplacement de la tige du vérin en cas de chute brutale de la pression. Une commande manuelle permet de réalimenter le vérin. Cette fonctionnalité est particulièrement intéressante pendant la mise au point d'une machine ou en cas de problème sur l'alimentation d'air.

REINSEIGNEMENTS TECHNIQUES

Tube conseillé:
En fonction du raccord monté sur la vanne.

Domaines d'application:
circuits pneumatiques avec air filtré et lubrifié.

Wenn zwei Sperrventile am Zylinderanschluss montiert werden, bei plötzlichem Druckabfall halten sie den Zylinderkolben schlagartig an. Mittels der Handbetätigung kann man den Kolbenhub noch laufen lassen, was bei einer Einrichtungsphase oder aber bei Luftausfall besonders vorteilhaft ist.

TECHNISCHE AUSKÜNFTE

Empfohlene Schläuche:
Die Schläuche werden durch die am Schnellentlüftungsventil montierte Verschraubung bestimmt.

Anwendungsbereiche:
pneumatische Anlage mit gefilterter und geölter Druckluft.

/U = Valvola Unidirezionale - One Way - Unidirectionel - Einseitig

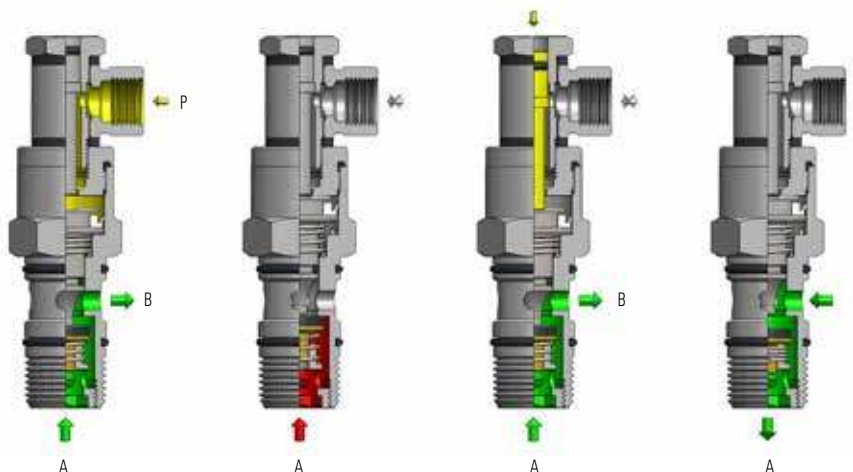
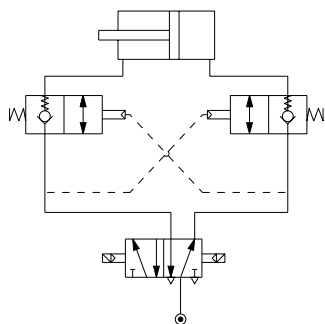

/B = Valvola Bidirezionale - Bidirectional - Bidirectionel - Beidseitig

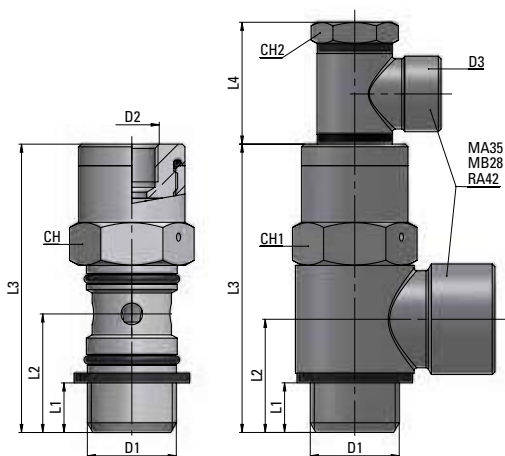
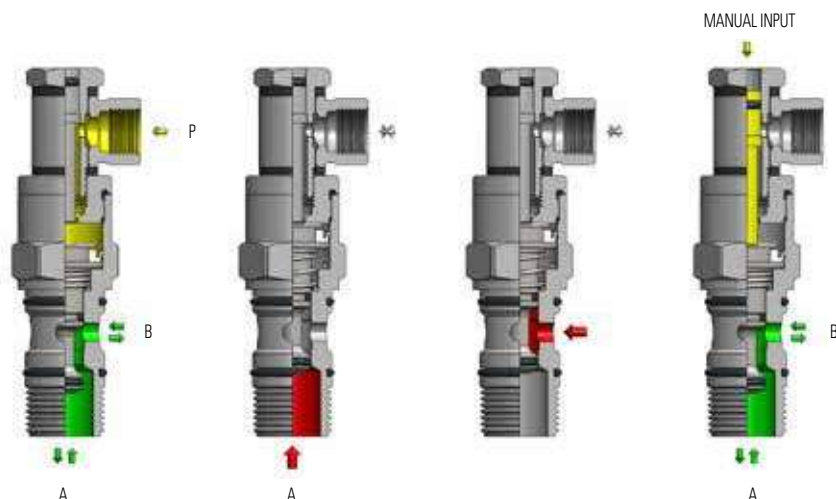
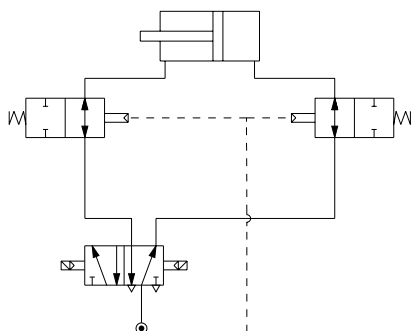

Tipo	D1	D2	D3	L1	L2	L3	L4	CH1	CH2	g Δ
45 00 18	G1/8	M5x0,8	\varnothing 4-M5x0,8	6	15,5	42	20	13	8	24
45 00 14	G1/4	M5x0,8	\varnothing 4-M5x0,8	8	18,5	47	20	17	8	47
45 00 38	G3/8	G1/8	\varnothing 6-G1/8	9	21	53,5	23	20	14	78
45 00 12	G1/2	G1/8	\varnothing 6-G1/8	10	24,5	60	23	25	14	139

Disponibile nelle versioni:

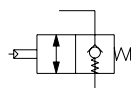

.../U

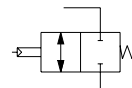

.../B

MV 46		Interruttore pneumatico	Pneumatic switch	Vanne à levier basculant	Kipphebelventil
1	2	3	4	5	
Corpo Body Corps Körper	Leva Handle Levier Hebel	Guarnizioni Seals Joint d'étanchéité Dichtung	Molla Spring Ressort Feder	Rondelle Gasket Bague Plastique Kunststoffring	
Ottone UNI EN 12164 CW614N Nichelato Brass UNI EN 12164 CW614N Nickel plated Laiton UNI EN 12164 CW614N Nickelé Messing UNI EN 12164 CW614N vernickelt		NBR NBR NBR NBR	Acciaio Inox AISI 302 Stainless Steel AISI 302 Acier Inox AISI 302 Edelstahl AISI 302	PA6 PA6 PA6 PA6	

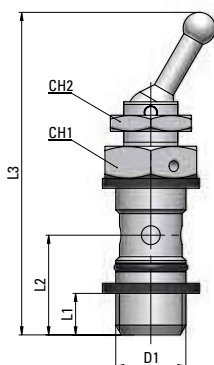
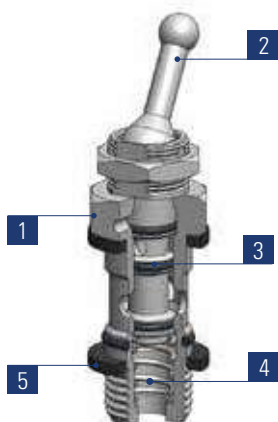
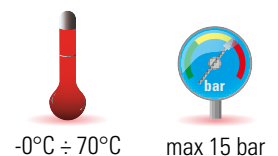

2/2



3/2



Portata
Flow rate
Débit
Druckfluß

	(6 bar - Δp = 1bar)
1/8	235 NI/min
1/4	265 NI/min

Tipo	D1	L1	L2	L3	CH1	CH2	g Δ
46 00 18	G1/8	6	16	55	14	15	25
46 00 14	G1/4	8	19	60	17	15	41

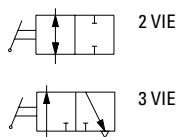

Queste valvole hanno la funzione di sezionare un circuito (ON/OFF) semplicemente azionando la leva di comando; disponibili nelle versioni a 2 vie e a 3 vie, con l'impiego della valvola a 3 vie, oltre al sezionamento del circuito a valle dell'interruttore si ottiene anche lo scarico dello stesso in atmosfera.

The MV 46 is a pneumatic switch. It is available in a 2/2 and 3/2-way version. The goal of the 2/2 way switch is to cut off the flow in the circuit whenever needed by simply operating the lever. The 3/2 way valve cuts off the flow and vents to atmosphere the terminal part of the circuit.

Notre MV 46 est une vanne à levier basculant. Elle est disponible en deux versions: 2/2 et 3/2 voies. La vanne à 2 voies permet d'interrompre le débit dans un circuit pneumatique par un simple mouvement du levier de la vanne. Avec la version à 3 voies on n'achève pas seulement l'interruption du débit, mais on permet aussi l'échappement en atmosphère de la partie à val du circuit.

Unser MV 46 ist in zwei Ausführungen verfügbar und zwar als 2/2 oder als 3/2 Wege-Kipphebelventil. Das 2 Wege-Kipphebelventil dient vorwiegend dazu, die Druckluft in einer Anlage mit einer einfachen Handbewegung des Hebels auszuschalten. Das 3/2 Wege-Kipphebelventil ermöglicht die Ausschaltungsfunktion der Druckluft und dazu auch die Entlüftung in die Atmosphäre vom Teil der Anlage, der sich nach dem Ventil befindet.

SPECIFICHE TECNICHE

Tubi di collegamento consigliati:
variabili in funzione del tipo di raccordo collegato alla valvola.

Campi di applicazione:
impianti pneumatici alimentati con aria filtrata e lubrificata.

DATA SHEET

Recommended tubings:
according to the fitting connected to the valve.

Application field:
pneumatic installations fed with filtered, lubricated air.

REINSEIGNEMENTS TECHNIQUES

Tube conseillé:
en fonction du raccord monté sur la vanne.

Domaines d'application:
circuits pneumatiques avec air filtré et lubrifié.

TECHNISCHE AUSKÜNFTE

Empfohlene Schläuche:
Die Schläuche werden durch die am Schnellentlüftungsventil montierte Verschraubung bestimmt.

Anwendungsbereiche:
pneumatische Anlage mit gefilterter und geölter Druckluft.

Interruttore pneumatico
in linea

In-Line Pneumatic switch

Vanne à levier basculant
en ligne

Kipphebelventil, in Linie

MV 48

1	2	3	4	5
Corpo Body Corps Körper	Interruttore Pneumatic switch Interrupteur pneumatique Kipphebelventil	Molla Spring Ressort Feder	Guarnizioni Seals Joint d'étanchéité Dichtung	Raccordo Automatico Push-in fittings Raccords instantanés Steckverschraubungen
POM POM POM POM	Ottone UNI EN 12164 CW614N Nichelato Brass UNI EN 12164 CW614N Nickel plated Laiton UNI EN 12164 CW614N Nickelé Messing UNI EN 12164 CW614N vernickelt	Acciaio Inox AISI 302 Stainless Steel AISI 302 Acier Inox AISI 302 Edelstahl AISI 302	NBR NBR NBR NBR	Raccordo Automatico serie MB MB line push-in fittings Raccords instantanés série MB MB Steckverschraubungen

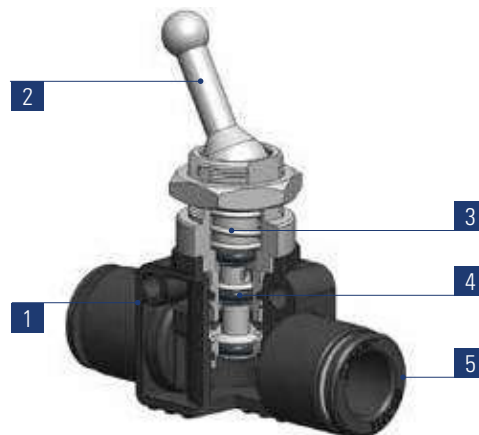

Portata
Flow rate
Débit
Druckfluß

(6 bar - Δp = 1bar)

Ø6	185 NI/min
Ø8	190 NI/min

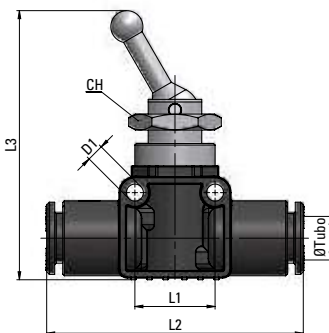

Tipo	Øe Tubo	D1	L1	L2	L3	CH	g Δ
48 06 06	6	3,2	16	45	49	15	30
48 08 08	8	3,2	16	46	50	15	31,5

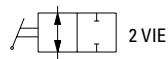

Queste valvole hanno la funzione di sezionare un circuito (ON/OFF) semplicemente azionando la leva di comando; disponibili nelle versioni a 2 vie e a 3 vie, con l'impiego della valvola a 3 vie, oltre al sezionamento del circuito a valle dell'interruttore si ottiene anche lo scarico dello stesso in atmosfera

The MV 48 is a pneumatic switch. It is available in a 2/2 and 3/2-way version. The goal of the 2/2 way switch is to cut off the flow in the circuit whenever needed by simply operating the lever.
The 3/2 way valve cuts off the flow and vents the terminal part of the circuit.

Notre MV 48 est une vanne à levier basculant. Elle est disponible en deux versions: 2/2 et 3/2 voies. La vanne à 2 voies permet d'interrompre le débit dans un circuit pneumatique par un simple mouvement du levier de la vanne. Avec la version à 3 voies on n'achève pas seulement l'interruption du débit, mais on permet aussi l'échappement en atmosphère de la partie à val du circuit.

Unser MV 48 ist in zwei Ausführungen verfügbar und zwar als 2/2 oder als 3/2 Wege-Kipphebelventil. Das 2 Wege-Kipphebelventil dient vorwiegend dazu, die Druckluft in einer Anlage mit einer einfachen Handbewegung des Hebels auszuschalten. Das 3/2 Wege-Kipphebelventil ermöglicht die Ausschaltungsfunktion der Druckluft und dazu auch die Entlüftung in die Atmosphäre vom Teil der Anlage, der sich nach dem Ventil befindet.

SPECIFICHE TECNICHE

Tubi di collegamento consigliati:
PA11, PA12, PA6, Poliuretano PU (98 Shore A)

Campi di applicazione:
impianti pneumatici alimentati con aria filtrata e lubrificata.

DATA SHEET

Recommended tubings:
PA11, PA12, PA6, Polyurethane PU (98 Shore A).

Application field:
pneumatic installations fed with filtered, lubricated air.

REINSEIGNEMENTS TECHNIQUES

Tube conseillé:
PA11, PA12, PA6, Polyurethane PU (98 Shore A).

Domaines d'application:
circuits pneumatiques avec air filtré et lubrifié.

TECHNISCHE AUSKÜNFTE

Empfohlene Schläuche:
PA11, PA12, PA6, Polyurethan PU (98 Shore A).

Anwendungsbereiche:
pneumatische Anlage mit gefilterter und geölter Druckluft.

MV 47	Economizzatore Regolatore di pressione	Pressure control	Réducteur de pression	Druckregler
1	2	3		
Corpo Body Corps Körper	Molla Spring Ressort Feder	Guarnizioni Seals Joint d'étanchéité Dichtung		
Ottone UNI EN 12164 CW614N Nichelato Brass UNI EN 12164 CW614N Nickel plated Laiton UNI EN 12164 CW614N Nickelé Messing UNI EN 12164 CW614N vernickelt	Acciaio Inox AISI 302 Stainless Steel AISI 302 Acier Inox AISI 302 Edelstahl AISI 302	NBR NBR NBR NBR		

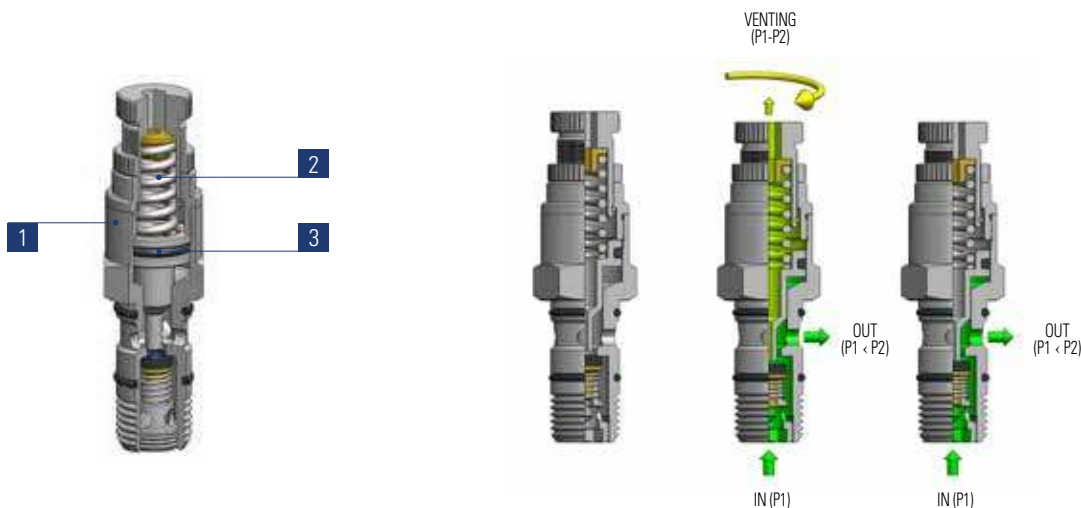
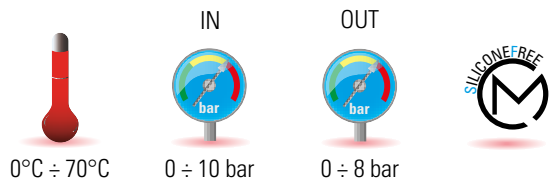

Portata
Flow rate
Débit
Druckfluß

(6 bar - Δp = 1bar)

1/8	205 NI/min
1/4	290 NI/min

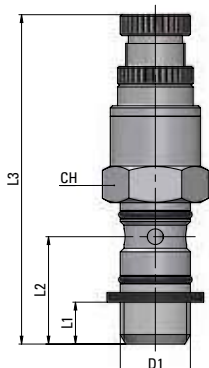

Tipo	D1	L1	L2	L3 max	CH	g Δ
47 00 18	G1/8	6	15,5	56	15	33
47 00 14	G1/4	8	18,5	63	17	55

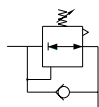

Installati in un circuito pneumatico permettono di regolare la pressione di lavoro delle attrezzature collegate, mantenendo tale regolazione costante nel tempo. Particolarmente interessante è l'applicazione come Economizzatore, che si ottiene collegando il regolatore tra la valvola ed il cilindro da comandare. In questo modo è possibile ottenere una riduzione di pressione e di velocità dello stelo in un unico senso (quello desiderato), contenendo così il consumo d'aria da parte del cilindro.

SPECIFICHE TECNICHE

Tubi di collegamento consigliati:
variabili in funzione del tipo di raccordo collegato al regolatore.

Campi di applicazione:
impianti pneumatici alimentati con aria filtrata e lubrificata.

When installed in a pneumatic circuit, the pressure control sets the working pressure of all the connected components. The pressure adjustment will be thereby kept steady for a long time. It can also be used as an economizer when connected between the valve and the cylinder to operate. Pressure is being saved and rod speed decreased in the desired direction. A big energy saving is this way obtained.

DATA SHEET

Recommended tubings:
according to the fitting connected to the pressure control.

Application field:
pneumatic installations fed with filtered, lubricated air.

Le réducteur de pression permet de régler la pression de travail des équipements et de la maintenir constante. Le réducteur peut aussi jouer le rôle d' "économisateur", lorsqu'il est utilisé entre la vanne et le vérin. Grâce à cette solution, on réduit la pression et la vitesse du vérin dans le sens désiré et on optimise l'énergie employée.

REINSEIGNEMENTS TECHNIQUES

Tube conseillé:
en fonction du raccord monté sur la vanne.

Domaines d'application:
circuits pneumatiques avec air filtré et lubrifié.

Der Druckregler wird überwiegend in pneumatischen Anlagen eingesetzt und regelt den Betriebsdruck einzelner Geräte. Er gewährleistet den eingestellten Druck auf Dauer. Empfehlenswert ist die Verwendung als Energiesparventil. In diesem Fall wird der Druckregler zwischen dem Ventil und dem zu betätigenden Zylinder eingesetzt. Dadurch wird der Druck herabgesetzt und der Zylinderkolben in der beliebigen Richtung verlangsamt. Eine grosse Energieersparnis wird durch den Einsatz dieses Gerätes erreicht.

TECHNISCHE AUSKÜNFTE

Empfohlene Schläuche:
Die Schläuche werden durch die am Drosselrückschlagventil.

Anwendungsbereiche:
pneumatische Anlage mit gefilterter und geölter Druckluft.

1	2	3	4	5	6
Corpo Body Corps Körper	Spillo Needle Epingle Nadel	Molla Spring Ressort Feder	Guarnizioni Seals Joint d'étanchéité Dichtung	Anello Banjo Ring Banjo Ringstück	Rondelle Gasket Bague Plastique Kunststoffring
Ottone UNI EN 12164 CW614N Nichelato Brass UNI EN 12164 CW614N Nickel plated Laiton UNI EN 12164 CW614N Nickelé Ms Vernickelt UNI EN 12164 CW614N		Acciaio Inox AISI 302 Stainless Steel AISI 302 Acier Inox AISI 302 Edelstahl AISI 302	NBR-PU NBR-PU NBR-PU NBR-PU	Ottone UNI EN 12165 CW617N Nichelato Brass UNI EN 12165 CW617N Nickel plated Laiton UNI EN 12165 CW617N Nickelé Ms Vernickelt UNI EN 12165 CW617N	PA6 PA6 PA6 PA6

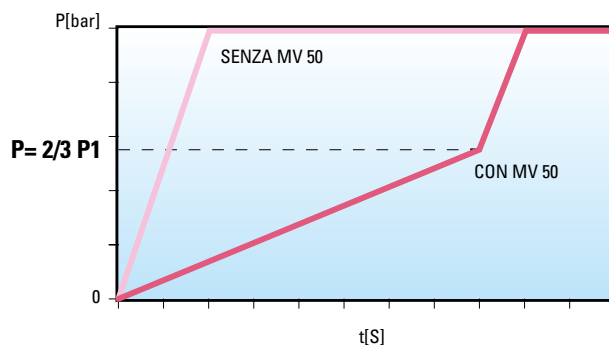
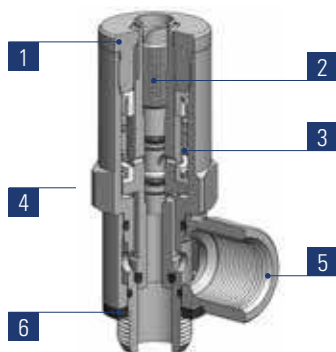
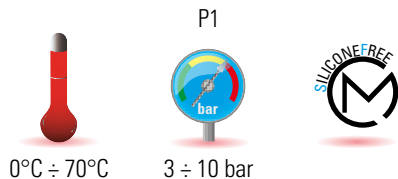

Portata
Flow rate
Débit
Druckfluß

	(6 bar - Δp = 1bar)
MV50 1/4	1040 NI/min
MV50 3/8	1900 NI/min
MV50 1/2	2570 NI/min

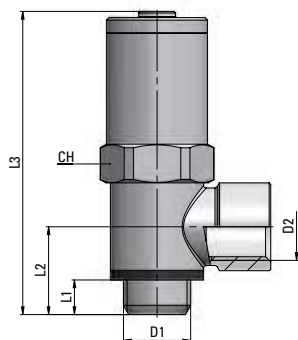

Tipo	D1	D2	L1	L2	L3	CH	g ΔΔ
50 00 14	G1/4	G1/4	6,5	17	66	20	99
50 00 38	G3/8	G3/8	9	21	71,5	20	128
50 00 12	G1/2	G1/2	10	24,5	74,5	25	185

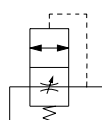

Questo raccordo a funzione consente di mandare in pressione gradualmente l'impianto evitando agli attuatori eventualmente presenti nella linea i cosiddetti "colpi d'ariete" provocati da una pressurizzazione immediata dell'impianto precedentemente scaricato. L'avviatore progressivo aprendosi lentamente nel modo preimpostato dall'utente tramite apposita vite di regolazione immette progressivamente la pressione nel circuito consentendo agli attuatori di raggiungere la posizione di lavoro gradualmente senza subire bruschi colpi. La velocità di riempimento del circuito è determinata dalla rotazione dello spillo di regolazione: ruotandolo in senso orario si avrà un riempimento sempre più lento.

This fitting allows for a progressive pressurization of the installation and prevents the actuators from being hit hard in case of sudden pressure feeding of the previously vented circuit. Depending on the desired spindle setting, the Slow Start Fitting will open gradually, pressure will progressively flow into the circuit and the actuators will go back to their working position without being hit. Pressure feeding speed is indeed determined by the rotation of the spindle. If turned clockwise, a very smooth pressurization will be achieved.

Ce raccord permet de pressuriser l'installation progressivement sans que les actuateurs subissent de coups brusques entraînés par une pressurisation immédiate du circuit précédemment évacué. En fonction du réglage de la vis choisi par l'utilisateur, la vanne s'ouvre lentement et, par conséquent, la pressurisation à l'intérieur du circuit se fait graduellement. La vitesse de remplissage du circuit est déterminée par la rotation de la vis de réglage. Plus on la fait tourner dans le sens des aiguilles d'une montre et plus le remplissage est lent.

Dieses Ventil ermöglicht einen progressiven Druckaufbau in der Anlage und vermeidet, dass die Aktuatoren bei sofortiger Druckzuführung in die vorab entlüftete Anlage harten und plötzlichen Schlägen ausgesetzt werden. Das progressive Anfahrventil macht sich je nach Spindeleinstellung langsam auf, lässt Luftdruck durch und gewährleistet, dass die Anlagenaktuatoren ohne plötzliche Schläge die Arbeitsstelle erreichen. Die Geschwindigkeit des Druckaufbaus wird von der Einstellungsspindel bestimmt. Dreht man sie im Uhrzeigersinn, erfolgt die Füllung immer langsamer.

SPECIFICHE TECNICHE

Tubi di collegamento consigliati:
variabili in funzione del tipo di raccordo collegato alla valvola.

Campi di applicazione:
impianti pneumatici alimentati con aria filtrata e lubrificata.

DATA SHEET

Recommended tubings:
according to the fitting connected to the valve.

Application field:
pneumatic installations fed with filtered, lubricated air.

REINSEIGNEMENTS TECHNIQUES

Tube conseillé:
en fonction du raccord monté sur la vanne.

Domaines d'application:
circuits pneumatiques avec air filtré et lubrifié.

TECHNISCHE AUSKÜNFTE

Empfohlene Schläuche:
Die Schläuche werden durch die am Schnellentlüftungsventil montierte Verschraubung bestimmt.

Anwendungsbereiche:
pneumatische Anlage mit gefilterter und geölter Druckluft.

MV 52	Finecorsa pneumatico	Threshold sensor	Fin de course pneumatique	Endlagenmelder
1	2	3		
Corpo Body Corps Körper	Guarnizioni Seals Joint d'étanchéité Dichtung	Raccordo Automatico Push-in fittings Raccords instantanés Steckverschraubungen		
Ottone UNI EN 12164 CW614N Nichelato Brass UNI EN 12164 CW614N Nickel plated Laiton UNI EN 12164 CW614N Nickelé Ms Vernickelt UNI EN 12164 CW614N	NBR-PU NBR-PU NBR-PU NBR-PU	Raccordo Automatico serie MA MA line push-in fittings Raccords instantanés série MA MA Steckverschraubungen		

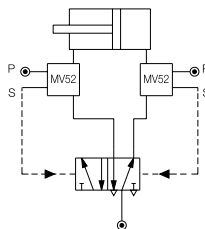

3	0,3	
4	0,5	
5	0,65	Pressione di commutazione (bar)
6	0,9	Switching pressure (bar)
7	1	Pression de commutation (bar)
8	1,2	Umstellungsdruck (bar)
9	1,4	
10	1,6	

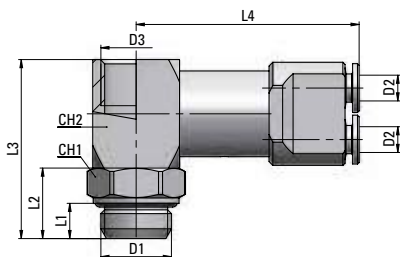
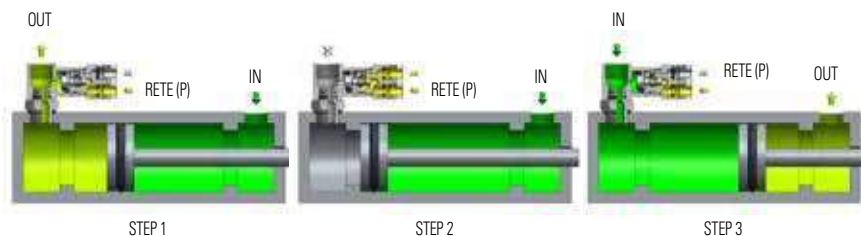
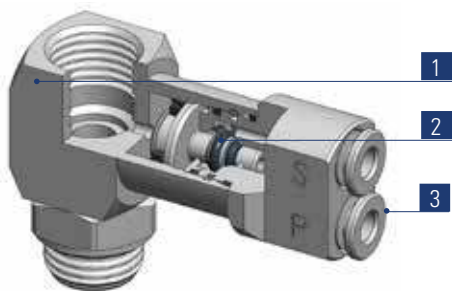

Tipo	D1	D2	D3	L1	L2	L3	L4	CH1	CH2	g
52 00 18	G1/8	4	G1/8	5	11	29,5	38	13	16	69
52 00 14	G1/4	4	G1/4	6,5	13	33	40	16	16	79
52 00 38	G3/8	4	G3/8	7	13	33	42	20	20	98

Questo raccordo a funzione è in grado di rilevare una caduta di pressione emettendo, al suo verificarsi un segnale di comando (S). Particolarmente interessante è l'applicazione di questo raccordo come "Sensore di finecorsa" ottenuta montando direttamente sul cilindro il raccordo sensore: al raggiungimento della corsa completa del cilindro (annullamento della contropressione di scarico nella camera del cilindro) si ha l'emissione di un segnale di pilotaggio per la valvola direzionale che commutandosi invierà al cilindro il comando per l'inversione della corsa. Il principale vantaggio ottenuto impiegando questi raccordi funzione è la possibilità di poter comandare la corsa del cilindro senza necessità di cablaggi elettrici; l'unica condizione imposta per il corretto funzionamento del sensore pneumatico è che il cilindro deve fare la corsa completa, non sono ammesse posizioni intermedie.

SPECIFICHE TECNICHE

Tubi di collegamento consigliati:
variabili in funzione del tipo di raccordo collegato alla valvola.

Campi di applicazione:
impianti pneumatici alimentati con aria filtrata e lubrificata.

Threshold sensor can detect a pressure drop and signal it with a command signal (S). This component turns out to be especially useful when assembled directly on the cylinder. When the piston completes its stroke (no more counter pressure available in the cylinder), a command signal is given out to a direction valve to have the piston change the stroke. Sole condition required for perfect component performance is that the piston has to complete its stroke. No intermediate positions are allowed. Major advantage of this component is to command the piston stroke changes without electrical connections

DATA SHEET

Recommended tubings:
according to the fitting connected to the valve.

Application field:
pneumatic installations fed with filtered, lubricated air.

Le but de ce raccord à fonction est de signaler une chute de pression par l'intermédiaire d'un signal de commande (S). L'emploi le plus intéressant de ce produit, est le montage directement sur le vérin: à l'achèvement de la course du piston (plus contre-pression dans la chambre du vérin), il envoi un signal à la vanne direction, pour qu'elle commande le changement de la course du piston. La condition principale pour un fonctionnement parfait du fin de course est que le piston doit avoir terminé sa course. Les positions intermédiaires ne sont pas permises. L'avantage principal de ce composant consiste à commander la course du piston sans électricité.

REINSEIGNEMENTS TECHNIQUES

Tube conseillé:
en fonction du raccord monté sur la vanne.

Domaine d'application:
circuits pneumatiques avec air filtré et lubrifié.

Bei Druckausfall weist diese Funktionsverschraubung durch einen Steuersignal darauf hin (S). Besonderes Interesse erweckt der Einsatz der Endlagenmelder direkt am Zylinder, so dass bei komplettem Kolbenhub (nach Abfallen des Gegendruck in der entlüftenden Zylinderkammer) ein Steuersignal an Steuerventil ausgegeben wird, welches zum Beispiel die Richtungsänderung des Zylinders auslöst. Das Steuersignal kann aber für viele andere Steuerungsaufgaben eingesetzt werden. Das Ventil findet überall dort seinen Einsatz wo ein pneumatisches Ausgangssignal nach Druckabbau der entlüftenden Zylinderkolbenkammer gefordert wird. Der Hauptvorteil des Einsatzes der Signalverschraubung ist die Signalverarbeitung ohne elektrische Verbindung.

TECHNISCHE AUSKÜNFTE

Empfohlene Schläuche:
Die Schläuche werden durch die am Schnellentlüftungsventil montierte Verschraubung bestimmt.

Anwendungsbereiche:
pneumatische Anlage mit gefilterter und geölter Druckluft.

1	2	3	4	5
Corpo Body Corps Körper	Otturatore Valve Clapet Ventil	Molla Spring Ressort Feder	Guarnizioni Seals Joint d'étanchéité Dichtung	Raccordo Automatico Push-in fittings Raccords instantanés Steckverschraubungen
Ottone UNI EN 12164 CW614N Nichelato Brass UNI EN 12164 CW614N Nickel plated Laiton UNI EN 12164 CW614N Nickelé Ms Vernickelt UNI EN 12164 CW614N		Acciaio Inox AISI 302 Stainless Steel AISI 302 Acier Inox AISI 302 Edelstahl AISI 302	NBR NBR NBR NBR	Raccordo Automatico serie MA MA line push-in fittings Raccords instantanés série MA MA Steckverschraubungen

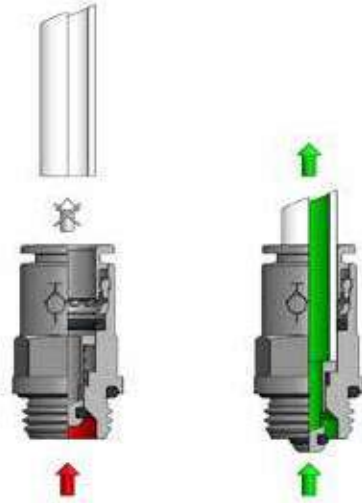
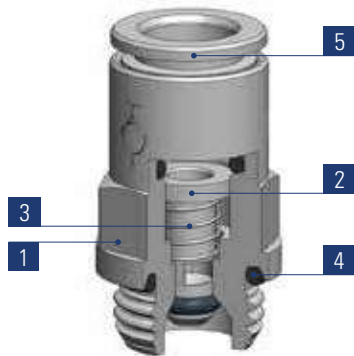

Portata Flow rate Débit Druckfluß	(6 bar - Δp = 1 bar)
1/8	365 NI/min
1/4	380 NI/min

Tipo	D1	D2	D3	L1	L2	CH	g ΔΔ
55 06 18	G1/8	6	13,5	5	27	12	15
55 06 14	G1/4	6	16	6,5	27	12	18
55 08 18	G1/8	8	13,5	5	27,5	13	18
55 08 14	G1/4	8	16	6,5	27,5	13	21

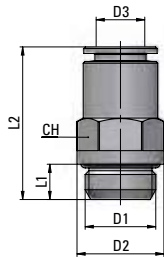

Questo raccordo è dotato di un otturatore che si sblocca solo a seguito dell'inserimento del tubo nel raccordo permettendo così il passaggio dell'aria solo con il tubo inserito. Se per qualche motivo il tubo dovesse sganciarsi il flusso d'aria proveniente dal raccordo verrebbe arrestato dalla chiusura dell'otturatore.

This fitting is provided with a check valve that opens when inserting the tubing into the fitting. Only then the air flow is allowed. Should the tube accidentally get released, the valve would immediately close again and the air flow would stop.

Ce raccord est pourvu à l'intérieure d'une vanne d'arrêt qui s'ouvre et permet le passage d'air seulement au moment de l'insertion du tube. Dans le cas d'un décrochage du tube accidentel, la vanne se ferme et le passage d'air en est bloqué.

Diese Verschraubung ist mit einem internen Sperrventil versehen, das sich nur bei Einstecken des Schlauches aufmacht. Erst dadurch wird der Durchfluss ermöglicht. Sollte versehentlich der Schlauch gelöst werden, wird sich das Sperrventil zumachen und automatisch den Durchfluss sperren.

SPECIFICHE TECNICHE

Tubi di collegamento consigliati:
PA11, PA12, PA6, Poliuretano PU (98 Shore A).

Campi di applicazione:
impianti pneumatici alimentati con aria filtrata e lubrificata.

DATA SHEET

Recommended tubings:
PA11, PA12, PA6, Polyurethane PU (98 Shore A)

Application field:
pneumatic installations fed with filtered, lubricated air.

REINSEIGNEMENTS TECHNIQUES

Tube conseillé:
PA11, PA12, PA6, Polyurethane PU (98 Shore A)

Domaine d'application:
circuits pneumatiques avec air filtré et lubrifié.

TECHNISCHE AUSKÜNFTE

Empfohlene Schläuche:
PA11, PA12, PA6, Polyurethan PU (98 Shore A).



Anwendungsbereiche:
pneumatische Anlage mit gefilterter und geölter Druckluft.

Silenziatori

Air mufflers

Silencieux

Schalldämpfer

	Corpo Body Corps Körper	Silenziatore Muffler Silencieux Schalldämpfer	Guarnizioni Seals Joint d'étanchéité Dichtung		
MV11-FE	Ottone UNI EN 12164 CW614N Nichelato Brass UNI EN 12164 CW614N Nickel plated Laiton UNI EN 12164 CW614N Nickelé Ms Vernickelt UNI EN 12164 CW614N	Acciaio Inox AISI 304 Stainless Steel AISI 304 Acier Inox AISI 304 Edelstahl AISI 304		0 ÷ 12 bar	-10 ÷ 70 °C
MV11-FEP	PA6	Acciaio Inox AISI 304 Stainless Steel AISI 304 Acier Inox AISI 304 Edelstahl AISI 304		0 ÷ 12 bar	-10 ÷ 70 °C
MV11-PL	POM			0 ÷ 6 bar	-10 ÷ 70 °C
MV11-CO - MV11-CQ MV11-BE - MV11-VE MV11-P	Ottone UNI EN 12164 CW614N Brass UNI EN 12164 CW614N Laiton UNI EN 12164 CW614N Ms UNI EN 12164 CW614N	Bronzo Sinterizzato Sintered bronze Bronze fritté Sinterbronze		0 ÷ 12 bar	-10 ÷ 70 °C
MV14	Ottone UNI EN 12164 CW614N Nichelato Brass UNI EN 12164 CW614N Nickel plated Laiton UNI EN 12164 CW614N Nickelé Ms Vernickelt UNI EN 12164 CW614N	Bronzo Sinterizzato Sintered bronze Bronze fritté Sinterbronze	NBR NBR NBR NBR	0 ÷ 10 bar	-10 ÷ 70 °C

Livello di rumore a 6 bar - Noise level at 6 bar
Niveau de bruit à 6 bar - Geräuschstand bei 6 bar

Tipo	1/8	1/4	3/8	1/2
MV11 -FE	74 dB	72 dB	88 dB	90 dB
MV11 -FEP	74 dB	72 dB	88 dB	90 dB
MV11 -CO	70 dB	67 dB	77 dB	80 dB
MV11 -CQ	70 dB	67 dB	77 dB	80 dB
MV11 -BE	75 dB	81 dB	82 dB	85 dB
MV11 -P	72 dB	73 dB	84 dB	88 dB
MV11 -PL	87 dB	84 dB	90 dB	90 dB
MV11 -VE	72 dB	73 dB	84 dB	88 dB

Soglia di filtrazione - Filtration threshold
Seuil de Filtration - Filterungsschwelle

Tipo	
MV11 -FE	100-200 µm
MV11 -FEP	100-200 µm
MV11 -CO	35 µm
MV11 -CQ	35 µm
MV11 -BE	35 µm
MV11 -P	80 µm
MV11 -PL	-
MV11 -VE	80 µm

MV 11-FE

Silenziatore in ottone con filo in acciaio inox

Air muffler with stainless steel wire

Silencieux avec fil acier inox

Schalldämpfer mit Edelstahl Draht

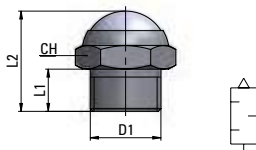

Tipo	D1	L1	L2	CH	g $\Delta\Delta$
11 00 18-FE	G1/8	6	15	13	6
11 00 14-FE	G1/4	7	18	16	10
11 00 38-FE	G3/8	8	20	19	16
11 00 12-FE	G1/2	10	22	24	25

MV 11-FEP

Silenziatore con filo in acciaio inox

Air muffler with stainless steel wire

Silencieux avec fil acier inox

Schalldämpfer mit Edelstahl Draht

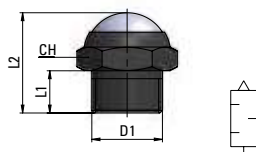

Tipo	D1	L1	L2	CH	g $\Delta\Delta$
11 00 18-FEP	G1/8	6	15	13	1,5
11 00 14-FEP	G1/4	7	18	16	3
11 00 38-FEP	G3/8	8	20	19	4
11 00 12-FEP	G1/2	10	22	24	7

MV 11-CO

Silenziatore in bronzo sinterizzato

Sintered bronze air muffler

Silencieux en bronze fritté

Schalldämpfer aus Sinterbronze

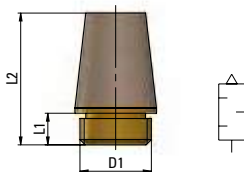

Tipo	D1	L1	L2	g $\Delta\Delta$
11 00 M5-CO	M5x0,8	4,5	13	1,5
11 00 18-CO	G1/8	6	21	8
11 00 14-CO	G1/4	6	25	16
11 00 38-CO	G3/8	8	36	22
11 00 12-CO	G1/2	10	43	49

MV 11-CQ

Silenziatore in bronzo sinterizzato

Sintered bronze air muffler

Silencieux en bronze fritté

Schalldämpfer aus Sinterbronze

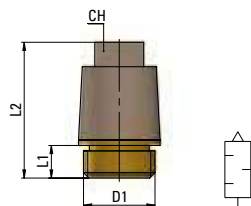

Tipo	D1	L1	L2	CH	g $\Delta\Delta$
11 00 18-CQ	G1/8	6	21	7	8
11 00 14-CQ	G1/4	6	25	8	14
11 00 38-CQ	G3/8	8	38	10	32
11 00 12-CQ	G1/2	10	43	14	62

MV 11-BE

Silenziatore in bronzo sinterizzato

Sintered bronze air muffler

Silencieux en bronze fritté

Schalldämpfer aus Sinterbronze

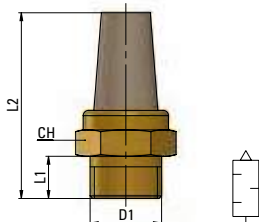

Tipo	D1	L1	L2	CH	g $\Delta\Delta$
11 00 M5-BE	M5x0,8	4	17	8	2,5
11 00 18-BE	G1/8	6	29	13	9
11 00 14-BE	G1/4	7	32	16	16
11 00 38-BE	G3/8	8	40	19	25
11 00 12-BE	G1/2	9	45	24	47

MV 11-P

Silenziatore a pastiglia

Flat muffler

Silencieux, plat

Schalldämpfer aus Sinterbronze, flache Ausführung

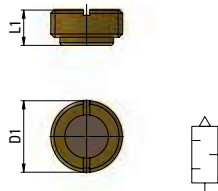

Tipo	D1	L1	g $\Delta\Delta$
11 00 18-P	G1/8	5	1,5
11 00 14-P	G1/4	6	3,5
11 00 38-P	G3/8	7	6
11 00 12-P	G1/2	8	11

MV 11-PL

Silenziatore a sfere di plastica

Plastic ball muffler

Silencieux à boules plastique

Schalldämpfer mit Kunststoffkugeln

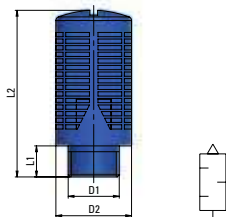

Tipo	D1	D2	L1	L2	g $\Delta\Delta$
11 00 18-PL	G1/8	15	6	32,5	4,5
11 00 14-PL	G1/4	19,5	8	43	9
11 00 38-PL	G3/8	24,5	11	58	14
11 00 12-PL	G1/2	24,5	11	58	18

MV 11-VE

Regolatore di scarico con silenziatore in bronzo sinterizzato

Exhaust Control with sintered bronze air muffler

Réducteur d'échappement avec silencieux en bronze fritté

Entlüftungsdrosselventil mit Schalldämpfer aus Sinterbronze

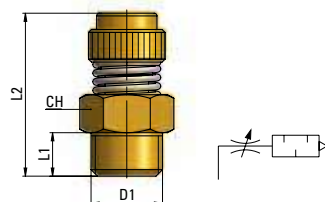

Tipo	D1	L1	L2 max	CH	g $\Delta\Delta$
11 00 18-VE	G1/8	6	28	13	16
11 00 14-VE	G1/4	8	32	15	24
11 00 38-VE	G3/8	10	38	22	53
11 00 12-VE	G1/2	11	40	22	59

MV 14

Regolatore di scarico con silenziatore

Exhausting Control with muffler

Réducteur d'échappement avec silencieux

Entlüftungsdrosselventil mit Schalldämpfer

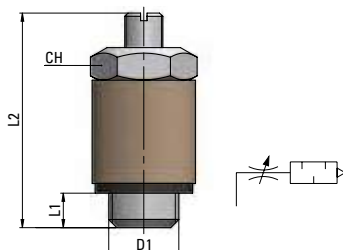

Tipo	D1	L1	L2 max	CH	g $\Delta\Delta$
14 00 M5	M5x0,8	4	25	8	6
14 00 18	G1/8	5	32	14	28
14 00 14	G1/4	6,5	40	17	52
14 00 38	G3/8	7	50	20	90

Valvole a sfera

Ball Valves

Vannes à sphère

Kugelhähne

	1	2	3	4	5	6	7
MV24 - MV25	Corpo Body Corps Körper	Bussola Cartridge Cartouche Patrone	Sfera Ball Bille Kugel	Asta Stem Tige Spindel	Oring sede sfera Ball seat oring Joints d'étanchéité du logement billes Dichtungen des Kugelgehäuses	Guarnizioni Seals Joint d'étanchéité Dichtung	Leva Handle Manette Griff
	Ottone UNI EN 12165 CW617N Cromato Brass UNI EN 12165 CW617N Chrome plated Laiton UNI EN 12165 CW617N chromé Ms Verchromt UNI EN 12165 CW617N	Ottone UNI EN 12164 CW614N Nichelato Brass UNI EN 12164 CW614N Nickel plated Laiton UNI EN 12164 CW614N Nickelé Ms Vernickelt UNI EN 12164 CW614N			P.T.F.E P.T.F.E P.T.F.E P.T.F.E	NBR NBR NBR NBR	ABS ABS ABS ABS
MV53 - MV54	Corpo Body Corps Körper	Sfera Ball Bille Kugel		Asta Stem Tige Spindel	Oring sede sfera Ball seat oring Joints d'étanchéité du logement billes Dichtungen des Kugelgehäuses	Guarnizioni Seals Joint d'étanchéité Dichtung	Leva Handle Manette Griff
	Ottone UNI EN 12164 CW614N UNI EN 12165 CW617N Cromato Brass UNI EN 12164 CW614N UNI EN 12165 CW617N Chrome plated Laiton UNI EN 12164 CW614N UNI EN 12165 CW617N chromé Ms Verchromt UNI EN 12164 CW614N UNI EN 12165 CW617N	Ottone UNI EN 12164 CW614N Nichelato Brass UNI EN 12164 CW614N Nickel plated Laiton UNI EN 12164 CW614N Nickelé Ms Vernickelt UNI EN 12164 CW614N			P.T.F.E P.T.F.E P.T.F.E P.T.F.E	NBR NBR NBR NBR	PA66 PA66 PA66 PA66



-20°C ÷ 90°C



0 ÷ 10 bar

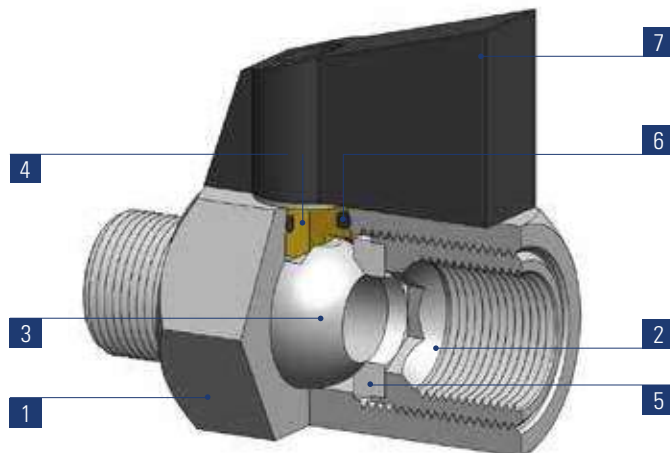

Campi di applicazione:
Impianti pneumatici, idraulici ed oleodinamici.

Application fields:
Pneumatic, hydraulic and oleodynamic circuits.

Domaines d'application:
Circuits pneumatiques, hydrauliques et oléodynamiques.

Anwendungsbereiche:
Hydraulische, öldynamische und pneumatische Anlagen.

MV 24

Rubinetto a sfera F-F

Ball Valve, female

Vanne à sphère, femelle

Kugelhahn mit Innengewinde

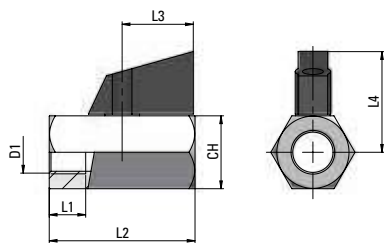

Tipo	D1	L1	L2	L3	L4	CH	g Δ
24 00 18	G1/8	8	39	20,5	29	20	107
24 00 14	G1/4	10	39	20,5	29	20	97
24 00 38	G3/8	10	42	20,5	29	20	86
24 00 12	G1/2	10,5	47	20,5	31	24	128

MV 25

Rubinetto a sfera M-F

Ball Valve, male

Vanne à sphère, mâle

Einschraub - Kugelhahn

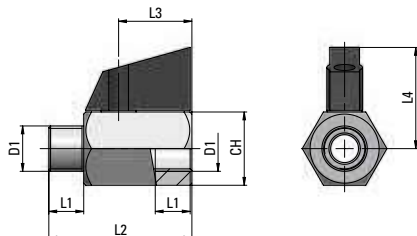

Tipo	D1	L1	L2	L3	L4	CH	g Δ
25 00 18	G1/8	8	39	20,5	29	20	86
25 00 14	G1/4	10	39	20,5	29	20	82
25 00 38	G3/8	10	42	20,5	29	20	79
25 00 12	G1/2	10,5	47	20,5	31	24	120

MV 53

Rubinetto a sfera F-F

Ball Valve, female

Vanne à sphère, femelle

Kugelhahn mit Innengewinde

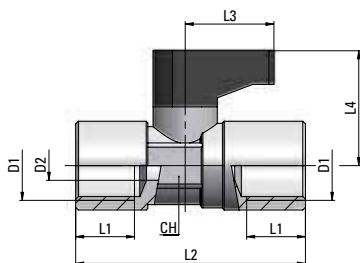

Tipo	D1	D2	L1	L2	L3	L4	CH	g Δ
53 00 18	G1/8	5,5	8	36,5	19	21,5	14	36,6
53 00 14	G1/4	5,5	11	43	19	21,5	14	49
53 00 38	G3/8	8	10,5	43	24	24	17	56
53 00 12	G1/2	10	12	49	34	27	21	93,2

MV 54

Rubinetto a sfera M conico-F

Ball valve, taper Male-Female

Vanne à boules mâle conique-femelle

Kugelhahn kegelig Einschraub-Aufschraub

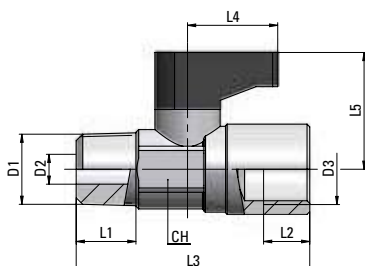

Tipo	D1	D2	D3	L1	L2	L3	L4	L5	CH	g Δ
54 00 18	R1/8	5,5	G1/8	8	8	35,5	19	21,5	14	34,4
54 00 14	R1/4	5,5	G1/4	11	11	40,5	19	21,5	14	42,7
54 00 38	R3/8	8	G3/8	11,5	10,5	43	24	24	17	53
54 00 12	R1/2	10	G1/2	15	12	50	34	27	21	89,5

MV 51	Manometro in linea	Pressure gauge fitting	Raccord à manomètre	Manometerverschraubung
1	2	3	4	
Corpo Body Corps Körper	Filetto Thread Filetage Gewinde	Manometro Gauge Manomètre Manometer		Raccordo Automatico Push-in fittings Raccords instantanés Steckverschraubungen
POM POM POM POM	Ottone UNI EN 12164 CW614N Nichelato Brass UNI EN 12164 CW614N Nickel plated Laiton UNI EN 12164 CW614N Nickelé Ms Vernickelt UNI EN 12164 CW614N	ABS ABS ABS ABS		Raccordo Automatico serie MB MB line push-in fittings Raccords instantanés série MB MB Steckverschraubungen



Versione con attacchi rapidi
Push-in version
Version instantanée
Steckausführung

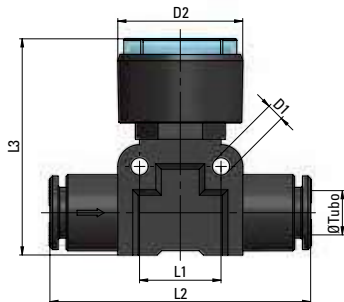

Versione con attacco rapido e filetto
Push-in/threaded version
Version fileté et instantanée
Steck- Einschraubausführung

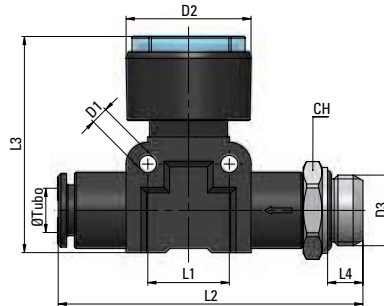

Tipo	Øe Tubo	D1	D2	D3	L1	L2	L3	L4	CH	g Δ
51 06 06	6	3,2	23	-	15	45	38	-	-	15
51 06 18	6	3,2	23	G1/8	15	52	38	5	13	21
51 06 14	6	3,2	23	G1/4	15	54	38	6,5	16	23
51 08 08	8	3,2	23	-	15	46	39,5	-	-	16
51 08 18	8	3,2	23	G1/8	15	53	39,5	5	14	23
51 08 14	8	3,2	23	G1/4	15	55	39,5	6,5	16	25

SPECIFICHE TECNICHE

Tubi di collegamento consigliati:
PA11, PA12, PA6, Poliuretano PU
(98 Shore A)

Precisione:
4

Campi di applicazione:
impianti pneumatici alimentati con aria
filtrata e lubrificata.

DATA SHEET

Recommended tubings:
PA11, PA12, PA6, Polyurethane PU
(98 Shore A)

Accuracy:
4

Application field:
pneumatic installations fed with filtered,
lubricated air.

REINSEIGNEMENTS TECHNIQUES

Tube conseillé:
PA11, PA12, PA6, Polyurethane PU
(98 Shore A).

Précision:
4

Domaine d'application:
circuits pneumatiques avec air filtré
et lubrifié.

TECHNISCHE AUSKÜNFTE

Empfohlene Schläuche:
PA11, PA12, PA6, Polyurethan PU
(98 Shore A).

Genauigkeit:
4

Anwendungsbereiche:
pneumatische Anlage mit gefilterter und
geölter Druckluft.